



JCB FASTRAC | 3190/3220



**ABS
BRAKING**

FULLY SUSPENDED WITH 4 WHEEL ABS DISC BRAKING.
JCB SMOOTHSHIFT TRANSMISSION.

STATIC DIMENSIONS

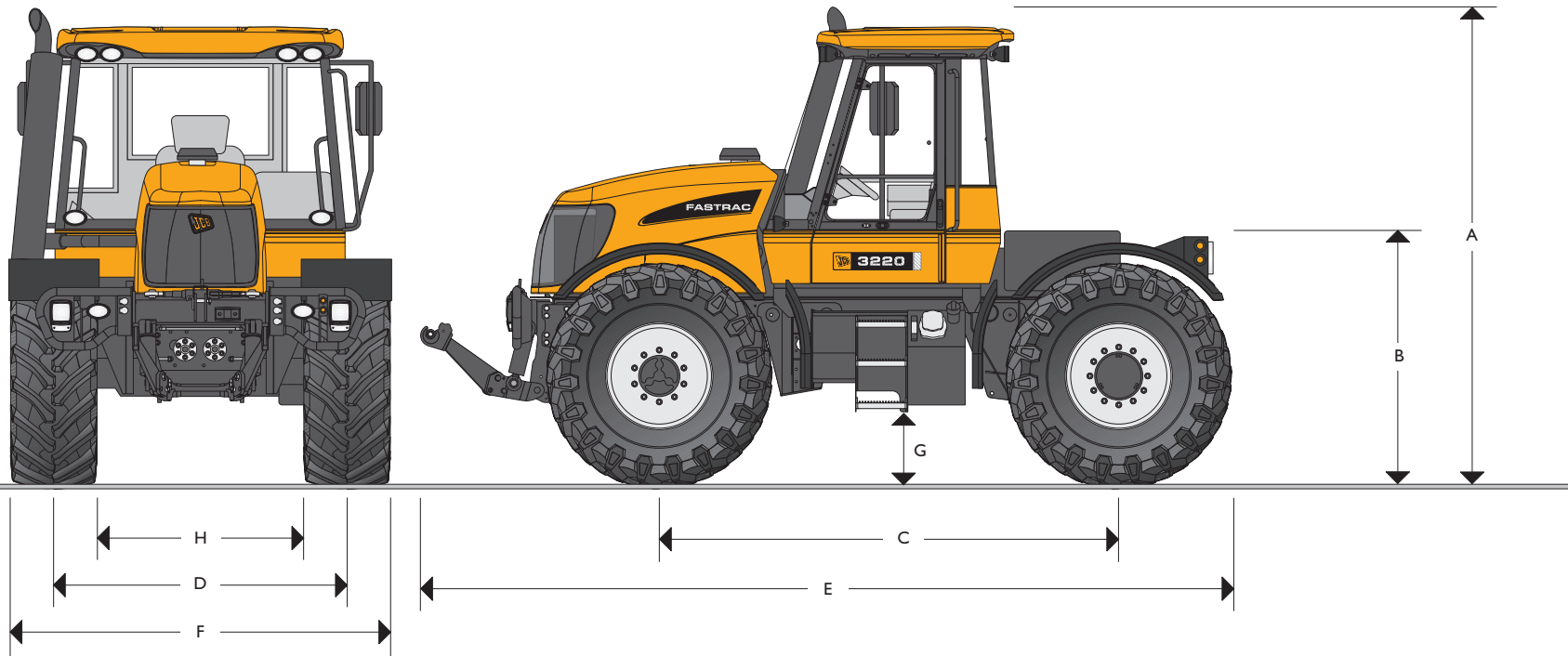

STATIC DIMENSIONS

Tyres	520/70R30	495/70R24
	m (ft-in)	m (ft-in)
A Height to exhaust	3.15 (10-4)	3.07 (10-1)
B Height to deck	1.55 (5-1)	1.47 (4-10)
C Wheelbase	3.06 (10-0)	3.06 (10-0)
D Track width	2.01 (6-8)	1.87 (6-2)

Tyres	520/70R30	495/70R24
	m (ft-in)	m (ft-in)
E Overall length	5.20 (17-1)	5.20 (17-1)
F Overall width	2.53 (8-4)	2.37 (7-9)
G Ground clearance	0.41 (1-4)	0.33 (1-1)
H Width between tyres	1.49 (4-11)	1.38 (4-6)



JCB FASTRAC | 3190/3220



ENGINE

		3190	3220
Make		Cummins	Cummins
Model		QSB44	QSB44
Rated engine speed	rpm	2300	2300
Gross hp		193	220
DIN hp		178	200
kW		132.7	149.1
Max. torque @ 1500rpm	Nm	750	823
Torque back up		45%	37%
Injection		Direct	Direct
No of cylinders		6	6
Capacity	cc	5883	5883
Bore	mm	102	102
Stroke	mm	120	120
Cooling		Water	
Air cleaner		Dual dry element	
Aspiration		Turbocharged and aircharge cooled	

ELECTRICAL SYSTEM

System voltage	Volt	12
Alternator output	Amp	150
Battery capacity	Amp hour	2 x 105

Electrical wiring – to IP67 standard.

CAPACITIES

	litres (UK gal)
Fuel tank	350 (77)
Hydraulic tank	120 (26.4)

CLUTCH

Smoothshift multi-plate oil immersed. Clutch hydraulically clamped and electronically controlled.

SUSPENSION

Front: Coil spring and damper, microcellular secondary spring.

Rear: Hydro-pneumatic self levelling.

HYDRAULICS

3 point linkage: Electronic draft/position intermix, rate of drop, adjustable lift height, plus external lift and lower.

Rear hitch: 7000kg (15431 lb)*; Category III; Quick attach hook ends, eye end top link.

Front hitch (optional): Lift capacity at link ends – 3500kg; Category II; Folding, quick attach type.

*(Optional 8000kg lift capacity on both models).



AUXILIARY HYDRAULICS

- Max oil flow:** 104 l/min
- Operating pressure:** 210 bar
- Spool valves:**
- Type A – 4 position double acting, with flow control, zero leak and float position.
 - Type B – 4 position double acting with zero leak and float position.
 - Type C – Electronic 4 position double acting with flow control, float position, switchable kick-out and zero leak.
 - Type D – Electronic 4 position double acting with time control, float position, switchable kick-out and zero leak.

N.B. Please note that on machines fitted with electronic spool valves, the green spool valve (Type C) has priority flow.

Auxiliary Hydraulic Package		Standard		Plus	
		3190	3220	3190	3220
1	Type A	●	●	–	–
	Type A 3 spool	●	●	–	–
	Type B	○	○	–	–
2	Type A	○	○	–	–
	Type A 4 spool	○	○	–	–
	Type B (3 to rear)	○	○	–	–
3	Type C	–	–	●	●
	Type C 3 spool	–	–	●	●
	Type D	–	–	○	○
4	Type C	–	–	○	○
	Type C 4 spool	–	–	○	○
	Type D (4 to rear)	–	–	○	○
Type D	Type D	–	–	○	○
	Type D	–	–	○	○

● = Standard ○ = Option – = N/A

- Couplers:** Deluxe Quick release/spill-off piped to reservoir.
- Pipework/hose:** BSP standard.

POWER TAKE OFF

- Type:** Fully independent to front and rear (front optional).
- Actuation:** Electro-hydraulic.
- Speeds:** 540rpm @ 2002 engine rpm
1000rpm @ 2195 engine rpm
- PTO power:** **3190** – 168hp, 125.3kW **3220** – 190hp, 141.7kW
- Speed change:** By in-cab lever, 540: neutral: 1000rpm
Front and rear always rotate at same speed.
- Output spline:** 6 or 21 1³/₈" diameter.

AXLES

- Both axles:**
- Beam type with outboard epicyclic reduction hubs.
 - 10 stud wheel retention on front axle.
 - 12 stud wheel retention on rear axle.
 - Four wheel drive selectable by rotary switch – electro-hydraulic sprung on/pressure off (on the move).
 - Both front and rear differentials electro-hydraulic soft engage clutch type.
 - 2 ABS speed sensors and pole wheels.

STEERING

- Type:** Re-circulating ball, power assist.
- Column:** Tilt and telescope adjustable.
- Turning circle:** Kerb to kerb
- 13.58m on 480/70R30 @ 2015mm (80") track.
 - 14.28m on 520/70R30 @ 2015mm (80") track.
 - 13.28m on 495/70R24 @ 1875mm (74") track.

BRAKES

Type	3190	3220
1	●	–
2	○	●

● = Standard ○ = Option – = N/A

- Type 1:** ABS with single caliper outboard discs on all four wheels.
- Type 2:** ABS with twin caliper outboard discs on all four wheels and heavy duty suspension system.
- Operation:** Air over hydraulic to EEC truck specification.
- Park brake type:** Independent disc on transmission output shaft.
- Actuation:** Sprung on, air pressure off.
- Trailer brakes:**
1. Twin line air brakes.
 2. Single line hydraulic brakes for agricultural use for speeds up to 20mph.
 3. Air trailer brake automatically applied by tractor park brake.
 4. ABS 12v trailer supply socket as standard.

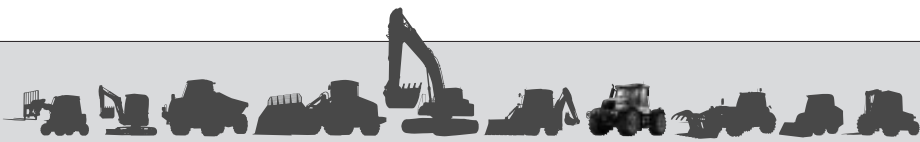

JCB FASTRAC | 3190/3220



TRANSMISSION

54 forward, 18 reverse gears. 6 gear manual synchromesh gearbox. Low, medium, high, reverse synchromesh range box with JCB Smoothshift and Autos Shuttle features. 3 speed JCB Autoshift clutchless splitter with manual and automatic modes. Forward speeds @ rated engine speed (km/hr):

		3190			3220		
		Snail	Tortoise	Hare	Snail	Tortoise	Hare
		km/hr	km/hr	km/hr	km/hr	km/hr	km/hr
High	6	47.5	56.9	68.4	47.5	56.9	68.4
	5	36.5	43.8	52.7	39.2	47.0	56.5
	4	25.4	30.5	36.6	31.5	37.8	45.5
	3	16.9	20.3	24.4	21.0	25.2	30.3
	2	10.8	13.0	15.6	13.4	16.1	19.4
Medium	1	6.3	7.5	9.1	7.8	9.4	11.3
	6	27.2	32.7	39.3	27.2	32.7	39.3
	5	21.0	25.2	30.2	22.5	27.0	32.4
	4	14.6	17.5	21.0	18.1	21.7	26.1
	3	9.7	11.7	14.0	12.1	14.5	17.4
Low	2	6.2	7.4	9.0	7.7	9.2	11.1
	1	3.6	4.3	5.2	4.5	5.4	6.5
	6	9.5	11.4	13.7	9.5	11.4	13.7
	5	7.3	8.8	10.5	7.9	9.4	11.3
	4	5.1	6.1	7.3	6.3	7.6	9.1
Reverse	3	3.4	4.1	4.9	4.2	5.1	6.1
	2	2.2	2.6	3.1	2.7	3.2	3.9
	1	1.3	1.5	1.8	1.6	1.9	2.3
	1	2.2	2.6	3.1	2.7	3.2	3.9
	2	3.7	4.5	5.4	4.6	5.6	6.7
3	5.9	7.0	8.4	7.3	8.7	10.5	
4	8.8	10.5	12.7	10.9	13.1	15.7	
5	12.6	15.2	18.2	13.6	16.3	19.5	
6	16.4	19.7	23.7	16.4	19.7	23.7	

520/70 R30 tyres at Rated speed (2300rpm)

VEHICLE WEIGHTS

Based on 3190 with full fuel and hydraulic tanks, no driver and no ballast.

	Front axle	Rear axle	Total
	kg	kg	kg
Base machine	3784	3493	7277
plus front Linkage & PTO	4193	3551	7744
Plus machine	3902	3601	7503
plus front Linkage & PTO	4315	3655	7970

REAR LOAD PLATFORM

Maximum dimensions: 1.25 x 2.25m

Capacity: 2500kg (5511lb)
3250kg (7165lb) with heavy duty suspension cylinders.

Sprayers: As approved by JCB Landpower up to 2000 litres and 24m booms.

Note: All deck mounted equipment currently fitted to other JCB Fastracs will fit this machine with minimum modification.

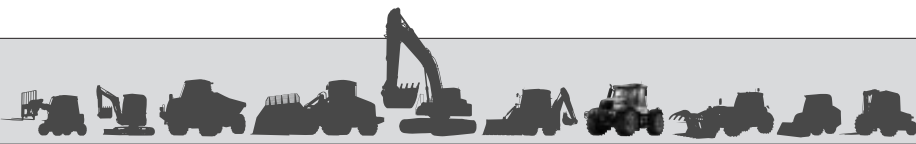

WHEELS AND TYRES

4 equal sized, welded wheels. Rear centres differ to accommodate large reduction hubs. Front directional and rear fixed fenders. Fixed pannier mounted fenders.

Factory fit

	Rate	Track mm (in)	65 km/hr	80 km/hr
495/70R24	G	1875 (74)		●
480/70R30	D/E	1930/2015 (76/80)	●	
520/70R30	D/E	1930/2015 (76/80)	●	
540/65R30	D	1930/2015 (76/80)	●	
480/70R30	D/E	1875 (74)	●	
600/65R28	D/E	1930 (76)	●	

Approved field fit tyres

Operation/Tyre	Typical Track mm (in)
Low ground pressure	
580/70R26	2075 (82)
600/55R26.5	2075 (82)
600/55R30.5	2075 (82)
600/60R30.5	2075 (82)
620/70R26	2075 (82)
700/50R26.5	2075 (82)
750/45R30.5	2075 (82)
750/50R30.5	2075 (82)
800/40R26.5	2075 (82)
54-31 R26	2160 (85)
Row Crop	
13.6 x 38	1830 (72)
11.2 x 44	1830 (72)
9.5 x 44	1830 (72)

Dual wheels are permitted to be fitted to the rear axle only. Tyre load speed rating and axle plated weight must not be exceeded under any circumstances. If in doubt refer to the operators handbook or tyre supplier.

CAB

High specification, 2 door, full width, low noise.

Standard equipment includes:

- Full cab air conditioning.
- Air suspension seat.
- Dust filter and heater.
- Tinted glass.
- Front and rear wash wipe.
- Truck type rear view mirrors.
- Full lighting set including direction indicators, hazard lights, six front and four rear work lights.
- 12v power socket.
- Passenger seat.
- Seat belts.
- Cigar lighter and ashtray.
- Side console illumination.
- Digital clock.
- Beacon.
- Storage compartment.
- Radio preparation.
- Sun blind.
- Cable access through rear window.
- Rear fender mounted PTO cut-out switch.

The above specification may vary according to territory.

PLUS PACKAGE

Plus Package includes: Cable shift gear lever; Electronic spool valves; Electronic front linkage control; Deluxe cab interior.

OPTIONAL EQUIPMENT

- Front hydraulic linkage (Category II) complete with front mounted controls.
- Front PTO, single output.
- Front PTO, bi-directional.
- Four auxiliary spool valves.
- Hydraulic flow divider.
- Front weights.
- Rear deck weight.
- Heavy duty suspension cylinders.
- Front hydraulic service ('T' spool 3).
- Front hydraulic services ('T' spool 3 & 4).
- Front free flow return.
- 20 spline (1.75") PTO stub.
- 6 spline (1.75") PTO stub.
- Radar speed/wheel slip control package.
- Deluxe worklight package.
- Roof hatch.
- Deluxe heated drivers seat.
- Heated windscreen, with heated and electrically adjustable mirrors.



A GLOBAL COMMITMENT TO QUALITY

JCB's total commitment to its products and customers has helped it grow from a one-man business into Britain's largest privately owned manufacturer of backhoe loaders, crawler excavators, wheeled excavators, telescopic handlers, wheeled loaders, dump trucks, rough terrain fork lifts, industrial fork lifts, mini/midi excavators, skid steer loaders and tractors.

By making constant and massive investments in the latest production technology, the JCB factories have become some of the most advanced in Europe.

By leading the field in innovative research and design, extensive testing and stringent quality control, JCB machines have become renowned all over the world for performance, value and reliability.

And with a global sales and service network of over 400 distributors and agents, the company exports over 70% of its production to all five continents.

Through setting the standards by which others are judged, JCB has become one of Britain's most impressive success stories.

