



# JCB FASTRAC | 8250



**ABS  
BRAKING**

FULLY SUSPENDED WITH 4 WHEEL ABS DISC BRAKING.  
JCB V-TRONIC TRANSMISSION.

## STATIC DIMENSIONS

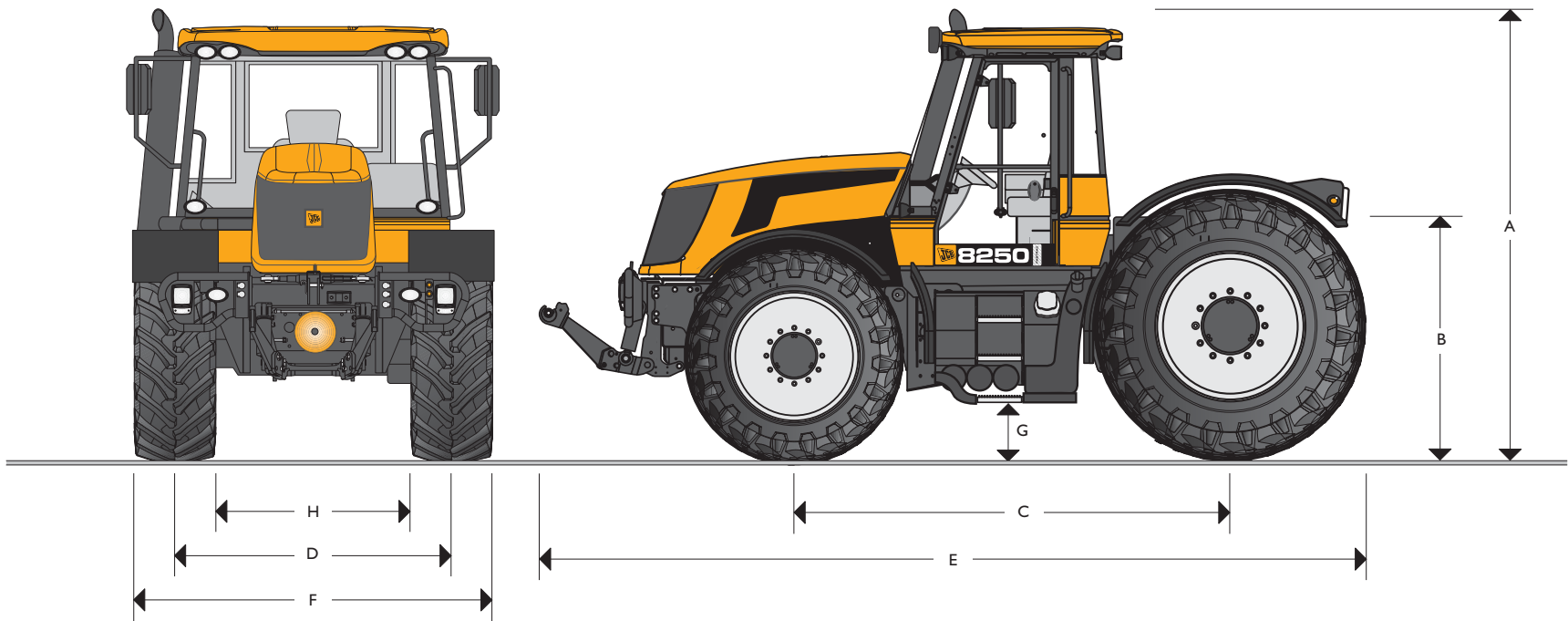

## STATIC DIMENSIONS

Tires	540/65 R38 Front and 710/70 R38 Rear
	ft-in (m)
A Height to exhaust	11-1 (3.39)
B Height to deck	4-11 (1.51)
C Wheelbase	10-3 (3.12)
D Track width (front/rear)	6-8 (2.03) / 6-0 (1.84)

Tires	540/65R38 Front and 710/70 R38 Rear
	ft-in (m)
E Overall length	18-6 (5.65)
F Overall width	8-4 (2.55)
G Ground clearance	1-6 (0.47)
H Width between tires	3-7 (1.10)

JCB FASTRAC | 8250

Helping You Get  
the Job Done!



# JCB FASTRAC | 8250



JCB FASTRAC | 8250

## ENGINE

Make		Cummins
Model		QSC
Rated engine speed	rpm	2200
Max hp at 2000 rpm –SAE J1995	hp/Kw	280 (209)
Max torque @ 1400 rpm	Nm	1179
Torque back up		29%
Injection		CM 850 Common Rail
No of cylinders		6
Capacity	Liters/cu in	8.3 (505)
Bore	mm	114
Stroke	mm	135
Cooling		Water
Air cleaner		Powercore dry element
Aspiration		Turbocharged and intercooled

## SUSPENSION

**Front:** Coil spring and damper, microcellular secondary spring.  
**Rear:** Hydro-pneumatic self leveling.

## ELECTRICAL SYSTEM

System voltage	Volt	12
Alternator output	Amp	150
Battery capacity	Amp hour	2 x 105

Electrical wiring – to IP67 standard.

## CAPACITIES

	gal (liters)
Fuel tank	158 (600)
Hydraulic tank	48 (180)

## HYDRAULICS

**3 point linkage:** Electronic draft/position intermix, rate of drop, adjustable lift height plus external lift and lower.  
**Rear hitch:** 22046lbs Category 3; Quick attach hook ends, eye end top link.  
**Front hitch (optional):** Lift capacity at link ends – 7716lbs, Category 2; Quick attach hook ends, folding arms.).



## JCB FASTRAC | 8250



### AUXILIARY HYDRAULICS

<b>Max oil flow:</b>	55 gal/min
<b>Flow at rated engine speed:</b>	47 gal/min
<b>Operating pressure:</b>	3045 psi
<b>Spool valves:</b>	Electronic 4 position double acting with flow and time control, float position and zero leak.
<b>Standard:</b>	3 spool valves to the rear
<b>Optional:</b>	4 spool valves to the rear. Load sensing hydraulic connection. 1 or 2 front supplies. Front free flow return.
<b>Couplers:</b>	Deluxe Quick release/spill-off piped to reservoir (front and rear).

### POWER TAKE OFF

<b>Type:</b>	Fully independent to front and rear (front optional).
<b>Actuation:</b>	Electro-hydraulic.
<b>Rear PTO speeds Standard:</b>	540rpm @ 1570 engine rpm 1000rpm @ 2030 engine rpm
<b>Rear PTO speeds Option:</b>	540rpm @ 2050 engine rpm 1000rpm @ 2030 engine rpm
<b>Rear PTO output spline:</b>	6 or 21 spline 1 $\frac{3}{8}$ " diameter 6 or 20 spline 1 $\frac{3}{4}$ " diameter (options)
<b>Front PTO speed:</b>	1000rpm @ 2030 engine rpm
<b>Front PTO output spline:</b>	21 1 $\frac{3}{8}$ " diameter or 20 1 $\frac{3}{4}$ " diameter
<b>Max PTO power:</b>	243hp (181kW)
<b>Speed change:</b>	Electro-hydraulic in cab switch. Front PTO only available at 1000rpm.

### AXLES

<b>Type:</b>	Beam with outboard epicyclic reduction hubs.
<b>Wheel mountings:</b>	10 stud front axle 16 stud rear axle
<b>Four wheel drive selection:</b>	On the move engage/disengage using rocker switch.
<b>Differentials:</b>	Front and rear locking with electro-hydraulic soft engagement.

### STEERING

<b>Type:</b>	Re-circulating ball with power assistance and assistor ram.
<b>Column:</b>	Tilt and telescope adjustable.
<b>Turning radius:</b>	22 ft 10 in

### BRAKES

<b>Type:</b>	Outboard discs with twin calipers and ABS on all four wheels.
<b>Operation:</b>	Air over hydraulic to EEC truck specification.
<b>Park brake:</b>	Independent disc on transmission output.
<b>Actuation:</b>	Sprung on, air pressure off.
<b>Trailer brakes:</b>	Twin line air brakes. Single line hydraulic brakes for speeds up to 20mph. (optional) Air trailer brake automatically applied by tractor park brake. ABS 12v trailer supply socket as standard.

JCB FASTRAC | 8250



# JCB FASTRAC | 8250



## TRANSMISSION

**Type:** 2 range continuously variable transmission with 6 modes of operation

**Speeds:** Low Range 0 – 28mph  
High Range 0 – 40mph

Powershift mode		Forward Speed mph/kmh	Reverse Speed mph/kmh
Gear			
High Range	10	42.00 / 67.1	–
	9	40.50 / 65.2	–
	8	35.60 / 57.3	–
	7	28.00 / 45.1	28.00 / 45.1
	6	22.61 / 36.4	22.61 / 36.4
	5	16.78 / 27.0	16.78 / 27.0
	4	13.17 / 21.2	13.17 / 21.2
	3	9.75 / 15.7	9.75 / 15.7
	2	6.70 / 10.8	6.70 / 10.8
	1	4.66 / 7.5	4.66 / 7.5
Low Range	15	26.60 / 42.8	–
	14	21.25 / 34.2	–
	13	16.34 / 26.3	–
	12	13.11 / 21.1	13.11 / 21.1
	11	10.56 / 17.0	10.56 / 17.0
	10	8.45 / 13.6	8.45 / 13.6
	9	6.80 / 11.0	6.8 / 11.0
	8	5.50 / 8.9	5.5 / 8.9
	7	4.29 / 6.9	4.29 / 6.9
	6	3.30 / 5.3	3.30 / 5.3
5	2.73 / 4.4	2.73 / 4.4	
4	2.17 / 3.5	2.17 / 3.5	
3	1.74 / 2.8	1.74 / 2.8	
2	1.25 / 2.0	1.25 / 2.0	
1	0.25 / 0.4	0.25 / 0.4	

540/65 R38 and 710/70 R38 tires at rated engine speed (2200rpm)  
All other modes utilise stepless ratios.

## VEHICLE WEIGHTS

Based on a 8250 with full fuel and hydraulic tanks, no driver and no ballast.

	Front axle	Rear axle	Total
	lb (kg)	lb (kg)	lb (kg)
Machine with front linkage and front PTO	12235 (5550)	11221 (5090)	23457 (10640)

JCB FASTRAC | 8250



## JCB FASTRAC | 8250



### WHEELS AND TIRES

4 welded wheels. Front directional and rear fixed and enclosed fenders. Fixed pannier mounted fenders.  
All tires are speed rated for 65kph

Factory fit	Front tires	Track width in (mm)	Rear tires	Track width in (mm)
Firestone	540/65 R34	78 (1990)	650/65 R38	75 (1900)
Pirelli	540/65 R38	78 (1990)	710/70 R38	72 (1834)

### OPTIONAL EQUIPMENT

Front linkage (Category 2) with electronic control and external raise/lower.  
Front 1000rpm PTO with 21 spline or 20 spline output shaft.  
Four electronic spool valves.  
Load sensing power beyond hydraulic connection  
Front weight.  
Rear deck weight.  
1 or 2 front hydraulic services.  
Front free flow return.  
20 spline 1 3/4" PTO shaft.  
6 spline 1 1/4" PTO shaft.  
Radar and performance monitor.  
Deluxe heated drivers seat.  
Heated front and rear screens with heated and electric mirrors.

### CAB

High specification, 2 door, full width, low noise.

**Standard equipment includes:**

Full heating and air-conditioning.  
Air suspension seat with armrest mounted transmission and auxiliary controls.  
Colour touch screen display, providing transmission information and setup capability.  
Electronic spool valves.  
Full dust filtration.  
Tinted glass.  
Front and rear wash wipe.  
Truck type rear view mirrors.  
Full road lighting equipment with high level brakelight.  
ISO and power supply sockets.  
Full size passenger seat.  
Three point seatbelt for driver and passenger.  
Side console illumination.  
Digital EMS display with clock.  
Storage compartment.  
Radio preparation.  
Sun blind.  
Cable access through rear window.  
Rear fender mounted raise/lower and PTO cut out switches.  
8 front and 6 rear worklights.

JCB FASTRAC | 8250



JCB FASTRAC | 8250



## A GLOBAL COMMITMENT TO QUALITY

JCB's total commitment to its products and customers has helped it grow from a one-man business into the World's 5th largest manufacturer of backhoe loaders, crawler excavators, wheeled excavators, telescopic handlers, wheel loaders, dump trucks, rough terrain fork lifts, industrial fork lifts, mini/midi excavators, skid steer loaders and tractors.

By making constant and massive investments in the latest production technology, the JCB factories have become some of the most advanced in the World.

By leading the field in innovative research and design, extensive testing and stringent quality control, JCB machines have become renowned all over the world for performance, value and reliability.

And with a global sales and service network of over 400 distributors and agents, the company exports over 70% of its production to all five continents.

Through setting the standards by which others are judged, JCB has become one of Britain's most impressive success stories.



801

JCB Headquarters Savannah, 2000 Bamford Blvd., Pooler, GA 31322. Tel: 912.447.2000. Fax: 912.447.2299. [www.jcb.com](http://www.jcb.com)

JCB reserves the right to change design, materials and/or specifications without notice. Specifications are applicable to units sold in the United States and Canada. The JCB logo is a registered trademark of J C Bamford Excavators Ltd.

USA 20114

JCB FASTRAC | 8250

Helping You Get  
the Job Done!