

**PARTS
CATALOG**

ISUZU DIESEL ENGINE

3AE1 TL 2100

3AF1 TL 2100

ENGINE NO. 539934~

生産年月 1979-11~

PART NO. 5-8871-0114-3

3AE1・3AF1型エンジン外観図

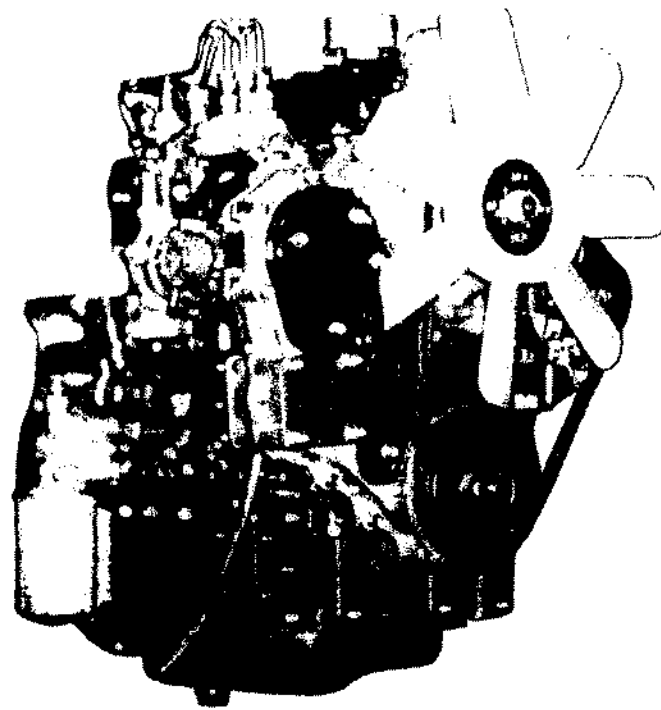

総 目 次
CONTENT

No.	項 目 ITEM	シート索引番号又は付号 INDEX NO. or CODE
1	型式別納入先一覧表 Customers List of Each Type Engine	(A)
2	装置区分目次 (完材品を含む) Group Contents of Equipment (Including Complete Parts)	(B)
3	装置区分イラスト目次 Group Contents of Equipment Illustrated	(C)
4	パーツカタログの使い方 Use of Parts Catalog	(D)
5	略語表 Abbreviations	(E)
6	KIT 又は SET で補給する部品一覧 (補給形態 F) Parts List to be supplied by KIT or SET (Shape Code: F)	(F)
7	パーツカタログ イラストと本文 Parts Catalog Illustrations and Parts List	(1) ~ (80)
8	長尺物形態補給部品一覧 (補給形態 H) Supply List of Long Size Parts (Shape Code: H)	(93)
9	部品名称順索引 (ALPHABETICAL INDEX)	(96)
10	部品番号順索引 (NUMERICAL INDEX)	(97)

(A)

A-1

3AF1, 3AE1, 型式別納入先一覧表

エンジン型式		3AF1					3AE1							
		B B	B L	B L 0 1	B L 0 2	S T D	B 0 1	B 0 2	B B D	S T D	S T D 0 1	E		
年 別 型 式	3AF1, 3AE1, 1980-3~	○	○	○	○	○	○	○	○	○				
	3AF1, 3AE1, 1981-5~	○	○	○	○	○	○	○	○	○		○		
	3AF1, 3AE1, 1982-11~					○				○		○		
	3AF1, 3AE1, 1984-8~										○			
納 入 先	井 関 農 機	○	○	○	○	○	○	○	○	○				
	産 業 用 標 準					○				○				
	イワフジ工業											()		
	石 川 島 建 機										○			
用 途		コン バイン HL2200	農 耕トラ クタTL1900	農 耕トラ クタTU2100	農 耕トラ クタTU1900	農 耕トラ クタTU1700	一 般産 業用	農 耕トラ クタTL2500	農 耕トラ クタTL2300	農 耕トラ クタTL2500	コン バイン HL2500	一 般産 業用	ミニ バック ホー	ミニ バック ホー CT140

CUSTOMERS LISTS OF EACH 3AF1·3AE1 TYPE ENGINE

ENGINE TYPE		3AF1					3AE1							
		B B	B L	B L 0 1	B L 0 2	S T D	B 0 1	B 0 2	B B D	S T D	S T D 0 1	E		
YEARLY TYPE	3AF1, 3AE1 1980-3~	○	○	○	○	○	○	○	○	○				
	3AF1, 3AE1 1980-5~	○	○	○	○	○	○	○	○	○		○		
	3AF1, 3AE1 1982-11~					○				○		○		
	3AF1, 3AE1 1984-8~										○			
CUSTOMERS	ISEKI	○	○	○	○	○	○	○	○	○				
	INDUSTRIAL ENGINE STD					○				○				
	IWAFUJI INDUSTRIAL											○		
	ISHIKAWAJIMA CONSTRUCTION MACHINERY										○			
APPLICATION		Combine HL2200	Farme Tractor TL1900	Farme Tractor TU2100	Farme Tractor TU1900	Farme Tractor TU1700	FOR GENERAL POWER	Farme Tractor TL2500	Farme Tractor TL2300	Farme Tractor TL2100	Combine HL2500	FOR GENERAL POWER	MINI BACK HOE	MINI BACK HOE CT140

目 次
GROUP CONTENTS

B-1

B

イラスト区分 ILLUSTRATION NO.	名 称	NAME
①	CYL. HEAD & OTHER PARTS (HEAD COVER)	
②	CYL. BLOCK & OTHER PARTS	
③	TIMING GEAR CASE & OTHER PARTS	
④	FLY WHEEL HOUSING & OTHER PARTS	
⑤	OIL PAN & OTHER PARTS	
⑥	OIL PUMP & FIXING PARTS	
⑦	CRANK SHAFT, CRANK BRG., PISTON CONN. ROD & FLY WHEEL	
⑧		
⑨	VALVE MECHANISM (CAM SHAFT, IDLE GEAR, ROCKER ARM)	
⑩	OIL FILTER & FUEL FILTER (FIXING PARTS)	
⑪	OIL PIPE & OTHER PARTS	
⑫	COOLING SYSTEM (FAN, WATER & OIL)	
⑬	AIR INTAKE & EXHAUST SYSTEM	
⑭	AIR CLEANER & OTHER PARTS	
⑮	FUEL SYSTEM (INJ. NOZZLE, FUEL PIPE)	
⑯	ENGINE FOOT, HANGER & FIXING PARTS	
⑰		
⑱	INJECTION PUMP & OTHER PARTS	
⑲	ELECTRICAL PARTS	
⑳		
㉑		
㉒		
㉓		
㉔		
㉕		

B

B-2

目次
GROUP CONTENTS

(完材品(補給形態:B)
COMPLETED PARTS(SHAPE CODE : B))

イラスト区分 ILLUSTRATION NO.	名 称	NAME
50		
51		
52	INJECTION PUMP; PROPER	
53		
54	FEED PUMP; INJ. PUMP	
55		
56		
57		
58	NOZZLE HOLDER	
59		
60		
61		
62	STARTER	
63	GENERATOR	
64		
65		
66		
67		
68		
69		
70		
71		
72		
73		
74		
75		
76		
77		
78		
79		
80		

GROUP CONTENTS

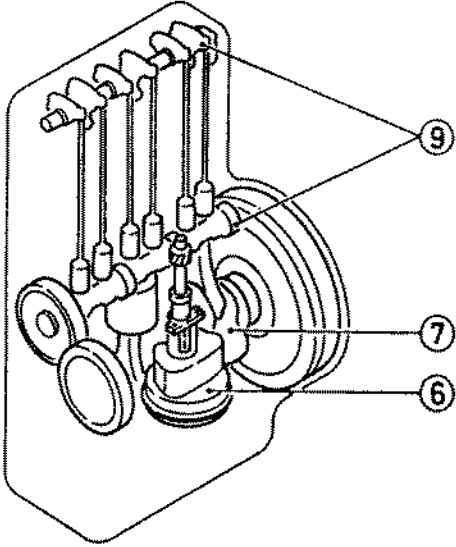
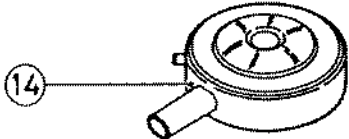
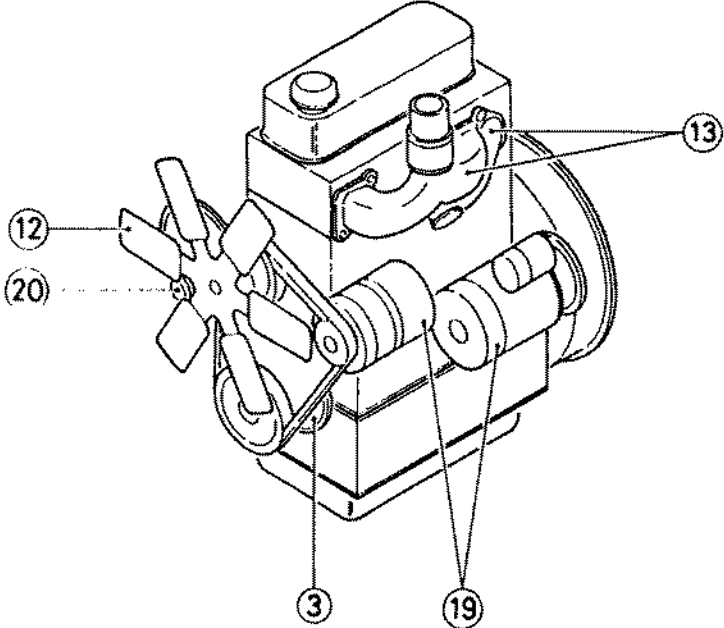
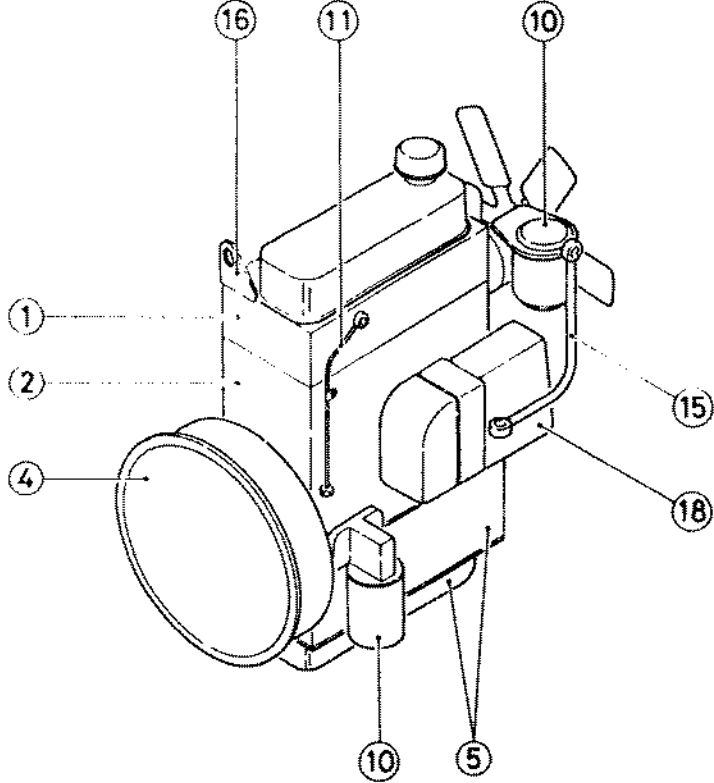

- (単位数) “ A/R ” と記されている場合には、必要な数量だけ使用する事を示しております。
- E. 型式マトリックスリスト 各型式のエンジンは、型式マトリックス欄に○印のある部品により構成されている。
- F. 内容部品表示 この欄に数字の記入されている部品はASM. 部品の内容部品です。
例. SEALING CUP VALVE INSERTはCYL. HEAD ASM. の内容部品であることを示す。
- II. SERVICE CODE (補給形態)
- A. パーツカタログに掲載されている品番を使用し、そのままの形態で補給する。
- B. パーツカタログに掲載品番で補給し、且つブレイクダウンして別に内容部品番号を設定して補給する。
例. STARTER. GENERATOR
- F. KIT又はSETで補給するので、この品番だけは補給しない。
例. ELEMENT
- H. 長尺物形態補給部品、別にサービス用として統一長尺物形態品番を設定して補給するので、この品番では補給しない。
例. VINYL PIPE. RUBBER HOSE.
- Z. 非補給部品
この品番だけでは補給せず、アセンブリ又はブレイクダウンした品番で補給する。
例. INJECTION PUMP ; PROPER
- J. INTERCHANGE-ABILITY (互換性) 設計変更で部品番号が変更される場合に、変更前の部品と変更後の部品が互いに使用出来るかどうかを示しております。
互換性記号 A ; 旧部品と新部品は互いに使用出来る。
B ; 旧部品と新部品は互いに使用出来ない。
C ; 新部品は旧部品に使用出来るがその逆は出来ない。
D ; 廃止になった場合。

E ; 新規追加になった場合。

K. REMARKS

(備考)

この欄には変更切替時期又は変更切替エンジン番号が記載されております。

例. ~ 75-8 75年8月又はエンジンNo. 513635 までこの部品
 又は~ E 513635 を使用。

 75-9~ 75年9月又はエンジンNo. 514800 からこの部品
 又はE 514800~ を使用。

L. NOTE

この欄に表示されております@印はセット又はキットにも含まれています。

M. シート索引番号又は付号

総目次又は目次よりシートを索引するための付号。

A. KEY NO.

The key number is to be used as a reference for locating part number(s) from illustrations or part name.

The index number is given to individual illustrations. The suffix of key number represents that the part number of the parts varies depending on the engine model and does not indicate history of alterations.

B. PART NO.

The numbers consisting of 10 units of figures are used to represent the parts.

The parts, with "N. P. N." (NOT PARTS NUMBER) in the column of the parts number, are not sold independently, however, they are available in assembly, kit or set.

C. PART NAME

A noun that expresses the function or the effect of the part.

D. PER UNIT

This indicates number of parts used in an engine.

The abbreviation "A/R", represents that indicated quantity of parts must be used.

E. List of Type Matrix

Engines of each type consist of the parts indicated by 0 in the type matrix column.

F. List of Component Parts

The component parts indicated by a figure in the column are of assembly parts.

Example: Sealing cup, valve seat insert are indicated to be the component parts of CYL Head Assembly.

H. SERVICE CODE

A. These parts are supplied in the form shown according to the part nos. in the parts catalog.

B. These parts are serviced under the part number(s) listed in the applicable parts catalog.

These parts are also released as individual item using the part number(s) established for each unit.

Example: Starter. Generator.

F. The parts with the code are supplied in KIT or SET only and are not released individually.

Example: Element Kit.

H. Lengthy parts are not supplied as they are by the part nos., since these parts are supplied as package service parts using new part numbers.

Example: Vinyl Pipe. Rubber Hose.

Z. Non supply parts.

These parts are not serviced under the part numbers shown here but are released using part numbers representing assembly or breakdown parts.

Example: Injection pump; proper.

J. INTERCHANGEABILITY**ABILITY**

- When any part number is changed due to a design alteration, the interchangeability code indicates whether or not there is an interchangeability between the parts of new and current designs.

Interchangeability symbols

- A: The old and new parts are mutually interchangeable.
- B: The old and new parts are not mutually interchangeable.
- C: The new part can be used for the old part but reverse case is not applicable.
- D: Abolished
- E: Newly included

D

D-5

K. REMARKS

Effective date of alteration or altered engine numbers are included in this column.

Example:

- 75-8 Applicable to units manufactured before August,
or - E513635 1975 or to engines with serial numbers of up to
 513635.

75-9 - Applicable to units manufactured after Sep-
or E514800 - tember, 1975 or to engines with serial numbers
 of 514800 and onward.

L. NOTE

The parts marked with @ in this column are also included in parts set or kit.

M. Index No. or Code

This is to be used to locate required sheets from the contents.

略 語 表
ABBREVIATIONS

E-1

E

略 語 Abbreviations	原 語 Original words	略 語 Abbreviations	原 語 Original words
— A —		— E —	
A	AMPERE	ENG.	ENGINE
A.C.	ALTERNATING CURRENT	EXC.	EXCEPT
A/CL	AIR CLEANER	EXH.	EXHAUST
ADJ.	ADJUSTER	E#	ENGINE NUMBER
AH	AMPERE HOUR	EXP.	EXPORT
AL.	ALUMINUM	— F —	
A/R	AS REQUIRED	FIG.	FIGURE
ASM.	ASSEMBLY	FLEX.	FLEXIBLE
ATF.	AUTOMATIC TRANSMISSION FLUID	FRT.	FRONT
AUTO.	AUTOMATIC	— G —	
— B —		G	GRAM
B	BREADTH	GEN.	GENERATOR
BRG.	BEARING	GOV.	GOVERNOR
BRKT.	BRACKET	G/RATIO	GEAR RATIO
— C —		— H —	
CARB.	CARBURETOR	H	HIGH
CF.	CONFER	HD.	HEAD
CMPR.	COMPRESSOR	HEX.	HEXAGON
COMB.	COMBINATION	HP	HORSE POWER
COMPL.	COMPLETE	HSG.	HOUSING
CONN.	CONNECTING	— I —	
CONT.	CONTROL	I.D.	INSIDE DIAMETER
CYL.	CYLINDER	IGN.	IGNITION
— D —		INCL.	INCLUDING
D	DIAMETER	INJ.	INJECTION
D.C.	DIRECT CURRENT	INL.	INLET
DIAPH.	DIAPHRAGM	INT.	INTAKE
DISTR.	DISTRIBUTOR	— K —	
		KG	KILOGRAM

略 語 表
ABBREVIATIONS

略 語 Abbreviations	原 語 Original words		略 語 Abbreviations	原 語 Original words	
KM/H	KILOMETER HOUR	キロメートル アワー	RHD.	RIGHT HAND DRIVE	ライト ハンド ドライブ(右ハンドル車)
KW	KILOWATT	キロワット	RR.	REAR	リヤ
- L -			- S -		
L	LITER (LITRE)	リッター	SPD.	SPEED	スピード
L1=	LENGTH (VERTICAL)	たて寸法	SPR.	SPRING	スプリング
L2=	LENGTH (SIDE)	よこ寸法	STD.	STANDARD	スターダード
L=	LENGTH	レングス(長さ)	SW.	SWITCH	スイッチ
LH.	LEFT HAND	レフト ハンド(左)	- T -		
LK.	LOCK	ロック	T=	THICKNESS	シクネス(厚さ)
LWR.	LOWER	ロワー	TAP.	TAPPING	タッピング
- M -			TEMP.	TEMPERATURE	テンプレチャー(温度)
MAN.	MANUAL	マニュアル	T/V	THROTTLE VALVE	スロットルバルブ
MANIF.	MANIFOLD	マニホールド	- U -		
MTG.	MOUNTING	マウンティング	UNSI.	UNDER SIZE	アンダー サイズ
MM	MILLIMETER	ミリメートル	UPR.	UPPER	アッパー
- N -			- V -		
NO.	NUMBER	ナンバー	V	VOLT	ボルト(電圧)
N.P.N.	NOT PART NUMBER	ノット パーツ ナンバー(品番なし)	VAC.	VACUUM	バキューム
- O -			VLV.	VALVE	バルブ
O.D.	OUTSIDE DIAMETER	アウトサイド ダイアメーター	- W -		
OPT	OPTION	オプション	W	WATT	ワット
OVS.	OVER SIZE	オーバー サイズ	W/	WITH	ウイズ(～付)
- P -			WO/	WITH OUT	ウイズアウト(なし)
PL.	PLAIN	ブレイン	- Z -		
PS	PFERDESTARKE	馬力	Z	TEETH	歯数
P.T.O.	POWER TAKE OFF	パワー テーク オフ	&	AND	アンド(～と)
- R -			"	INCH	インチ
REG.	REGULATOR	レギュレーター	#	NUMBER	ナンバー
RET.	RETAINER	リテイナー			
RH.	RIGHT HAND	ライト ハンド			

REPAIR KIT ENGINE OVERHAUL (3AE1)

F-1



ILLUSTRATION & KEY NO.	PART NAME	PER UNIT	KIT NO.	INTER-CHANGE ABILITY	KIT NO.	INTER-CHANGE ABILITY	KIT NO.	INTER-CHANGE ABILITY	KIT NO.
			5-8781-0165-0		5-8781-0165-1		5-8781-0165-2		
			对照 ENGINE NO.		对照 ENGINE NO.		对照 ENGINE NO.		
			539934~		~		~		
			PART NO. IN KIT	C	PART NO. IN KIT		PART NO. IN KIT		PART NO. IN KIT
(1) 21-1	GASKET; CYL. HEAD	1	5-11141-047-0	C	_____		_____		_____
(1) 49	PACKING; O-RING, HEAD COVER	1	9-11173-137-0		_____		_____		
(1) 32	PACKING; HEAD COVER NUT	2	9-11179-030-0		_____		_____		
(2) 25	SEAL; OIL, CRANKSHAFT	1	9-09924-449-0		5-09625-036-0		_____		
(2) 52-1	PACKING; FRONT PLATE	1	5-11312-023-0		_____		_____		
(4) 3-1	PACKING; COVER A	1	5-11312-028-0		_____		_____		
(4) 3-2	PACKING; COVER B	1	5-11312-025-0		_____		_____		
(3) 19	SEAL; OIL, GEAR CASE	1	9-09924-448-0		5-09625-079-0		_____		
(3) 22	PACKING; GEAR CASE COVER	1	9-11322-083-0		_____		_____		
(3) 22-1	PACKING; GEAR CASE FRONT	1	5-11322-035-0	_____	_____				
(3) 33	PACKING; GEAR CASE, O-RING	1	5-09623-034-0	A	5-09623-073-0		_____		_____
(3) 40	PACKING; SPACER	1	5-11319-079-0		_____		_____		
(3) 42	RUBBER; SEAL	1	5-19387-001-1		_____		_____		
(3) 43	RUBBER; SEAL, COVER	1	5-19387-002-0		_____		_____		
(3) 44	GROMMET	6	5-19389-002-0		_____		_____		
(3) 45	BUSH; GROMMET	6	5-19389-005-0		_____		_____		
(5) 10-1	PACKING; OIL PAN-CYL. BLOCK	1	5-11367-039-0		5-11367-039-1		_____		
(5) 29	PACKING; OIL PAN-BRG. CASE	2	9-11258-108-0		_____		_____		
(9) 33	RING; SEALING, VALVE	6	9-12559-008-0		_____		_____		
(10) 45	PACKING; OIL FILTER-CYL.	1	5-13219-014-0		_____		_____		
(11) 4	PACKING; OIL PIPE	2	9-09920-900-0		_____		_____		_____
(12) 32	PACKING; PUMP-CYL. BLOCK	1	5-13619-098-2		_____		_____		
(12) 34	PACKING; PUMP-CYL. HEAD	1	5-09623-031-0		_____		_____		
(12) 57	PACKING; OUTLET PIPE	1	5-09637-013-0		_____		_____		
(13) 46	GASKET; INLET AND EXH. MANI.	1	9-14146-090-0		_____		_____		
(13) 62	PACKING; INTAKE SHUTTER	3	5-09637-015-0		_____		_____		
(15) 9	WASHER; CORRUGATED	3	9-15315-074-0		_____		_____		
(15) 6	HEAT SHIELD; NOZZLE	3	9-15315-027-0		_____		_____		
(15) 7	WASHER; NOZZLE HOLDER	3	9-15315-026-0		_____		_____		
(15) 33	PACKING; JOINT BOLT	4	9-0957-2012-0		_____		_____		
(18) 45	PACKING; O-RING	1	5-09623-019-0	E	_____		_____		_____
(19) 50-1	PACKING; BRKT.-PLATE	1	5-11319-077-0		_____		_____		
(12) 34	PACKING; PUMP-CYL. HEAD	1			5-13743-019-0		_____		

(F)

REPAIR KIT ENGINE OVERHAUL (3AF1)

ILLUSTRATION & KEY NO.	PART NAME	PER UNIT	KIT NO.	INTER-CHANGE ABILITY	KIT NO.	INTER-CHANGE ABILITY	KIT NO.	INTER-CHANGE ABILITY	KIT NO.
			5-8781-0166-0		5-8781-0166-1		5-8781-0166-2		
			对照 ENGINE NO.		对照 ENGINE NO.		对照 ENGINE NO.		
			539934~		~		~		~
			PART NO. IN KIT	C	PART NO. IN KIT		PART NO. IN KIT		PART NO. IN KIT
(1) - 21	GASKET; CYL. HEAD	1	5-11141-048-0		_____		_____		_____
(1) - 49	PACKING; O-RING HEAD COVER	1	9-11173-137-0		_____		_____		_____
(1) - 32	PACKING; HEAD COVER NUT	2	9-11179-030-0		_____		_____		_____
(2) - 25	SEAL; OIL, CRANKSHAFT	1	9-09924-449-0	C	5-09625-036-0		_____		_____
(2) - 52	PACKING; PLATE	1	5-11312-026-0		_____		_____		_____
(3) - 3	PACKING; GEAR CASE COVER	1	9-11322-066-0		_____		_____		_____
(3) - 5	PACKING; GEAR CASE	1	9-11312-803-0		_____		_____		_____
(3) - 19	SEAL; OIL GEAR CASE	1	9-09924-448-0	C	5-09625-079-0		_____		_____
(3) - 22	PACKING; GEAR CASE COVER	1	9-11322-083-0		_____		_____		_____
(5) - 10	PACKING; OIL PAN-CYL. BLOCK	1	5-11367-051-0		_____		_____		_____
(9) - 33	RING; SEAL, VALVE	6	9-12559-008-0		_____		_____		_____
(10) - 45	PACKING; OIL FILTER	1	5-13219-014-0		_____		_____		_____
(11) - 4	PACKING; OIL PIPE	2	9-09920-900-0		_____		_____		_____
(12) - 32	PACKING; PUMP-CYL. BLOCK	1	5-13619-098-2		_____		_____		_____
(12) - 34	PACKING; PUMP-CYL. HEAD	1	5-09623-031-0		_____		_____		_____
(12) - 57	PACKING; OUTLET PIPE	1	5-09637-013-0		_____		_____		_____
(13) - 46	GASKET; INLET AND EXH. MANI.	1	9-14146-090-0		_____		_____		_____
(13) - 62	PACKING; INTAKE SHUTTER	3	5-09637-015-0		_____		_____		_____
(18) - 6	HEAT SHIELD; NOZZLE	3	9-15135-027-0		_____		_____		_____
(18) - 9	WASHER; CORRUGATED	3	9-15315-074-0		_____		_____		_____
(18) - 7	WASHER; NOZZLE	3	9-15315-026-0		_____		_____		_____
(18) - 33	PACKING; JOINT BOLT	4	9-0957-2012-0		_____		_____		_____
(18) - 45	PACKING; O-RING	1	5-09623-019-0		_____		_____		_____
(18) - 50	PACKING; BRKT.-PLATE	1	9-09921-246-0		_____		_____		_____
(12) - 34	PACKING; PUMP-CYL. HEAD	1				E	5-13743-019-0		

KIT にて補給する部品 (補給形態 F)
 PARTS LIST TO BE SUPPLIED BY KIT OR SET (SHAPE CODE : F)

F-3

F

イラスト&KEY No. ILLUSTRATION & KEY NO.	補給形態品番 SHAPE CODE PARTS NO.	部 品 名 称 PARTS NAME	単位数 PER UNIT	KIT の内容に含まれる部品の KEY No. KEY NO. OF THE PARTS CONTENT IN KIT
⑥-1	913120-6010	ROTOR SET; OIL PUMP	1	⑥-6, 9, 10, 11
⑩-72-1	587810-1780	ELEMENT KIT; FUEL FILTER	1	⑩-65, 70, 72, 74
⑫-1, 1-1	894211-4390	REPAIR KIT; WATER PUMP	1	⑫-6, 8, 10, 12

CYL. HEAD & COVER OTHER PARTS(HEAD COVER)

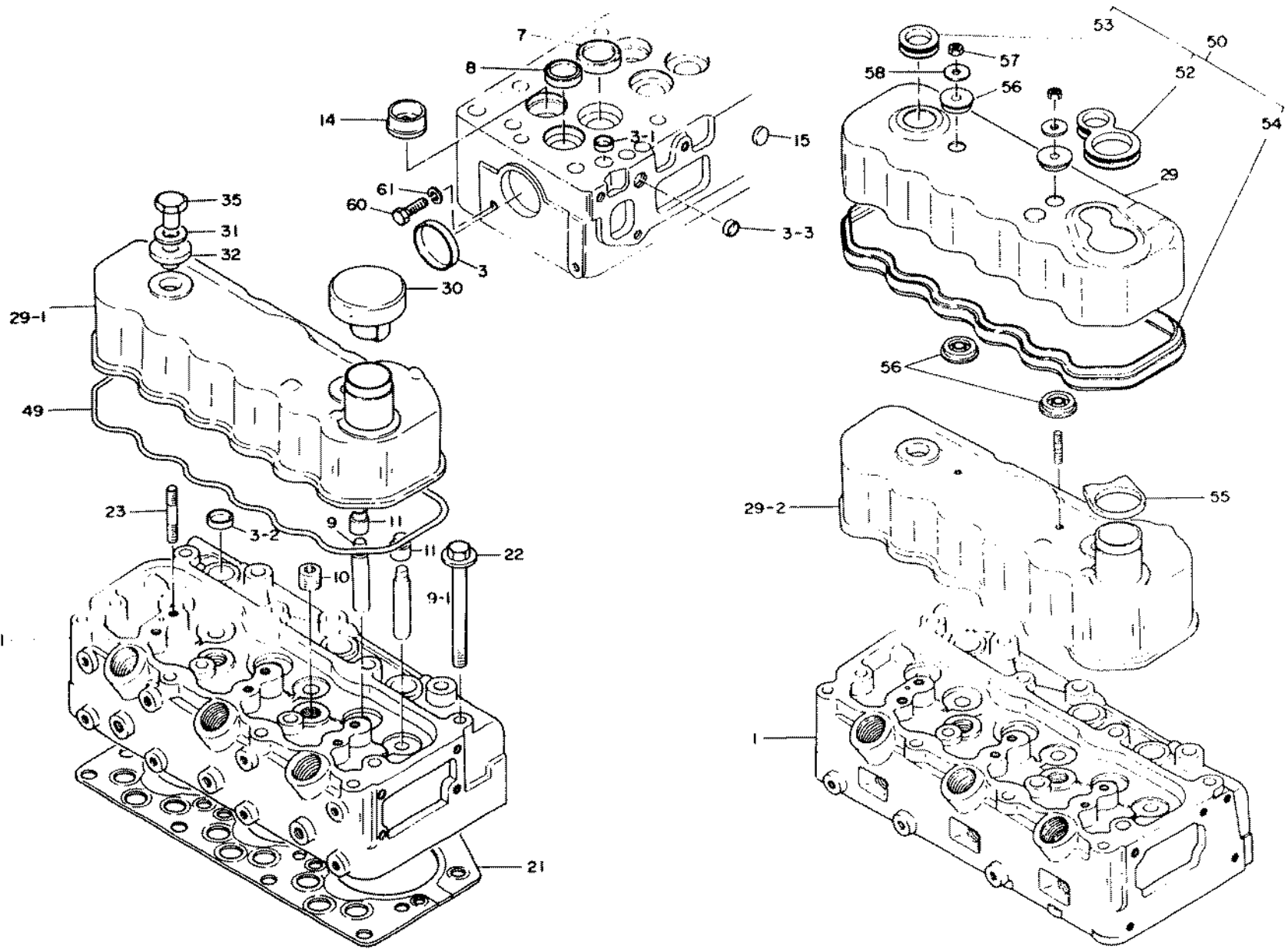

		3AF1		3AE1 Engine Type						
		BBBBB:SBBBB:SSE								
		B LLL:T 00B:TT								
		00:D 12 :DD								
		12: 0								
		: 1								
Key No.	Part No.	Part Name	Per Unit	L	S	I	T	C	Remarks	NOTE
1	511110-1781	HEAD ASM.:CYL.	1	00	:	0	:			
1	511110-1783	HEAD ASM.:CYL.	1	00	:	0	:			
1	511110-1921	HEAD ASM.:CYL.	1	000	:		:			
1	511110-1923	HEAD ASM.:CYL.	1	000	:		:			
1	511110-1771	HEAD ASM.:CYL.	1		:	0000:0 0	:			
1	511110-1772	HEAD ASM.:CYL.	1		:	0000:0 0	:			
1	511110-1773	HEAD ASM.:CYL.	1		:	0000:000	:			
3	911129-0060	CUP:SEALING,REAR,FASE	1	00000	:	00000:000	:			
3	911129-0810	CUP:SEALING,REAR,FASE	3	00000	:	00000:000	:			
3	911129-0820	CUP:SEALING,REAR,FASE	3	00000	:	00000:000	:			
3	911129-0830	CUP:SEALING,DRILLED PASS	3	00000	:	00000:000	:			
7	511715 0200	SEAT:VALVE,INSERT,INLET	3	00000	:	00000:000	:			
8	511711 0230	SEAT:VALVE,INSERT,EXH.	3	00000	:	00000:000	:			
9	911721 1130	GUIDE,VALVE,INLET	3	00000	:	00000:000	:			
9	511721 0130	GUIDE,VALVE,EXH.	3	00000	:	00000:000	:			
10	909664-0340	PLUG;1/2,UPPER,FASE	2	00000	:	00000:000	:			
11	512569-0040	SEAL:VALVE	6	00000	:	00000:000	:			
14	511150-1180	PLUG ASM.;HOT	3	00000	:	0	:			
14	511150-1170	PLUG ASM.;HOT	3		:	0000:000	:			
15	909860-5220	PLUG;PLATE,CYL.HEAD	3	00000	:	00000:000	:			
21	511141-0480	GASKET;CYL.HEAD	1	00000	:	0	:			
21	511141-0470	GASKET;CYL.HEAD	1		:	0000:000	:			
22	909802-5141	BOLT	15	00000	:	0000:	:			
22	509009-0360	BOLT	15	00000	:	00000:000	:			
23	904100-8250	STUD;HEAD COVER	2	0000	:	0000:0 0	:			
29	511170-2580	COVER ASM.;CYL.HEAD	1	000	:		:			
29	511170-1422	COVER ASM.;CYL.HEAD	1	0	:	0 0:000	:			
29	511170-2551	COVER ASM.;CYL.HEAD	1	0	:	000	:			
30	911750-8020	CAP ASM.;CYL.HEAD COVER	1	00000	:	00000:000	:			
31	911179-1050	WASHER	2	00000	:	00000:000	:			
32	911179-0300	PACKING;CYL.HEAD COVER	2	00000	:	00000:000	:			
35	911175-0110	NUT;HEAD COVER	2	00000	:	00000:0	:			
35	911175-0120	NUT;HEAD COVER	2	00000	:	00000:000	:			
49	911173-1370	PACKING;O-RING,CYL.HEAD	1	00000	:	00000:000	:			
50	519380-0200	COVER ASM.;HEAD COVER	1	0000	:	000:	:			
52	519389-0030	GROMMET	1	0000	:	000:	:			
53	119389-0040	GROMMET	1	0000	:	000:	:			
54	519387-0030	RUBBER;SEAL	1	0000	:	000:	:			
55	519389-0040	SPACER;GROMMET	1	0000	:	000:	:			
56	119389-0050	RUBBER;MTG.	4	0000	:	000:	:			
56	519389-0060	RUBBER;MTG.	4	0000	:	000:	:			
57	909110-5080	NUT;COVER	2	0000	:	000:	:			
58	909160-7080	WASHER;PL.	2	0000	:	000:	:			
60	909202-0080	PLUG;SCREW	1	000	:		:			
61	909920-8430	PACKING;PLUG	1	000	:		:			

CYL. BLOCK & OTHER PARTS

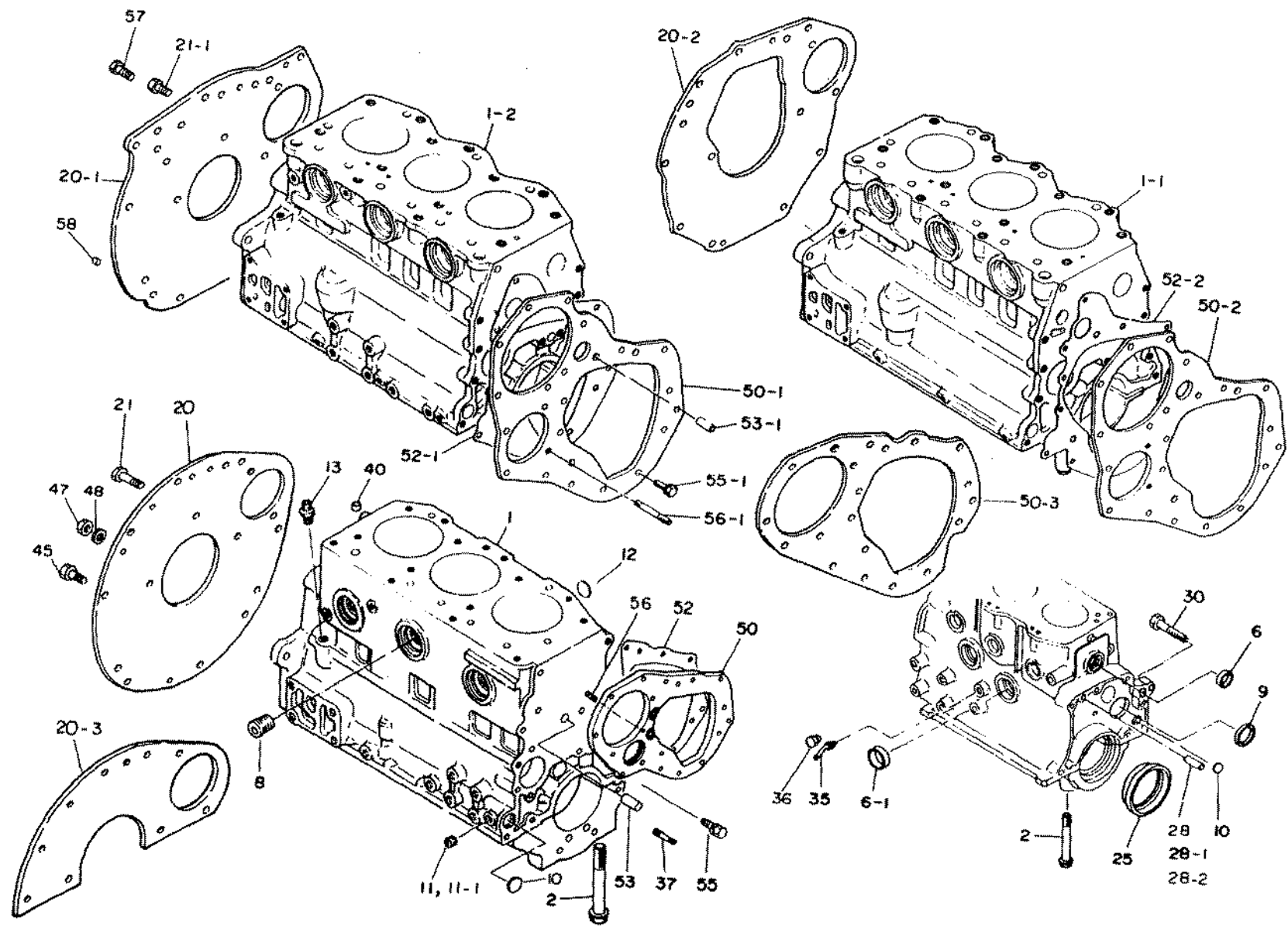

Key No.	Part No.	Part Name	Per Unit	3AF1		3AE1		Engine Type		L	S · C	I T C	Remarks	NOTE
				BBBBB	SBBBB	SSE	B	LLL	T					
				00	0									
				00	0									
				000										
				000										
				000										
					0000	0								
					0000	0000	0000							
					00000	00000	0000							
					00000	00000	0000							
					00000	00000	0000							
8	909664-0340	PLUG; 1/2 TAPPET CHAMBER	3	00000	00000	0000				1	A			
9	909201-0560	PLUG; PLATE, CAM BRG.	1	00000	0000						A			
9	909201-3560	PLUG; PLATE, CAM BRG.	1	00000	00000	0000					A			
10	909201-3180	PLUG; PLATE, OIL GALLERY	2	00000	00000	0000					A			
11	509605-0191	PLUG; 1/8, TAPER, OIL GALLER	2	0	0						A			
11	509605-0191	PLUG; 1/8, TAPER, OIL GALLER	3	0000	0000	0000					A			
12	909201-3450	PLUG; PLATE, TAPPET, CHAMBER	3	00000	00000	0000					A			
13	909902-2990	NIPPLE; ROCKER, OIL FEED	1	00000	00000	0000					A			
20	511341-0960	PLATE; REAR, CYL. BLOCK	1	0	0						A			
20	511341 0862	PLATE; REAR, CYL. BLOCK	1	0	000						A			
20	511341-1050	PLATE; REAR, CYL. BLOCK	1	0	000						A			
20	511341-0910	PLATE; REAR, CYL. BLOCK	1	000							A			
20	511341-1940	PLATE; REAR, CYL. BLOCK	3	0	0	00					A			
21	909800-6840	BOLT; REAR, PLATE FIX.	1	000							A			
21	509000-2270	BOLT; REAR, PLATE FIX.	2	000							A			
21	509000-2270	BOLT; REAR, PLATE FIX.	3	00	00000	0					A			
25	909924-4490	SEAL; OIL, CRANK SHAFT	1	00000	0000						A			
25	509625-0360	SEAL; OIL, CRANK SHAFT	1	00000	00000	0000					A			
28	908161-0320	PIN; STRAIGHT	1	00	00000	0000					A			
28	908161-0280	PIN; STRAIGHT	1	000							A			
28	908151-0180	PIN; STRAIGHT	1	00000	0000						A			
30	989112-9110	BOLT; REAMER	1	00000	00000	0000					A			
35	513721-0430	DRAIN PIPE; WATER	1	00000	0000						A			
36	909664-0010	PLUG; WATER, DRAIN	1	0	0	000					A			
37	509300-0451	STUD; GEAR CASE	1	0	0						A			
37	509300-0550	STUD; GEAR CASE	1	0	0	000					A			
40	911229-0490	DOWEL	2	00000	00000	0000					A			
45	901911-0200	BOLT; REAR, PLATE	3	00	00000	0					A			
45	901911-0200	BOLT; REAR, PLATE	1	000							A			
47	909110-4100	NUT; REAMER	1	00000	00000	0000					A			
48	909150-5100	WASHER; SPR.	1	00000	00000	0000					A			
50	511311-0540	PLATE; FRT. CYL. BLOCK	1	0	0						A			
50	511311-0491	PLATE; FRT. CYL. BLOCK	1	0	000						A			
50	511311-0570	PLATE; FRT. CYL. BLOCK	1	000							A			
50	511311-0790	PLATE; FRT. CYL. BLOCK	1	000							A			
50	511311-0380	PLATE; FRT. CYL. BLOCK	3	0	0	000					A			
52	511312-0260	PACKING; FRT. CYL. PLATE	1	0	0	0000					A			
52	511312-0230	PACKING; FRT. CYL. PLATE	1	0	000						A			
52	511312-0300	PACKING; FRT. CYL. PLATE	1	000							A			
53	908151-0300	PIN; STRAIGHT	2	0	0						A			

2

2-3

Key No.	Part No.	Part Name	Per Unit	3AF1		3AE1		Engine Type		L	S C	I T C	Remarks	NOTE	
				BBBBB	SBBBB	SSE	B	LLL	T						OOB
53	1	908151-0220	PIN; STRAIGHT	2	0000	0000	000								
55		901900-8220	BOLT; SEMS, FRT. PLATE	3	0		0	00							
55	1	901900-8200	BOLT; SEMS, FRT. PLATE	4	0000	000									
56		904110-8220	STUD; INJ. BRKT.	1	0		0								
56	1	509300-0431	STUD; HYDRAULIC	2	0000	000									
57		901931-2250	BOLT; RR. PLATE	2	0		000								
58		509740-0150	PIN; STRAIGHT	1	0000	000									

MEMO

TIMING GEAR CASE & OTHER PARTS

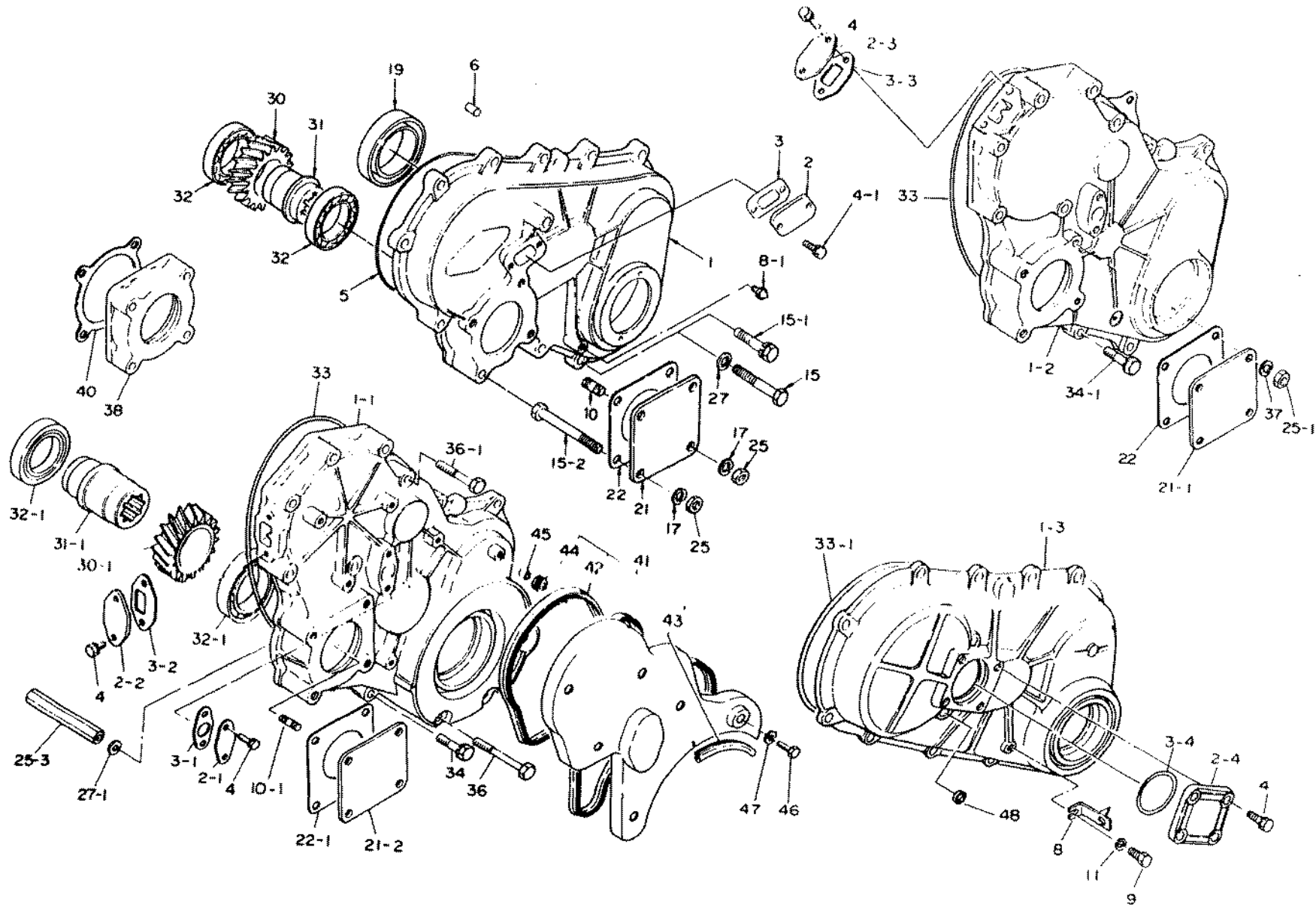

Key No.	Part No.	Part Name	Per Unit	3AF1		3AE1		Engine Type		L	S · C	I T C	Remarks	NOTE
				BBBBB	SBBBB	SSE	B	LLL	T					
				00:D	12	:DD	:	:	:					
				12:	0	:	:	:	:					
				:	1	:	:	:	:					
1	511311-0532	CASE; GEAR, TIMING	1	0	:	0	:	0	:		A			
1 1	511311-0700	CASE; GEAR, TIMING	1	0	:	000	:	:	:		A			
1 2	511311-0760	CASE; GEAR, TIMING	1	000:	:	:	:	:	:		A			
1 3	511311-0741	CASE; GEAR, TIMING	1	0	:	0	:	0	:		A			
2	911321-1370	COVER; GEAR CASE	1	0	:	0	:	0	:		A			
2 1	511321-0590	COVER; A, GEAR CASE	1	0000:	:	000	:	:	:		A			
2 2	511321-0540	COVER; B, GEAR CASE	1	0	:	000	:	:	:		A			
2 3	511321-0600	COVER; B, GEAR CASE	1	000:	:	:	:	:	:		A			
2 4	911321-1480	COVER; GEAR CASE	1	0	:	0	:	0	:		A			
3	911322-0660	PACKING; GEAR CASE, COVER	1	0	:	0:	:	:	:		A			@
3	511322-0541	PACKING; GEAR CASE, COVER	1	0	:	0:	:	0	:		A	A		@
3 1	511312-0280	PACKING; COVER, A	1	0000:	:	000	:	:	:		A			@
3 2	511312-0250	PACKING; COVER, B	1	0	:	000	:	:	:		A			@
3 3	511312-0290	PACKING; COVER, B	1	000:	:	:	:	:	:		A			
3 4	909920-6010	PACKING; GEAR CASE, COVER	1	0	:	0	:	0	:		A			
4	901900-6120	BOLT; SEMS	4	0000:	:	0000	:	0	:		A			
4 1	901900-6120	BOLT; SEMS	2	0	:	0	:	0	:		A			@
5	911312-8030	PACKING; GEAR CASE	1	0	:	0	:	0	:		A			
5 1	911312-0460	PACKING; GEAR CASE	2	0000:	:	000	:	:	:		A			
5 1	911312-0460	PACKING; GEAR CASE	1	0	:	000	:	:	:		A			
5 2	911312-0340	PACKING; GEAR CASE	1	0	:	0	:	0	:		A			
6	511319-1150	BUSH; GEAR CASE	1	0	:	0	:	000	:		A			
8	911327-0450	POINTER; TIMING, GEAR CASE	1	0	:	0	:	000	:		A			
8 1	511327-0120	POINTER; TIMING, GEAR CASE	1	0	:	0:	:	:	:		A			
9	992040-5100	BOLT; POINTER FIX.	1	0	:	0:	:	:	:		A			
10	904110-8200	STUD; HYDRAULIC, PUMP	4	0000:	:	000	:	:	:		A			
10 1	904110-8200	STUD; HYDRAULIC, PUMP	3	0	:	0:	:	:	:		A			
10 1	904110-8550	STUD; HYDRAULIC, PUMP	2	0000:	:	000	:	:	:		A			
10 2	904110-8200	STUD; HYDRAULIC, PUMP	2	0	:	0	:	0	:		A			
11	909150-5050	WASHER; SPR.	1	0	:	0:	:	:	:		A			
15	901055-8550	BOLT; GEAR CASE	2	0	:	0:	:	:	:		A			
15	509000-0840	BOLT; GEAR CASE	2	0	:	0:	:	:	:		A			
15 1	509030-0150	BOLT; SEMS, GEAR CASE	6	0	:	0:	:	:	:		A	C		(-79-12)
15 2	901055-8750	BOLT; GEAR CASE	1	0	:	0:	:	:	:		A			
15 3	901910-8320	BOLT; GEAR CASE	8	0	:	00	:	:	:		A			
17	909150-5080	WASHER; SPR.	1	0	:	0	:	0	:		A			
19	909924-4480	SEAL; OIL	1	00000:	:	0000	:	:	:		A			
19	509625-0790	SEAL; OIL	1	00000:	:	00000	:	000	:		A	C		(-81-2)
25 4	909110-4080	NUT	1	0	:	0	:	0	:		A			@
21	911321-1790	COVER; GEAR CASE	1	00	:	0000:	:	:	:		A			
21 1	911321-1790	COVER; GEAR CASE	2	000:	:	:	:	:	:		A			
21 1	911321-1790	COVER; GEAR CASE	1	000:	:	:	:	:	:		A			
21 2	511321-0830	COVER; FRONT, GEAR CASE	1	00000:	:	000	:	:	:		A	A		(-80-8)
22	911322-0830	PACKING; GEAR CASE, COVER	1	00000:	:	0000	:	:	:		A			@
22 1	511322-0351	PACKING; GEAR CASE, FRONT	1	0000:	:	0000:	:	:	:		A			@
25	909110-4080	NUT	4	0	:	0:	:	:	:		A			
25 1	909110-4080	NUT	8	0000:	:	000	:	:	:		A			
25 2	909110-4080	NUT	7	0	:	000	:	:	:		A			
25 3	509449-0180	NUT	1	0	:	000	:	:	:		A	D		(-79-12)
25 3	909110-4080	NUT	1	0	:	0	:	0	:		A	E		(-79-12) (80-11-)

3

3-3

Key No.	Part No.	Part Name	Per Unit	3AF1		3AE1		Engine Type		L	S C	I T C	Remarks	NOTE
				BBBBB	SBBBB	SSE	B	LLL	T					
25	4	909110-4080	NUT	1			0				A			
27		909150-5080	WASHER; SPR.	8	0		0				A			
27	1	909150-5080	WASHER; SPRING	4		000					A	D	(-79-12)	
27	2	909150-5080	WASHER; SPR.	8	0000	000					A	E	(80-9-)	
27	3	909150-5080	WASHER; SPR.	1			0				A			
30		912525-8010	GEAR; HYDRAULIC, PUMP DRIVE	1	0		0				A		(-81-2)	
30		912525-8011	GEAR; HYDRAULIC, PUMP DRIVE	1	0		0				A	C		
30	1	512525-0111	GEAR; HYDRAULIC, PUMP DRIVE	1	0000	000					A		(-81-2)	
30	1	512525-0112	GEAR; HYDRAULIC, PUMP DRIVE	1	0000	000					A	C		
31		912533-8010	SHAFT; DRIVE GEAR	1	0		0				A			
31	1	512533-0100	SHAFT; DRIVE GEAR	1	0000	000					A		(-81-2)	
31	1	512533-0101	SHAFT; DRIVE GEAR	1	0000	000					A	C		
32		900090-6670	BEARING; BALL	2	0		0				A			
32	1	509800-0300	BEARING; BALL	2	0000	000					A			
33		509623-0340	PACKING; GEAR CASE, O-RING	1	0000	000					A		(-81-2)	
33		509623-0730	PACKING; GEAR CASE, O-RING	1	0000	000					A	C		
33	1	509623-0340	PACKING; GEAR CASE, O-RING	1		0	0				A			
34		901910-8300	BOLT; SEMS, GEAR CASE	5	0		000				A			
34		901910-8320	BOLT; SEMS, GEAR CASE	8		0	0				A			
34	1	901910-8300	BOLT; SEMS, GEAR CASE	6	000						A		(-80-8)	
34	1	901910-8300	BOLT; SEMS, GEAR CASE	3	000						A	A		
36		509000-0970	BOLT; GEAR CASE	3	0		000				A			
36	1	509000-0940	BOLT; GEAR CASE	1	0		000				A		(-80-8)	
36	1	509030-0370	BOLT; GEAR CASE	1	0		000				A	C		
36	1	509030-0370	BOLT; GEAR CASE	4	000						A			
37		909150-5080	WASHER; SPR.	4	0		0				A			
38		511319-0780	SPACER; HYDRAULIC	1	0000	000					A			
40		511319-0790	PACKING; SPACER	1	0000	000					A			
41		519380-0192	COVER ASM, GEAR CASE	1	0		000				A			
42		519387-0011	RUBBER; SEAL, COVER	1	0		000				A			
43		519387-0020	RUBBER; SEAL, COVER	1	0		000				A			
44		519389-0020	GROMMET	6	0		000				A			
45		519389-0050	BUSH; GROMMET	6	0		000				A			
46		901910-6160	BOLT; SEMS, COVER FIX.	6	0		000				A			
47		909160-6060	WASHER; PL.	6	0		000				A			
48		911312-0460	PACKING; GEAR CASE	1		0	0				A			

MEMO

FLY WHEEL HOUSING & OTHER PARTS

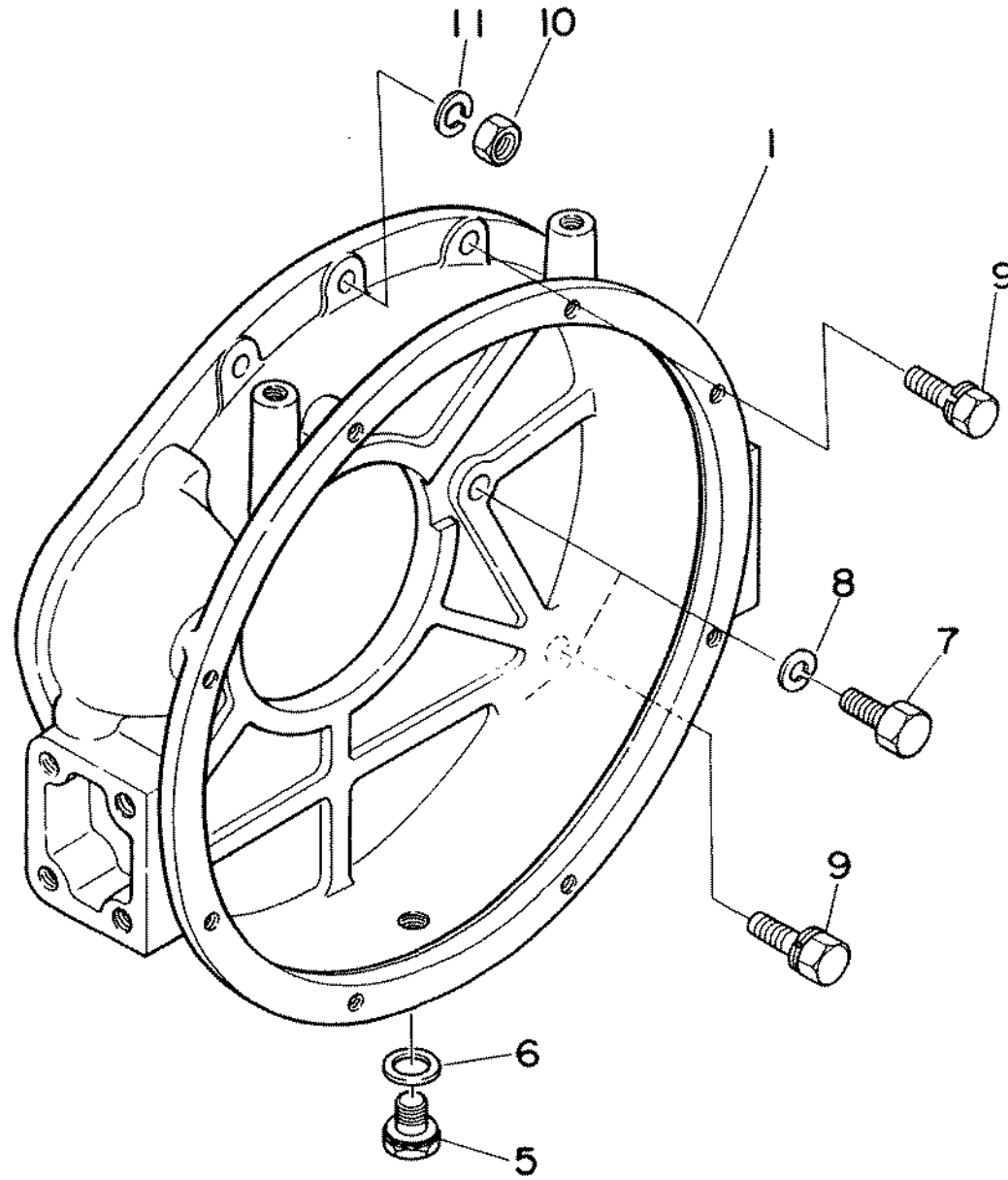

OIL PAN & OTHER PARTS

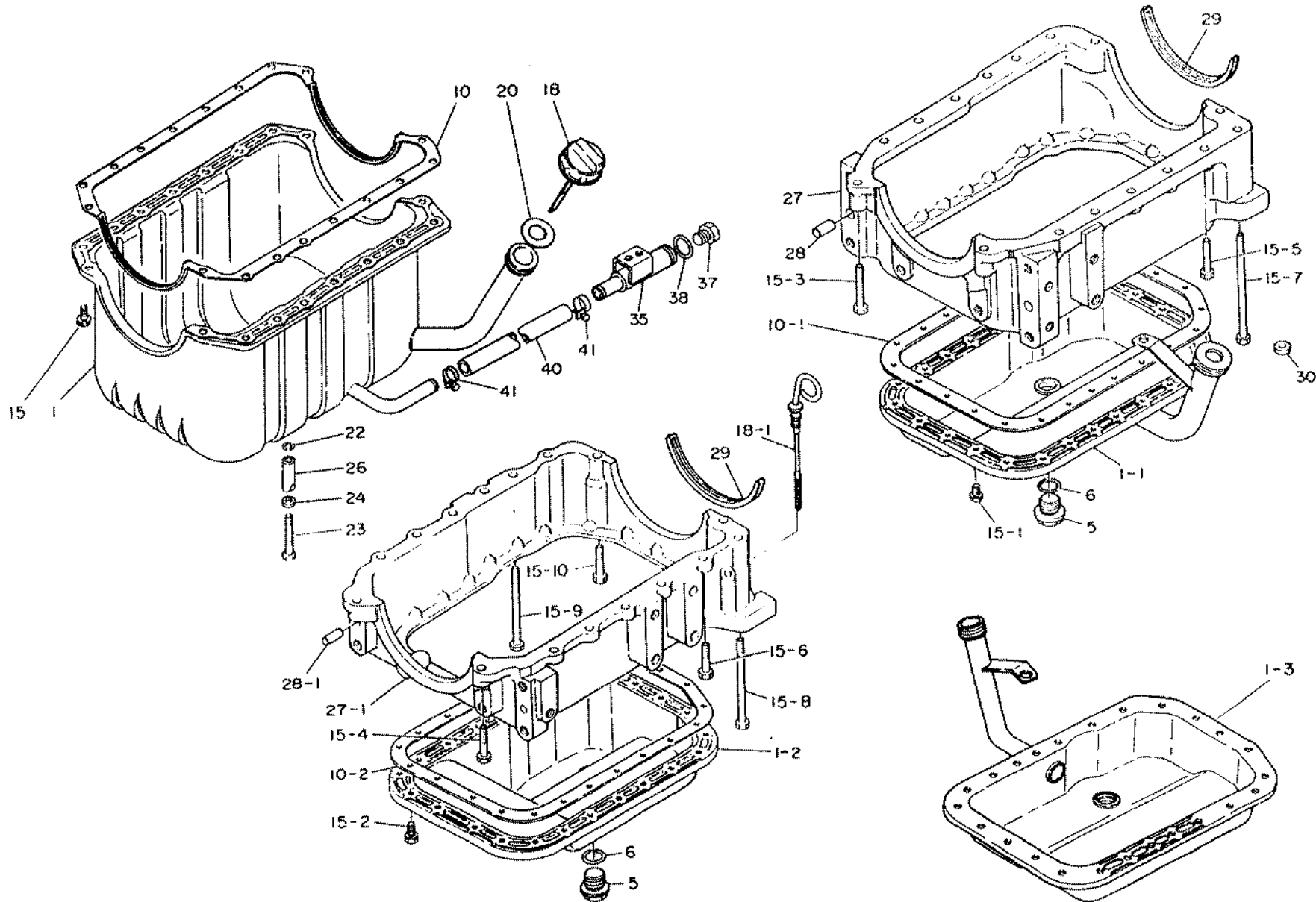

Key No.	Part No.	Part Name	Per Unit	3AF1		3AE1 Engine Type		L	S	I	T	C	Remarks	NOTE
				BBBBB	SBBBB	SSE	B							
				00:D	12	:DD	0							
				12:	0		1							
1	511361-1120	PAN;OIL W/OIL FILLER	1	0	0									
1 1	511360-3990	PAN ASM.;OIL	1	0	000				A					
1 2	511360-4760	PAN ASM.;OIL	1	000					A					
1 3	511360-4770	PAN ASM.;OIL	1	0	0				A					
1 4	511360-5000	PAN ASM.;OIL	1			00			A					
5	909662-0120	PLUG;DRAIN	1	0000	0000	000			A					
6	909920-6510	PACKING;O-RING	1	0000	0000	000			A					
10	511367-0511	PACKING;OIL PAN-CYL.BLOCK	1	0	0	0:0			A					
10 1	511367-0390	PACKING;OIL PAN-CYL.BLOCK	1	0	000				A				(-80-4)	@
10 1	511367-0392	PACKING;OIL PAN-CYL.BLOCK	1	0	000	00			A					@
10 2	511367-0470	PACKING;OIL PAN-CYL.BLOCK	1	000					A				(-80-4)	
10 2	511367-0472	PACKING;OIL PAN-CYL.BLOCK	1	000					A					
15	901910-8160	BOLT;SEMS.OIL PAN FIX.	14	0	0	0:0			A					
15 1	901910-6160	BOLT;SEMS.OIL PAN FIX.	24	0	000				A				(-80-7)	
15 1	901970-6160	BOLT;SEMS.OIL PAN FIX.	24	0	0000	00			A					
15 2	901910-6120	BOLT;OIL PAN FIX.	23	000					A					
15 3	901065-8450	BOLT;OIL PAN FIX.	5	0	000	00			A					
15 4	901065-8320	BOLT;OIL PAN FIX.	2	000					A				(-80-8)	
15 4	901065-8350	BOLT;OIL PAN FIX.	8	000					A					
15 5	901065-8350	BOLT;OIL PAN FIX.	9	0	000	00			A					
15 6	902060-8250	BOLT;OIL PAN FIX.	10	000					A				(-80-8)	
15 6	901065-8650	BOLT;OIL PAN FIX.	2	000					A					
15 7	909600-0820	BOLT;OIL PAN FIX.	2	0	000	00			A					
15 8	509000-2000	BOLT;OIL PAN FIX.	2	000					A					
15 9	901065-8900	BOLT;OIL PAN FIX.	1	000					A				(-80-8)	
15 9	909801-2740	BOLT;OIL PAN FIX.	2	000					A					
15 10	901065-8400	BOLT;OIL PAN FIX.	1	000					A					
18	511760-0920	GAUGE ASM.;OIL	1	0	000	00			A					
18	511760-0920	GAUGE ASM.;OIL	1	0	0	0:0			A				(-80-11)	
18	511760-1400	GAUGE ASM.;OIL	1	0	0	0:0			A					
18 1	511760-1240	GAUGE ASM.;OIL	1	000					A				(-81-2)	
18 1	511760-1243	GAUGE ASM.;OIL	1	000					A					
20	909920-6090	PACKING	1	00	00000	00			A					
22	909150-5080	WASHER;SPR.	16	0	0				A				(-80-8)	
22	909150-5080	WASHER;SPR.	16	0000	000	000			A					
22 1	909164-7080	WASHER;PL.	1	0	000	00			A					
23	901055-8600	BOLT;OIL PAN FIX.	2	0	0	0:0			A				(-80-5)	
23	509000-0840	BOLT;OIL PAN FIX.	2	0	0	0:0			A					
23 1	901910-8200	BOLT;OIL PAN FIX.	2	0	0	0:0			A					
24	509503-0310	WASHER;OIL PAN FIX.	2	0	0	0:0			A					
26	589113-6150	TUBE;DIST	2	0	0	0:0			A					
27	511215-0540	CASE;CHANK	1	0	000				A				(-80-7)	
27	511215-0541	CASE;CRANK	1	0	000	00			A					
27 1	511215-0611	CASE;CRANK	1	000					A				(-80-8)	
27 1	511215-0790	CASE;CRANK	1	000					A					
28	908151-2220	PIN;STRAIGHT,CRANK CASE	2	0	000				A					
28 1	908151-0200	PIN;STRAIGHT,CRANK CASE	2	000					A					
29	911258-1080	PACKING;OIL PAN-BRG.CASE	2	0000	000	00			A					@
30	909851-8260	SPACER;OIL FILLER	1	0	000	0			A					
35	511369-0850	NIPPLE;DRAIN OIL PAN	1	0	0				A				(-80-3)	

5

5-3

3AF1	3AE1	Engine Type
BBBBB	SBBBB	SSE
B	LLL	T OOB
	00	D 12 DD
	12	: 0
		: 1

Key No.	Part No.	Part Name	Per Unit									L	S · C	I T C	Remarks	NOT E
35	511369-0860	NIPPLE; DRAIN OIL PAN	1	0	:	0:	:	:	:	:	:	:	A	A		
37	109604-0150	PLUG; DRAIN NIPPLE	1	0	:	0:	:	:	:	:	:	:	A	A		
38	109623-0890	PACKING; O-RING	1	0	:	0:	:	:	:	:	:	:	A	A		
38	909561-2180	PACKING; O-RING	1	0	:	0:	:	:	:	:	:	:	A	A	(-80-3)	
40	509361-0360	HOSE; RUBBER OILPAN-NIPPLE	1	0	:	0:	:	:	:	:	:	:	A	A		
41	909915-5131	CLIP; HOSE	2	0	:	0:	:	:	:	:	:	:	A	A		

MEMO

OIL PUMP & FIXING PARTS

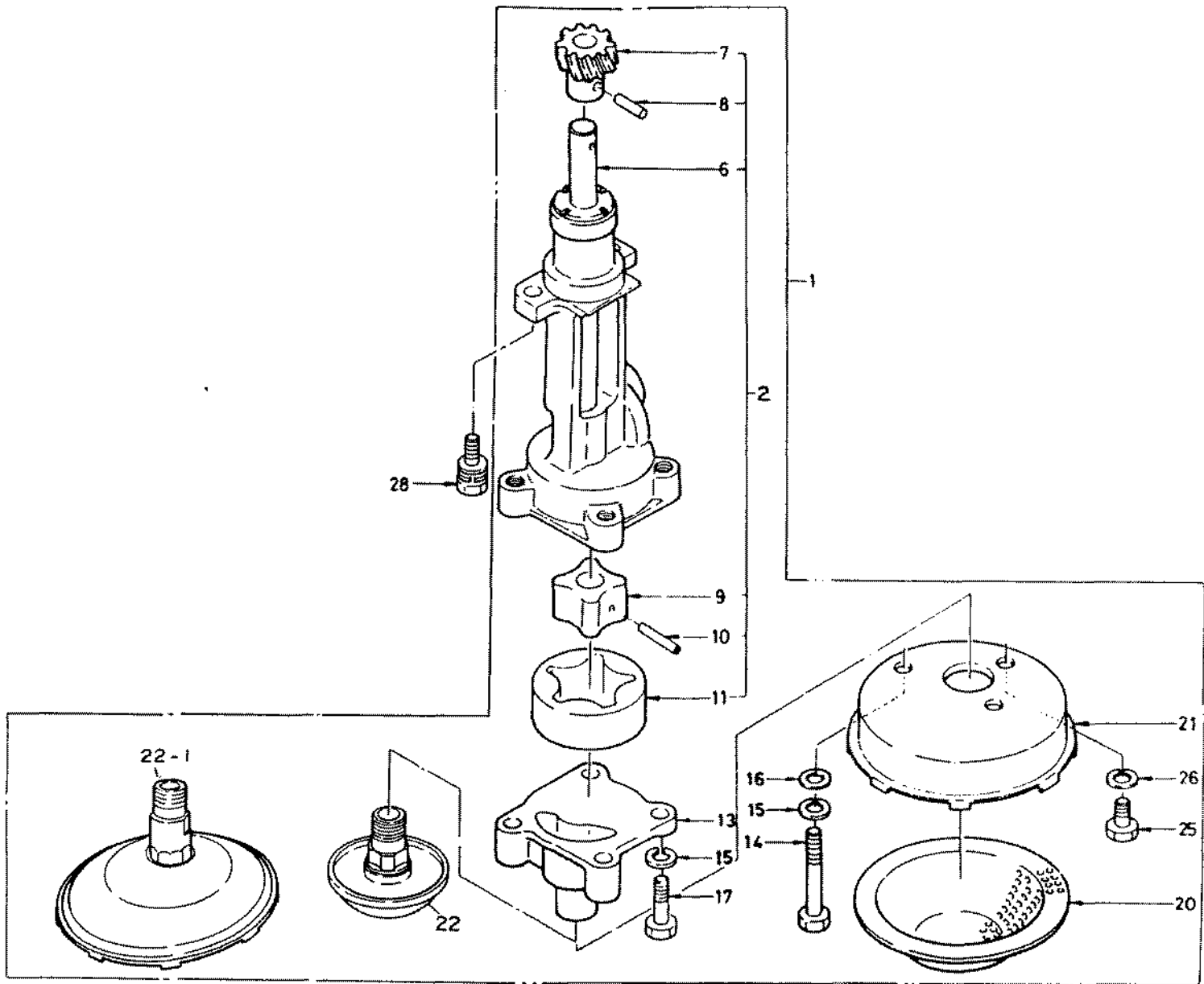

Key No.	Part No.	Part Name	Per Unit	3AF1		3AE1		Engine Type		L	S C	I T C	Remarks	NOTE
				BBBBB	SBBBB	SSE	LLL	T	OOB					
				12:	0		1							
1	913100-6150	PUMP ASM.; OIL, W/ STRAINER	1	0	000	00					A			
1	913100-6150	PUMP ASM.; OIL, W/ STRAINER	1	0	0	0					A		(-80-11)	
1	513100-1280	PUMP ASM.; OIL, W/ STRAINER	1	0	0	0:0					A	B		
1	513100-0940	PUMP ASM.; OIL, W/ STRAINER	1	000							A			
2	913120-6010	ROTOR SET;	1	00000	00000	000				1	F			
6	913123-1030	SHAFT; OIL, PUMP DRIVE	1	00000	00000	000				1	A			@
7	913128-0790	PINION; OIL, PUMP DRIVE	1	00000	00000	000				1	A			
8	909878-0840	PIN; PINION-SHAFT	1	00000	00000	000				1	A			
9	913121-0560	ROTOR; OIL PUMP	1	00000	00000	000				1	A			@
10	913129-0170	PIN; ROTER-SHAFT	1	00000	00000	000				1	A			@
11	913125-0470	VANE; OIL PUMP	1	00000	00000	000				1	A			@
13	913113-0860	COVER; OIL PUMP	1	0	0					1	A	D	(-81-11)	
13	913113-0860	COVER; OIL PUMP	1	0	000	00				1	A			
13	513113-0260	COVER; OIL PUMP	1	0	000	0 0:0				1	A			
14	901045-8500	BOLT; COVER FIX.	2	0	0	0:				1	A	D	(-80-11)	
14	901045-8500	BOLT; COVER FIX.	2	0	000	00				1	A			
15	909150-5080	WASHER; SPR.	4	0	0	0:0				1	A	D	(-80-11)	
15	909150-5080	WASHER; SPR.	4	0	000	00				1	A			
16	909164-5080	WASHER; PL.	2	0	0	0:				1	A	D	(-80-11)	
16	909164-5080	WASHER; PL.	2	0	000	0				1	A			
17	902040-8250	BOLT; COVER FIX.	2	0	0	0:00				1	A	D	(-80-11)	
17	902040-8250	BOLT; COVER FIX.	2	0	000					1	A			
17	901960-8250	BOLT; SEMS. COVER FIX.	4	0	000	0 0:0				1	A			
20	913143-6030	GAUZE; OIL STRAINER	1	0	0	0:00				1	A	D	(-80-11)	
20	913143-6030	GAUZE; OIL STRAINER	1	0	000					1	A			
21	913141-6041	CASE; OIL STRAINER	1	0	0	0:00				1	A	D	(-80-11)	
21	913141-6041	CASE; OIL STRAINER	1	0	000					1	A			
22	513140-0060	STRAINER ASM.; OIL	1	000						1	A			
22	513140-0090	STRAINER ASM.; OIL	1	0	0	0:0				1	A	E	(80-12-)	
25	902040-8120	BOLT; CASE FIX.	1	0	0	0:				1	A	D	(-80-11)	
25	902040-8120	BOLT; CASE FIX.	1	0	000	00				1	A			
26	909150-5080	WASHER; SPR.	1	0	0	0:				1	A		(-80-11)	
26	909150-5080	WASHER; SPR.	1	0	000	00				1	A			
28	901970-8250	BOLT; SEMS. OIL PUMP FIX.	2	00000	00000	000				1	A			

7

7-1

CRANK SHAFT, CRANK BRG., PISTON, CONN. ROD & FLY WHEEL

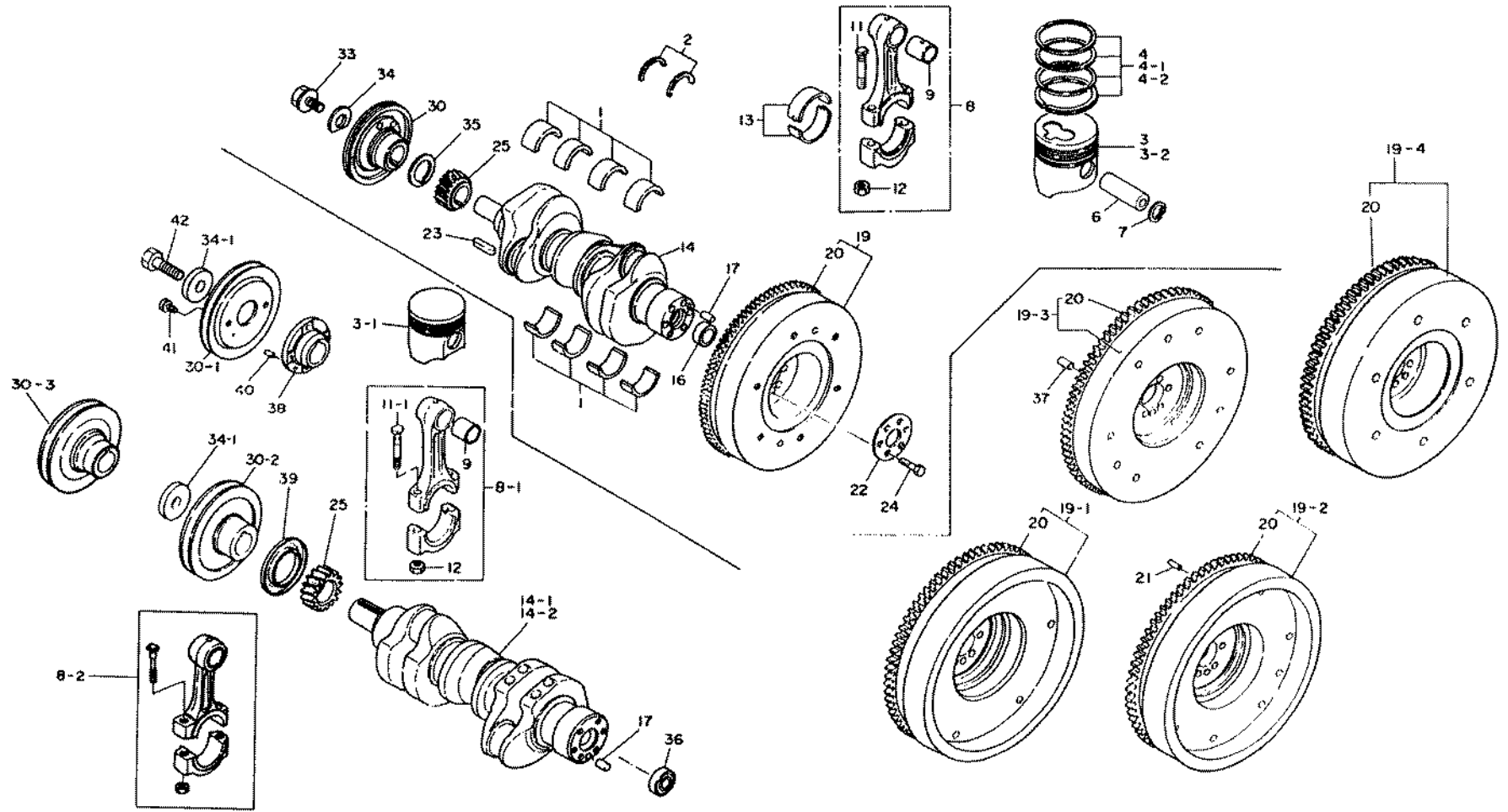

Key No.	Part No.	Part Name	Per Unit	3AF1		3AE1		Engine Type		L	S	I	T	C	Remarks	NOTE
				BBBBB	SBBBB	SSE	B	LLL	T							
				00:0	12	DD										
				12:	0											
					1											
1	511510-0330	BRG.KIT;CRANK.STD.	1	00000	00000	000										
1 1	511540-0330	BRG.KIT;CRANK.UNSI.0.50	1	00000	00000	000										
1 2	511560-0330	BRG.KIT;CRANK.UNSI.1.00	1	00000	00000	000										
2	911581-0570	BEARING;THRUST	2	00000	00000	000										
3	512111-1690	PISTON;STD.	3	00000	0											
3	512111-2450	PISTON;STD.	3	00000	0									A		
3 1	512111-1600	PISTON;STD.	3		0000									A		
3 1	512111-2310	PISTON;STD.	3		0000	000								A		(-80-12)
3	512114-1690	PISTON;OVSI.0.50	3	00000	0									A		
3	512114-2450	PISTON;OVSI.0.50	3	00000	0									A		
3 1	512114-1600	PISTON;OVSI.0.50	3		0000									A		(-80-12)
3 1	512114-2310	PISTON;OVSI.0.50	3		0000	000								A		(-80-12)
3	512116-1690	PISTON;OVSI.1.00	3	00000	0									A		
3	512116-2450	PISTON;OVSI.1.00	3	00000	0									A		
3 1	512116-1600	PISTON;OVSI.1.00	3		0000									A		(-80-12)
3 1	512116-2310	PISTON;OVSI.1.00	3		0000	000								A		(-80-12)
4	512121-0120	RING SET;PISTON.STD.	3	00000	0									A		
4	512121-0110	RING SET;PISTON.STD.	3		0000	000								A		
4 1	512124-0120	RING SET;PISTON.OVSI.0.50	3	00000	0									A		
4 1	512124-0110	RING SET;PISTON.OVSI.0.50	3		0000	000								A		
4 2	512126-0120	RING SET;PISTON.OVSI.1.00	3	00000	0									A		
4 2	512126-0110	RING SET;PISTON.OVSI.1.00	3		0000	000								A		
6	512211-0210	PIN;PISTON	3	00000	00000	000								A		
7	909950-1150	RING;SNAP	6	00000	00000	000								A		
8	512230-0500	ROD ASM.;CONN.	3	00000										A		(-81-2)
8	512230-0520	ROD ASM.;CONN.	3	00000	0									A		
8	512230-0580	ROD ASM.;CONN.	3	00000	0									A		
8 1	512230-0490	ROD ASM.;CONN.	3		0000									A		(-81-2)
8 1	512230-0491	ROD ASM.;CONN.	3		0000	0								A		
8 1	512230-0492	ROD ASM.;CONN.	3		0000	000								A		
9	512251-0070	BUSH;SMALL END	3	00000	00000	000								A		
11	512235-0080	BOLT;CONN.	6	00000	0									A		
11 1	912235-0680	BOLT;CONN.	6		0000	000								A		
12	909840-2380	NUT	6	00000	00000	000								A		
13	512271-0320	BEARING SET;CONN.	3	00000	0000									A		
13	894221-1670	BEARING SET;CONN.	3	00000	00000	000								A		
13	894110-9300	BEARING SET;CONN.	3	00000	00000	000								A		
13 1	894136-2490	BEARING;CONN.UNSI.0.25	3	00000	00000	000								A		
13 2	894136-2500	BEARING;CONN.UNSI.0.5	3	00000	00000	000								A		
14	512310-1110	CRANK SHAFT ASM.	1	0	0	0								A		
14 1	512310-1120	CRANK SHAFT ASM.	1	0	0000	0								A		
14 1	512310-1122	CRANK SHAFT ASM.	1	0	0000	00								A		
14 2	512310-1280	CRANK SHAFT ASM.	1	000										A		
14 2	512310-1282	CRANK SHAFT ASM.	1	000										A		
16	912319-0030	BUSH;CRANK SHAFT	1	0	0	0								A		
17	908151-2220	PIN;STRAIGHT	1	00000	00000	000								A		
19	512330-1290	FLYWHEEL ASM.	1	0	0									A		(-80-5)
19	512330-1291	FLYWHEEL ASM.	1	0	0									A		(-80-5)
19 1	512330-1531	FLYWHEEL ASM.	1		000									A		(-80-5)

Key No.	Part No.	Part Name	Per Unit	3AF1		3AE1		Engine Type		L	S-C	I T C	Remarks	NOTE
				BBBBB	SBBBB	SSE	B	LLL	T					
				00:D	12	DD								
				12:		0								
						1								
19 1	512330-1532	FLYWHEEL ASM. ;	1			000					A	A		
19 2	512330-1541	FLYWHEEL ASM. ;	1	0							A	A	(-80-5)	
19 2	512330-1542	FLYWHEEL ASM. ;	1	0							A	A		
19 3	512330-1442	FLYWHEEL ASM. ;	1	000							A	A	(-80-5)	
19 3	512330-1443	FLYWHEEL ASM. ;	1	000	0	0					A	A		
19 4	912330-6191	FLYWHEEL ASM. ;	1			00					A	A		
20	912333-0361	GEAR; RING	1	00000	00000	000					A	A		
21	909878-5320	PIN; STRAIGHT	1	0							A	A		
22	512336-0020	WASHER; FLYWHEEL FIX.	1	00000	00000	000					A	A		
23	908030-7430	KEY; FEATHER	1	00	00000	000					A	A		
23	908010-7400	KEY; FEATHER	1	000							A	A		
24	509000-0181	BOLT; FLYWHEEL	6	00000	00000	000					A	A		
25	512521-0280	GEAR; CRANK SHAFT	1	0	0	0:000					A	A		
25	512521-0181	GEAR; CRANK SHAFT	1	0000	000						A	A		
30	512371-2150	PULLEY; CRANK SHAFT	1	0		0:					A	A		
30 1	512371-2350	PULLEY; CRANK SHAFT	1	000							A	A	(-80-8)	
30 1	512371-2390	PULLEY; CRANK SHAFT	1	000							A	A		
30 2	512371-2160	PULLEY; CRANK SHAFT	1	0	000						A	A		
30 3	912373-6051	PULLEY; CRANK SHAFT	1			0					A	A		
33	909802-6060	BOLT; CRANK, PULLEY	1	00	00000	000					A	A		
34	912379-0160	WASHER; CRANK, PLULLEY	1	00	00000	000					A	A		
34 1	894200-7391	WASHER; CRANK, PLULLEY	1	000							A	A		
35	512379-0090	SPACER; CRANK, PLULLEY	1	0	0	0:0 0					A	A		
36	900090-6790	BRG.; BALL, FLYWHEEL	1	0000	0000	00					A	A		
37	908150-6140	PIN; STRAIGHT	3	000							A	A		
38	512371-1740	PULLEY BOSS; CRANK	1	000							A	A		
39	912373-6060	THROWER; DUST SEAL	1	0	000						A	A		
40	908160-5120	PIN;	1	000							A	A		
41	901910-8160	BOLT; SEMS	4	000							A	A		
42	901066-6450	BOLT; CRANK, PLULLEY	1	000							A	A		

MEMO

VALVE MECHANISM (CAM SHAFT, IDLE GEAR, ROCKER ARM)

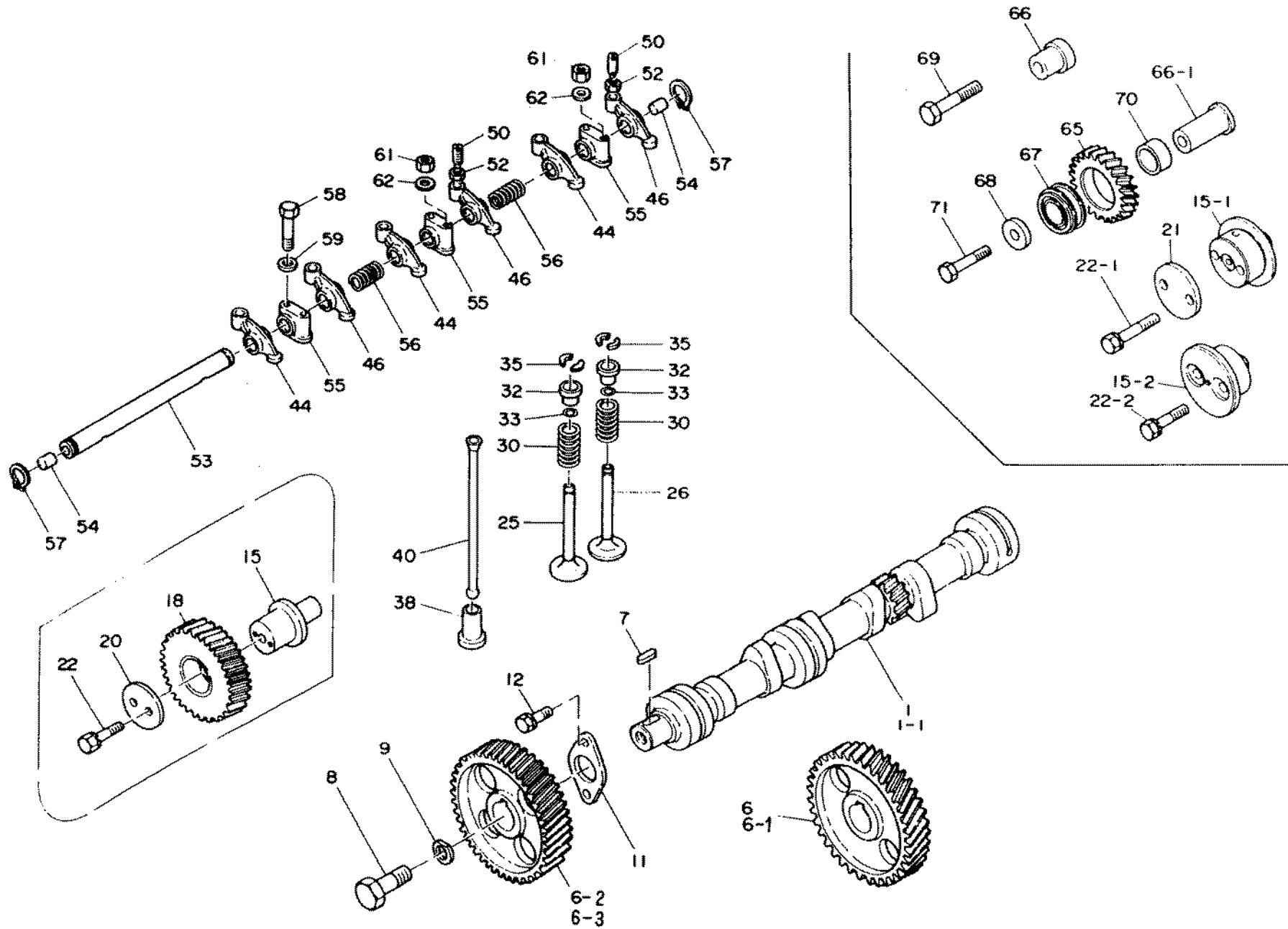

MEMO

Key No.	Part No.	Part Name	Per Unit	3 AF 1		3 AE 1		Engine Type		L	S C	I T C	Remarks	NOTE
				BBBBB	SBBBB	SSE	B	LLL	T					
				00	D	12	DD	12	0					
				0					1					
1	513200-1562	FILTER ASM.; OIL	1	0		0					A			
1 1	513200-1892	FILTER ASM.; OIL	1	0		0000	000				A			
1 2	513200-1960	FILTER ASM.; OIL	1			000:					A		(-80-8)	
1 2	513200-1962	FILTER ASM.; OIL	1			000:					A		(-81-2)	
1 2	513200-1965	FILTER ASM.; OIL	1			000:					A	C		
2	913240-8041	CARTRIDGE; OIL FILTER	1	00		00000	0 0			1	A			
2	513240-0410	CARTRIDGE; OIL FILTER	1	00		00000	000			1	A	C		
2 1	513240-0260	CARTRIDGE; OIL FILTER	1			000:				1	A			
2 1	513240-0420	CARTRIDGE; OIL FILTER	1			000:				1	A	C		
6	513210-0061	COVER ASM.; W/RELIEF VLV.	1	0			0:			1	A			
6 1	513210-0160	COVER ASM.; W/RELIEF VLV.	1	0		0000	000			1	A			
6 2	513210-0190	COVER ASM.; W/RELIEF VLV.	1			000:				1	A		(-80-8)	
6 2	513210-0192	COVER ASM.; W/RELIEF VLV.	1			000:				1	A	C	(-81-2)	
6 2	513210-0193	COVER ASM.; W/RELIEF VLV.	1			000:				1	A			
28	913160-0680	VALVE ASM.; RELIEF VLV.	1	00		00000	000			2	A			
28 1	513160-0030	VALVE ASM.; RELIEF VLV.	1			000:				2	A			
38	909920-5250	PACKING; O-RING	1	00		00000	000			3	A			
38 1	909920-9750	PACKING; O-RING	1			000:				3	A			
39	913263-0110	PLUG;	1	0		0000	0 0			2	A			
39	894132-6650	PLUG;	1	0		0000	000			2	A	A		
39 1	999205-5170	PLUG;	1			000:				2	A			
40	513260-0070	VALVE ASM.; SAFETY	1	0			0:			2	A			
45	513219-0140	PACKING; OIL FILTER-CYL.	1	00000		00000	000			2	A			@
45 1	909920-8410	PACKING; O-RING	1	0		0000	000			2	A			
46	909940-5820	SPRING	1	0		0000	000			2	A			
48	901900-8300	BOLT; SEMS. OIL FILTER	2	0			0:				A			
48 1	901900-8300	BOLT; SEMS. OIL FILTER	2	0000		0000	000				A			
48 2	901045-8750	BOLT; OIL FILTER	2			000:					A			
48 3	901900-8450	BOLT; SEMS. OIL FILTER	2	0			0:				A			
48 4	901045-8750	BOLT; OIL FILTER	1	0		0000	000				A			
48 5	901900-8450	BOLT; OIL FILTER	1	0		0000	000				A			
49	909150-5080	WASHER; SPR.	1	0		0000	000				A			
49 1	909150-5080	WASHER; SPR.	2			000:					A			
50	900097-0110	BALL; STEEL	1	0		0000	000			2	A			
60	513200-1380	FILTER ASM.; FUEL	1	0		0	0:000				A			
62	513211-0110	BODY; FUEL FILTER	1	0		0	0:000			1	A			
64	513212-0330	COVER; FUEL FILTER	1	0		0	0:000			1	A			
65	513213-0031	PACKING; BODY-COVER	1	0		0	0:000			1	A			@
67	913231-0750	BOLT; CENTER	1	0		0	0:000			1	A			@
70	509623-0060	PACKING; O-RING	1	0		0	0:000			1	A			@
72	913240-1100	ELEMENT ASM.;	1	0		0	0:000			1	A			@
74	509630-0080	PACKING; ELEMENT	2	0		0	0:000			1	A			@
76	909941-3000	SPRING; ELEMENT	1	0		0	0:000			1	A			
78	909857-0530	SEAT; SPR.	1	0		0	0:000			1	A			
80	909612-0210	SCREW	1	0		0	0:000			1	A			
82	909720-0260	PACKING	1	0			0:			1	A			
82	513219-0290	PACKING	1	0		0	0:000			1	A	C	(-81-4)	
85	901970-8220	BOLT; SEMS. COVER FIX.	2	0		0	0:000			1	A			

OIL PIPE & OTHER PARTS

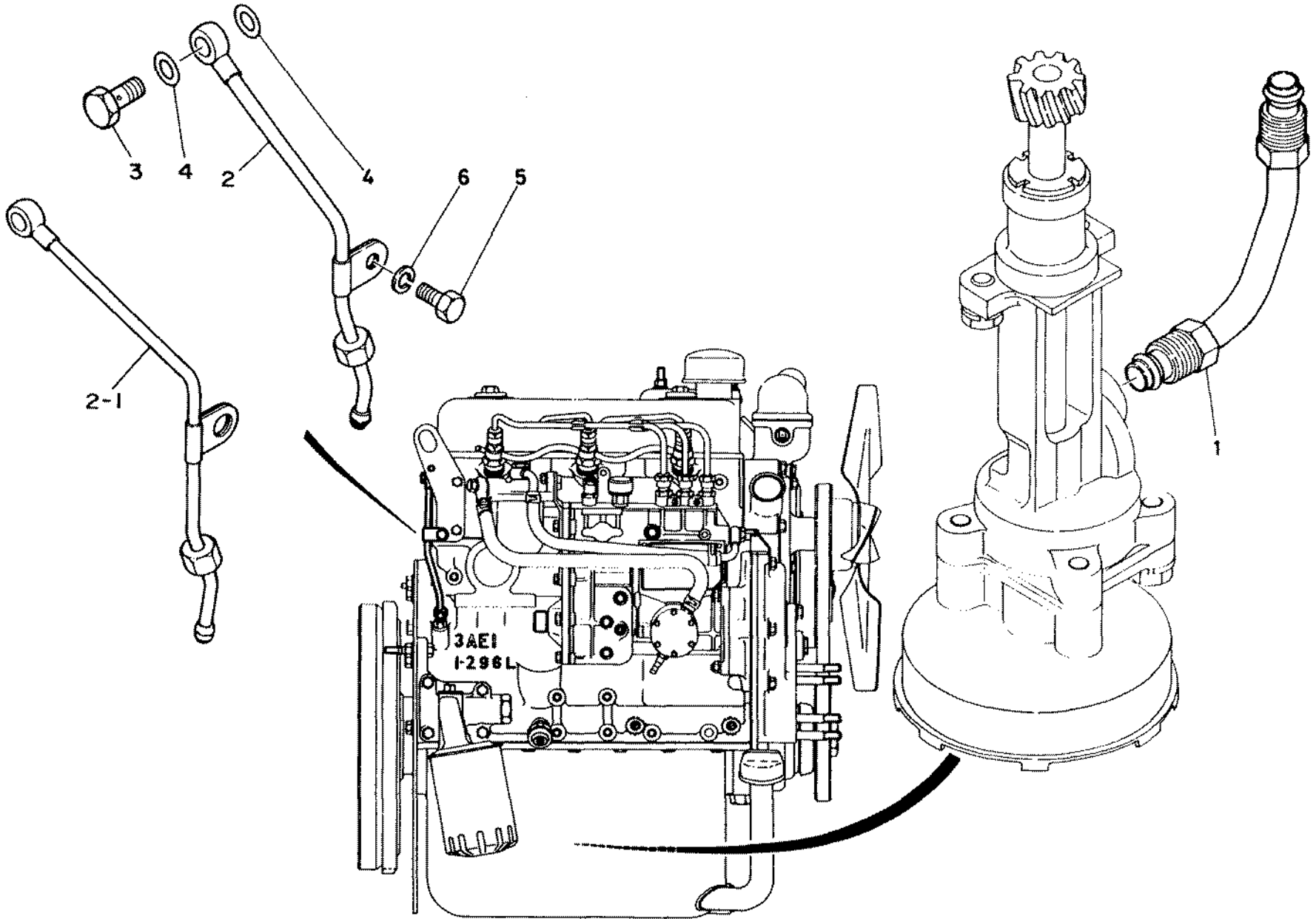

Key No.	Part No.	Part Name	Per Unit	3AF1		3AE1		Engine Type		L	S · C	I T C	Remarks	NOTE
				BBBBB	SBBBB	SSE	B	LLL	T					
				00000	00000	000	:	:	:	:	:	:		
				00	:	00000	000	:	:	:	:	:		
				000	:	:	:	:	:	:	:	:		
1	913312-3250	PIPE ASM.; OIL PUMP	1	00000	00000	000	:	:	:	:	:	:		
2	513310-1191	PIPE ASM.; OIL,ROCKER	1	00	:	00000	000	:	:	:	:	:		
2	513310-1410	PIPE ASM.; OIL,ROCKER	1	000	:	:	:	:	:	:	:	:		
3	909906-1051	BOLT; JOINT	1	00000	00000	000	:	:	:	:	:	:		
4	909920-9000	PACKING; JOINT BOLT	2	00000	00000	000	:	:	:	:	:	:		
5	902040-6100	BOLT;ROCKER ARM	1	00	:	00000	000	:	:	:	:	:		
6	909150-5060	WASHER; SPR.	1	00	:	00000	000	:	:	:	:	:		

COOLING SYSTEM (FAN, WATER & OIL)

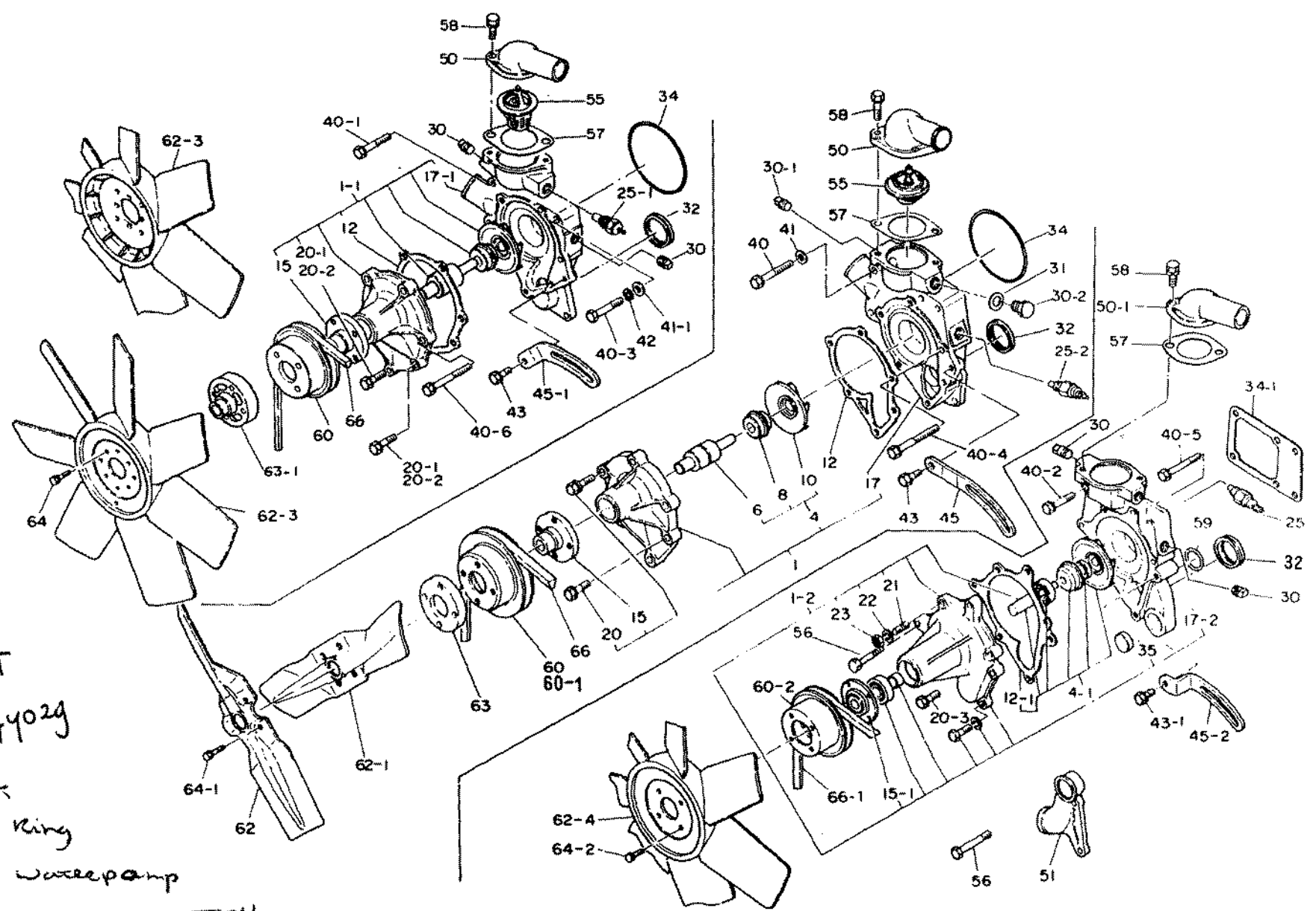

32 eot
62547402g

34. eus
packing ring
leadett waterpump

Johnny

Key No.	Part No.	Part Name	Per Unit	3 AF 1		3 AE 1		Engine Type		L	S	I	T	C	Remarks	NOTE
				BBBB	SBBBB	SSE	B	LLL	T							
				00:0	12:0	DD										
1	513610-1390	PUMP ASM.; WATER, W/ THERMO	1	0	0	0					A				(-80-4)	
1	513610-1392	PUMP ASM.; WATER, W/ THERMO	1	0	0	0					A				(-80-12)	
1	513610-1393	PUMP ASM.; WATER, W/ THERMO	1	0	0	0:0					A					
1	513610-2070	PUMP ASM.; WATER, W/ THERMO	1	0	0	0:000					A					
1	513610-1410	PUMP ASM.; WATER, W/ THERMO	1	0	0	000					A				(-80-4)	
1	513610-1412	PUMP ASM.; WATER, W/ THERMO	1	0	0	000					A				(-80-12)	
1	513610-1413	PUMP ASM.; WATER, W/ THERMO	1	0	0	000					A					
1	513610-1531	PUMP ASM.; WATER, W/ THERMO	1	000							A				(-80-5)	
1	513610-1802	PUMP ASM.; WATER, W/ THERMO	1	000							A				(-80-8)	
1	513610-1890	PUMP ASM.; WATER, W/ THERMO	1	000							A				(-81-3)	
1	2	513610-1891	PUMP ASM.; WATER, W/ THERMO	1	000						A					
4	894211-4390	REPAIR KIT; WATER PUMP	1	00	00000	0				1	F					
4	1	587810-2050	REPAIR KIT; WATER PUMP *	1	000	0				1	F					
6		N.P.N	BEARING; WATER PUMP	1	00	00000	0	0		2	Z					
8		N.P.N	SEAL SET; WATER PUMP	1	00	00000	0	0		2	Z					
10		N.P.N	ROTOR; WATER PUMP	1	00	00000	0	0		2	Z					
12		894202-4810	GASKET; WATER PUMP	1	00	00000	000			1	A					
12	1	513613-0090	GASKET; WATER PUMP *	1	000					1	A					
15		513642-0470	CENTER; FAN, WATER PUMP	1	00	0000				1	A					
15		513642-0471	CENTER; FAN, WATER PUMP	1	00	00000	000			1	A					
15	1	513642-0540	CENTER; FAN, WATER PUMP	1	000					1	A					
17		513612-0130	COVER; WATER PUMP	1	0	0				1	A				(-80-4)	
17		513612-0132	COVER; WATER PUMP	1	0	0	0:0			1	A					
17		513612-0250	COVER; WATER PUMP	1	0	0	0:000			1	A					
17	1	513612-0140	COVER; WATER PUMP	1	0	000				1	A				(-80-4)	
17	1	513612-0142	COVER; WATER PUMP	1	0	000				1	A					
17	2	513612-0151	COVER; WATER PUMP	1	000					1	A				(-80-5)	
17	2	513612-0171	COVER; WATER PUMP	1	000					1	A				(-80-9)	
17	2	513612-0190	COVER; WATER PUMP	1	000					1	A				(-81-3)	
17	2	513612-0191	COVER; WATER PUMP	1	000					1	A					
20		901970-8300	BOLT; WATER PUMP FIX.	5	0	0	0:000			1	A					
20	1	901910-8300	BOLT; WATER PUMP FIX.	3	0	000				1	A					
20	2	509030-0190	BOLT	1	0	000				1	A					
20	3	901900-8220	BOLT	3	000					1	A					
21		904100-8200	STUD	1	000					1	A					
22		909150-5080	WASHER; SPR.	1	000					1	A				(-81-3)	
23		909110-4080	NUT	1	000					1	A				(-81-3)	
25		582450-0140	SWITCH; OVER HEAT	1	000	0				1	A					
25	1	582450-0180	THERMOMETER UNIT	1	0	000				1	A					
25	2	582450-0200	SWITCH; OVER HEAT	1	0	0				1	A					
25	3	983151-4320	THERMOMETER UNIT	1		0					A					
30		909204-5170	PLUG; 3/8 HEATER	2	0000	0000	0	0			A					
30	1	909204-5170	PLUG; 3/8 HEATER	1	0	0					A					
30	2	909661-0050	PLUG; THERMOMETER	1	0	0	0:0	0			A					
31		909571-3160	PACKING; PLUG	1	0	0	0:0	0			A					
32		513619-0982	PACKING; PUMP-CYL. BLOCK	1	00000	00000	000				A					
34		509623-0310	PACKING; PUMP-CYL. HEAD	1	00	00000	0				A					
34		513743-0190	PACKING; PUMP-CYL. HEAD	1	00	00000	000				A					
34	1	513743-0190	PACKING; PUMP-CYL. HEAD	1	000						A					
35		511129-0050	GUID TUBE; WATER PIPE	1	000						A					

Key No.	Part No.	Part Name	Per Unit	3AF1		3AE1		Engine Type		L	S · C	I T C	Remarks	NOTE
				88888: S8888: SSE	B LLL: T 008: TT	00: D 12: DD	12: 0	1						
40	509000-0840	BOLT; SEMS	4	0	0	0	0	0	0		A			
40 1	901970-8450	BOLT; SEMS	2	0	000						A			
40 2	901900-8450	BOLT; SEMS	1		000						A		(-81-2)	
40 2	901910-8450	BOLT; SEMS	1		000						A			
40 3	901055-8500	BOLT;	1	0	000						A		(-80-7)	
40 3	509030-0370	BOLT;	1	0	000						A			
40 4	894205-9870	BOLT; SEMS	1	0	0	0	0	0	0		A			
40 5	509000-0840	BOLT; SEMS	2		000						A			
40 6	894205-9860	BOLT;	2		0000	000					A			
41	909160-5080	WASHER; PL.	3	0	0	0	0	0	0		A			
41 1	909160-5080	WASHER; PL.	1	0	000						A			
42	909150-5080	WASHER; SPR.	1	0	000						A			
43	901910-8220	BOLT; SEMS, ADJ. -PUMP	1	00	00000	000					A			
43 1	901910-8320	BOLT; SEMS, ADJ. -PUMP	1		000						A			
45	513674-0630	PLATE; ADJ. FAN BELT	1	0		0	0				A			
45	513674-0860	PLATE; ADJ. FAN BELT	1		0	0	0	0			A			
45 1	513674-0710	PLATE; ADJ. FAN BELT	1	0	000						A		(-80-5)	
45 1	513674-0830	PLATE; ADJ. FAN BELT	1	0	000						A			
45 2	513674-0750	PLATE; ADJ. FAN BELT	1		000						A		(-80-5)	
45 2	513674-0840	PLATE; ADJ. FAN BELT	1		000						A			
50	913713-0641	PIPE ASM.; WATER OUTLET	1	00	0000	00					A			
50 1	913713-0780	PIPE ASM.; WATER OUTLET	1		000						A			
51	513711-0081	PIPE ASM.; WATER	1		000						A		(-81-1)	
51	513711-0082	PIPE ASM.; WATER	1		000						A			
55	513770-0220	THERMOSTAT;	1	00	00000	0					A		(-80-1)	
55	513770-0221	THERMOSTAT;	1	00	00000	000					A			
56	901055-8600	BOLT;	2		000						A		(-80-3)	
56	509000-1580	BOLT;	2		000						A			
57	509637-0130	PACKING; OUTLET PIPE	1	00000	00000	000					A			
58	901910-8280	BOLT; SEMS, OUTLET PIPE	2	00000	00000	000					A			
59	509623-0420	PACKING; COVER-WATER PIPE	1		000						A			
60	913641-6090	PULLEY; COOLING FAN	1	0	00000	0					A			
60 1	913641-1250	PULLEY; COOLING FAN	1	0		0					A			
60 2	513641-0300	PULLEY; COOLING FAN	1		000						A			
60 3	513641-0420	PULLEY; COOLING FAN	1			0					A			
62	513662-0100	BLADE; UPPER, COOLING FAN	1	0							A			
62	513662-0100	BLADE; UPPER, COOLING FAN	1			0					A		(-81-2)	
62	913662-1442	BLADE; UPPER, COOLING FAN	1		0	0	0	0			A			
62 1	513662-0110	BLADE; LOWER, COOLING FAN	1	0							A		(-81-2)	
62 1	513662-0110	BLADE; LOWER, COOLING FAN	1			0					A			
62 1	913662-1451	BLADE; LOWER, COOLING FAN	1		0	0	0	0			A			
62 3	513660-2970	FAN ASM.	1	0	000						A		(-80-2)	
62 4	513660-2710	FAN ASM.	1		000						A			
62 4	513660-2711	FAN ASM.;	1		000						A			
62 5	513660-3110	FAN ASM.;	1			0					A			
63	913642-0760	SPACER; FAN	1	0		0					A		(-80-2)	
63	913642-0761	SPACER; FAN	1	0	0	0	0	0	0		A			
63 1	989136-4230	SPACER; FAN	1	0	000	0					A			
63 2	513642-0770	SPACER; FAN	1			0					A			
64	901910-6350	BOLT; SEMS	4	0	000						A			

Key No.	Part No.	Part Name	Per Unit	3 AF 1		3 AE 1		Engine Type		L	S · C	I T C	Remarks	NOTE
				BBBBB	SBBBB	SSE	B	LLL	T					
64 1	901910-6250	BOLT:SEMS	4	0		0	0							
64 2	901910-6120	BOLT:SEMS	4	000										
64 3	901910-6200	BOLT:SEMS	4		0									
64 4	509000-1580	BOLT:SEMS	4			0								
66	513671-0400	BELT:COOLING FAN	1	00		0000								
66	913671-8080	BELT:COOLING FAN	1		0		00							
66 1	513671-0920	BELT:COOLING FAN	1	000										
66 1	513671-1380	BELT:COOLING FAN	1	000										
66 2	913671-8090	BOLT:COOLING FAN	1				0							

(-80-11)

AIR INTAKE & EXHAUST SYSTEM

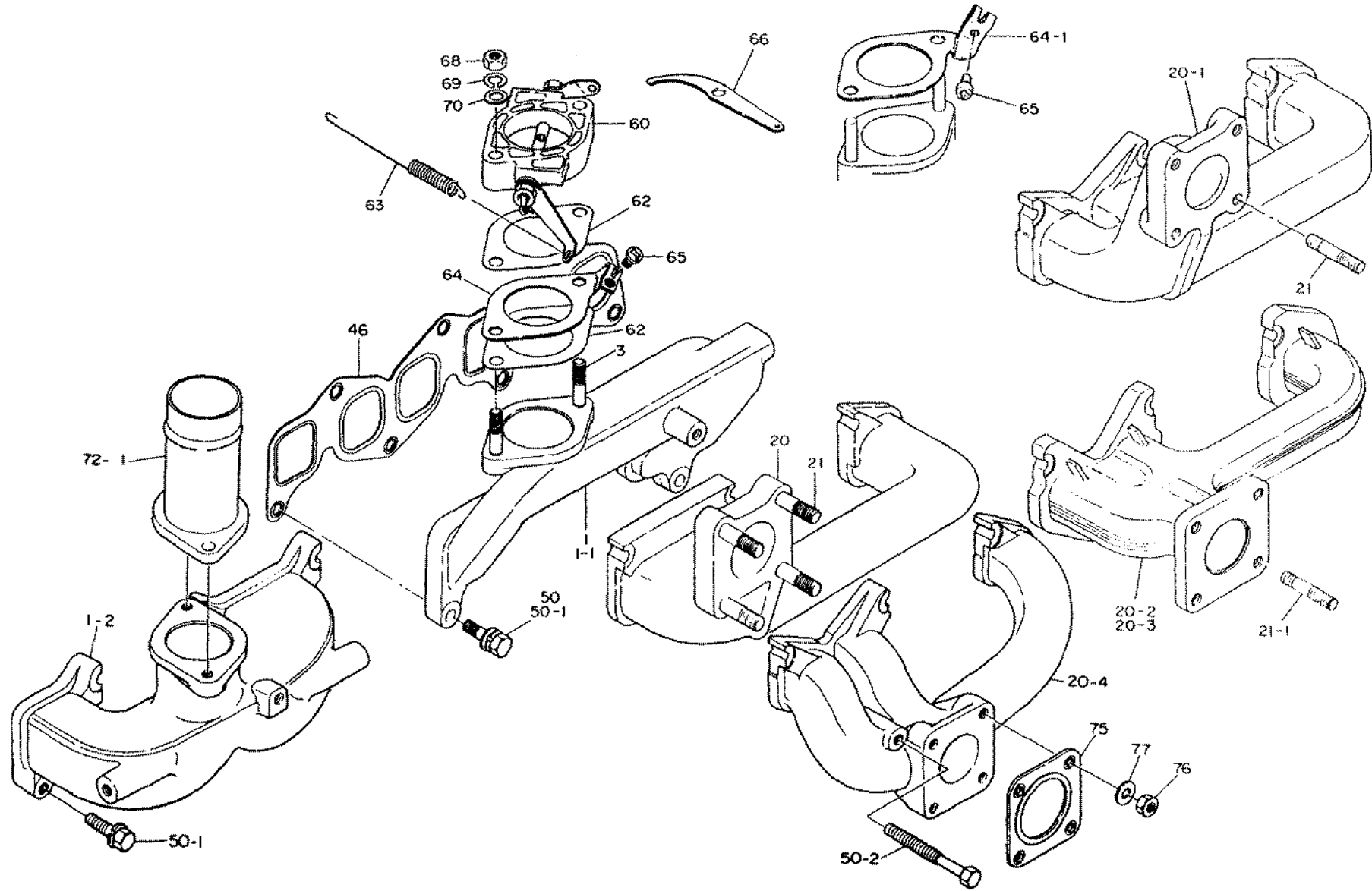

Key No.	Part No.	Part Name	Per Unit	3AF1		3AE1		Engine Type		L	S C	I T C	Remarks	NOTE
				BBBBB	SBBBB	SSE	B	LLL	T					
1	514111-2180	MANIFOLD; INLET	1	00	00000	0					A			
1 1	514111-1982	MANIFOLD; INLET	1	000							A		(-80-6)	
1 1	514111-1983	MANIFOLD; INLET	1	000							A			
1 2	914112-6551	MANIFOLD; INLET	1			00					A			
3	904100-8480	STUD	2	00	0000	0					A			
20	514141-0800	MANIFOLD; EXH.	1	0		0					A			
20 1	514141-0630	MANIFOLD; EXH.	1	0	000						A			
20 2	514141-0860	MANIFOLD; EXH.	1	000							A		(-80-4)	
20 2	514141-0861	MANIFOLD; EXH.	1	000	0	0					A			
20 3	514141-0060	MANIFOLD; EXH.	1			00					A			
21	909630-0200	STUD	4	0	000						A			
21 1	904110-8220	STUD	4	0		0	00				A			
21 2	904110-8250	STUD	4	000							A		(-80-3)	
21 2	904111 0250	STUD	4	000		0					A			
46	914146-0900	GASKET; INLET, EXH. MANI.	1	00000	00000	000					A			⊗
50	901960-8320	BOLT	7	00000	00000	0					A			
50 1	901960-8350	BOLT	6			00					A			
50 2	901045-8950	BOLT	1			00					A			
60	514310-2743	SHUTTER ASM.; INTAKE	1	00	0000						A			
60 1	914310-4191	SHUTTER ASM.; INTAKE	1			0					A			
62	509637-0150	PACKING; SHUTTER	3	00	0000						A			⊗
62 1	509637-0150	PACKING; SHUTTER	2			0					A			
63	909742-0630	SPRING; SHUTTER, RETURN	1	00	0000						A			
63 1	909942-6000	SPRING; SHUTTER, RETURN	1			0					A			
64	514319-1000	CLIP; SHUTTER, RETURN	1	0		0					A			
64 1	514319-3180	CLIP; SHUTTER	1	0	000						A			
64 2	914319-6260	CLIP; SHUTTER	1			0					A			
65	909812-0210	BOLT	1	00	0000						A			
65 1	902040-6100	BOLT	1			0					A			
66	514319-3140	EYE; SPRING, SHUTTER	1	00	0000						A			
66 1	514334-0010	EYE; SPRING, SHUTTER	1			0					A			
68	909110-4080	NUT	2	00	0000	0					A			
69	909150-5080	WASHER; SPR.	2	00	0000						A			
69 1	909150-5060	WASHER; SPR.	1			0					A			
70	909164-5080	WASHER; PL.	2	00	0000						A			
72	914112-6970	PIPE; INLET	1		0	0					A			
72 1	514111-1350	PIPE; INLET	1			0					A			
72 2	514111-0850	PIPE; INLET	1			0					A			
73	509637-0150	PACKING; INLET-MANIF.	1		0	000					A			
74	901900-8200	BOLT; SEMS, INLET PIPE	2		0	0 0					A			
75	914145-8020	GASKET; EXH. PIPE	1			0					A			
76	909640-0190	NUT	4			0					A			
77	909164-5080	WASHER; PL.	4			0					A			

IR CLEAR & OTHER PARTS

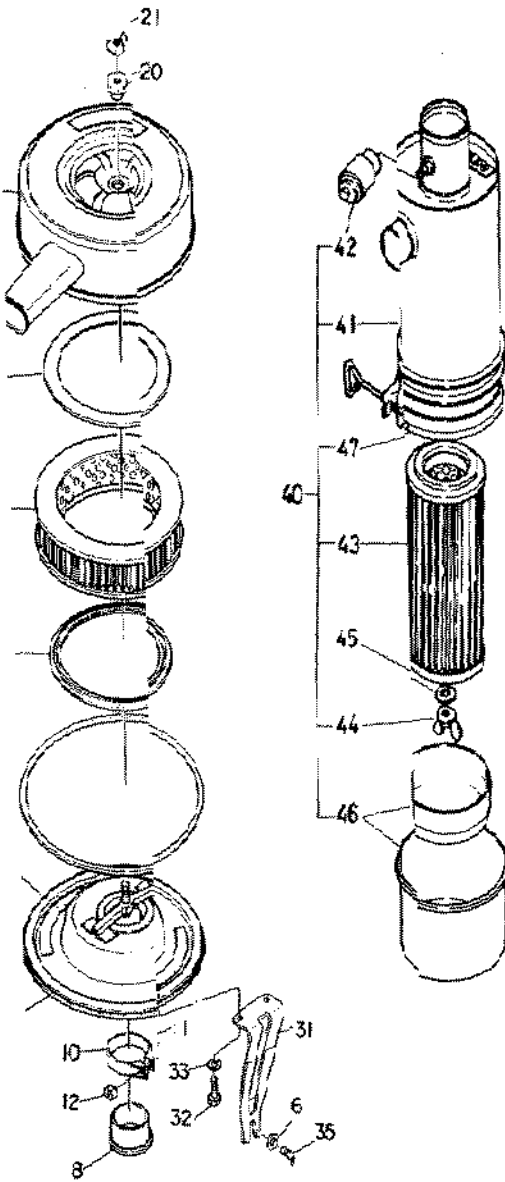

Key No.	Part No.	Part Name	Per Unit	3 AF 1		3 AE 1		Engine Type		L	S · C	I T C	Remarks	NOTE
				BBBBB:SBBBB:SSE	B LLL:T OOB:TT	00:D 12 :DD	12: 0	1						
	914210-6031	CLEANER ASM.:AIR	1		0						A			
5	514211-1110	BODY ASM.:AIR CLENER	1		0					1	A			
6	914213-6140	PACKING;ELEMENT	1		0					1	A			
7	914213-6130	PACKING;COVER	1		0					1	A			
8	914239-0280	INSULATOR	1		0					1	A			
10	514217-0100	BAND;INSULATOR	1		0					1	A			
11	903470-6250	BOLT	1		0					1	A			
12	909110-4060	NUT	1		0					1	A			
15	914215-6040	ELEMENT ASM.:AIR CLENER	1		0					1	A			
17	514212-0750	COVER ASM.:	1		0					1	A			
18	914213-6140	PACKING;FILMENT	1		0					1	A			
20	514239-0700	PACKING ASM.;WING NUI	1		0					1	A			
21	914217-0790	NUT;WING	1		0					1	A			
30	914234-6020	BRACKET;FRONT,AIR CLENER	1		0						A			
31	914234-6030	BRACKET;REAR,AIR CLENER	1		0						A			
32	902050-6120	BOLT;BRKT.-AIR CLENER	4		0						A			
33	909150-5060	WASHER;SPR.	4		0						A			
35	901910-8140	BOLT;BRKT.-MANIFOLD	2		0						A			
36	909164-5080	WASHER;PL.	2		0						A			
40	514210-0490	CLEANER ASM.:AIR	1		0						A			
41	514211-0130	BODY ASM.:AIR	1		0					1	A			
42	914219-1410	INDICATOR;SERVICE	1		0					1	A			
43	514215-0021	ELEMENT ASM.	1		0					1	A			
44	514217-0010	NUT ASM.	1		0					1	A			
45	514219-0020	WASHER;GASKET	1		0					1	A			
46	514212-0110	BAFFLE ASM.;CUP	1		0					1	A			
47	514217-0020	CLAMP ASM.	1		0					1	A			

FUEL SYSTEM (INJ. NOZZLE, FUEL PIPE)

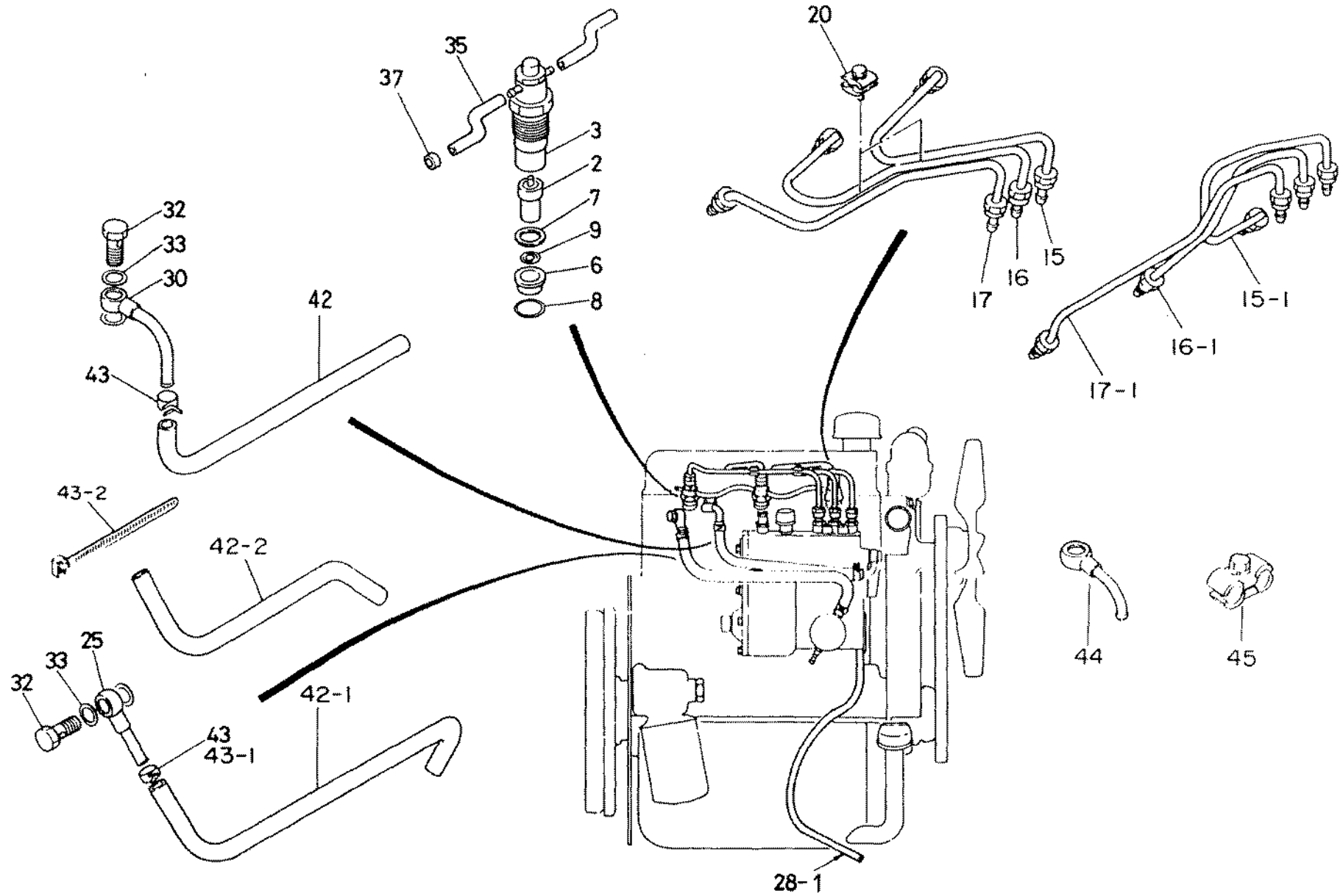

Key No.	Part No.	Part Name	Per Unit	3 AF 1		3 AE 1		Engine Type		L	S - C	I T C	Remarks	NOTE
				BBBBB	SBBBB	SSE	B LLL	T OOB	TT					
2	515311-0220	NOZZLE; FUEL, INJ.	3	00000	00000						A		(-80-1)	
2	515311-0180	NOZZLE; FUEL, INJ.	3	00000	00000	000					A			
3	515330-0160	HOLDER ASM.; NOZZLE, FIG. 58	3	00000	00000						B		(-80-7)	
3	515330-0161	HOLDER ASM.; NOZZLE, FIG. 58	3	00000	00000	000					B			
6	915315-0270	HEAT SHIELD; NOZZLE	3	00000	00000	000					B			
7	915315-0260	WASHER; NOZZLE HOLDER	3	00000	00000	000					A			
8	915315-0280	WASHER; HEAT SHIELD	3	00000	00000	000					A			
9	915315-0740	WASHER; CORRUGATED	3	00000	00000	000					A			
15	515411-5761	PIPE ASM.; INJ. NO. 1	1	0	0	0	000				A			
15	515411-7370	PIPE ASM.; INJ. NO. 1	1	00000	000						A		(-80-4)	
15	515411-8090	PIPE ASM.; INJ. NO. 1	1	00000	000						A			
16	515411-5771	PIPE ASM.; INJ. NO. 2	1	0	0	0	000				A			
16	515411-7380	PIPE ASM.; INJ. NO. 2	1	00000	000						A		(-80-4)	
16	515411-8100	PIPE ASM.; INJ. NO. 2	1	00000	000						A		(-80-6)	
16	515411-8101	PIPE ASM.; INJ. NO. 2	1	00000	000						A			
17	515411-5781	PIPE ASM.; INJ. NO. 3	1	0	0	0	000				A			
17	515411-7391	PIPE ASM.; INJ. NO. 3	1	00000	000						A		(-80-4)	
17	515411-8110	PIPE ASM.; INJ. NO. 3	1	00000	000						A			
20	915419-0720	CLIP ASM.	2	00000	00000	000					A			
25	509674-0151	PIPE ASM.; INJ. PUMP-FILTER	1	0	0						A		(-80-7)	
25	515411-8220	PIPE ASM.; INJ. PUMP-FILTER	1	0	0	0	000				A			
28	909913-8460	PIPE; VINYL, INJ. LEAKE OFF	1	0	0	0	000				A			
28	909913-8490	PIPE; VINYL, INJ. LEAKE OFF	1	0	000						A			
28	909913-5250	PIPE; VINYL, INJ. LEAKE OFF	1	0	000						A			
30	515411-5660	PIPE ASM.; FILTER-INJ.	1	0	0						A		(-80-7)	
30	515411-8230	PIPE ASM.; FILTER-INJ.	1	0	0	0	000				A			
32	109675-0810	BOLT; JOINT, FUEL FILTER	2	0	0	0	000				A			
33	909571-4120	PACKING; JOINT BOLT	4	0	0						A		(-80-7)	
33	909572-0120	PACKING; JOINT BOLT	4	0	0	0	000				A			
35	509360-9121	HOSE; RUBBER, NOZZLE LEAKE	1	00000	00000	0	0				A			
37	515419-0140	CAP; RUBBER NOZZLE LEAKE	1	00000	00000	000					A			
42	509361-0600	HOSE; RUBBER	1	0	0						A		(-81-7)	
42	509360-7220	HOSE; RUBBER	1	0	000						A		(-80-4)	
42	509361-0741	HOSE; RUBBER	1	0	000						A			
42	509360-7230	HOSE; RUBBER	1	0	0						A		(-80-7)	
43	909715-0540	CLIP; HOSE	4	0	0						A		(-80-12)	
43	509704-0590	CLIP; HOSE	4	00000	00000	000					A			
43	894205-5611	CLIP; HOSE	2	0	000						A		(-80-4)	
43	509707-0041	CLIP; HOSE	2	0	000						A			
43	509707-0360	CLIP; HOSE	1	00000	00000	0	0				A			
43	909915-1630	CLIP; NOZZLE LEAKE OFF	1	00000	00000	000					A			
44	515411-8120	PIPE ASM; FUEL INJ. PUMP	1	0	000						A			
45	509700-2250	CLIP ASM; FUEL PIPE	1	0	0	0	000				A			

ENGINE FOOT, HANGER & FIXING PARTS

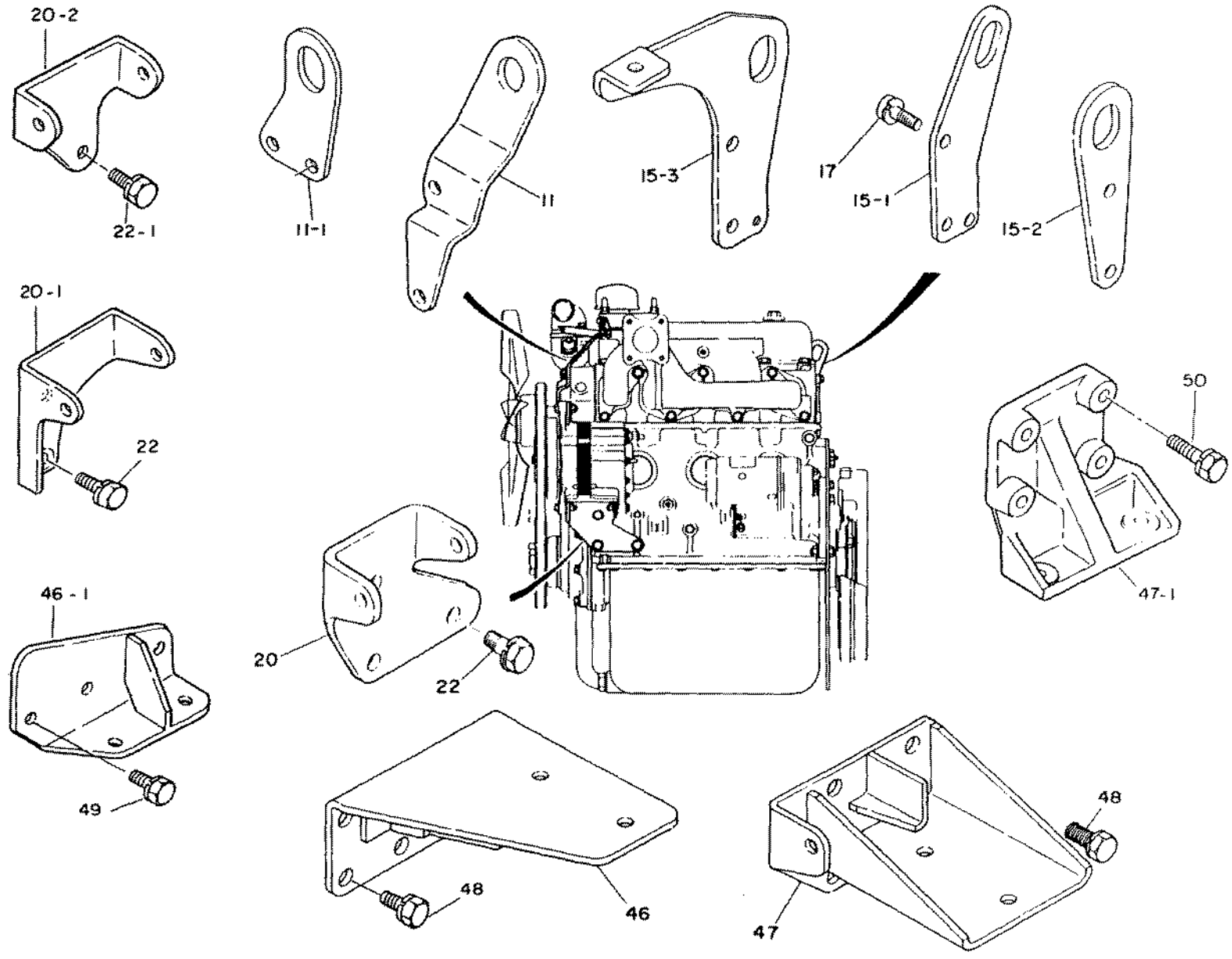

Key No.	Part No.	Part Name	Per Unit	3 AF 1		3 AE 1		Engine Type		L	S C	I T C	Remarks	NOTE	
				BBBBB	SBBBB	SSE	B	LLL	T						OOB
11	511777-0320	HANGER; FRONT	1	00	00000	000					A				
11 1	511777-0440	HANGER; FRONT	1	000							A				
15 1	511777-0330	HANGER; REAR	1	0	0	0	0	0			A				
15 2	511777-0590	HANGER; REAR	1	0	000						A				
15 3	511777-0450	HANGER; REAR	1	000							A				
17	901910-8180	BOLT; SEMS. HANGER FIX.	2	00000	00000	000					A				
20	519711-0721	BRACKET; GENERATOR	1	0	000						A		(-80-5)		
20	519711-0980	BRACKET; GENERATOR	1	0	000						A	B	(-80-7)		
20 1	519711-0760	BRACKET; GENERATOR	1	000							A	B	(-80-10)		
20 1	519711-0970	BRACKET; GENERATOR	1	000							A	B			
20 1	519711-0971	BRACKET; GENERATOR	1	000							A	A			
20 2	519711-1010	BRACKET; GENERATOR	1	0	0	0					A				
20 3	519711-0770	BRACKET; GENERATOR	1	0							A				
22	901911-0200	BOLT; SEMS. BRKT. FIX.	2	0000	000						A				
22 1	901911-0400	BOLT; SEMS. BRKT. ENG. FOOT	2	0	0	00					A				
22 2	901911-0220	BOLT; SEMS. BRKT.	2	0		0					A				
46	511771-1350	FOOT; ENG. FRT. RH	1	0	0						A				
46 1	511771-1470	FOOT; ENG. FRT. RH	1	0	0						A				
47	511771-1360	FOOT; ENG. FRT. LH	1	0	0						A				
47 1	511771-0501	FOOT; ENG. FRT. LH	1	0	0						A				
48	901911-0200	BOLT; SEMS. FRT.	8	0	0						A				
49	901911-0300	BOLT; SEMS. RH	4	0	0						A				
50	901911-0400	BOLT; SEMS. LH	1	0	0						A				
50	901911-0250	BOLT; SEMS. LH	1	0	0						A				

INJECTION PUMP & OTHER PARTS

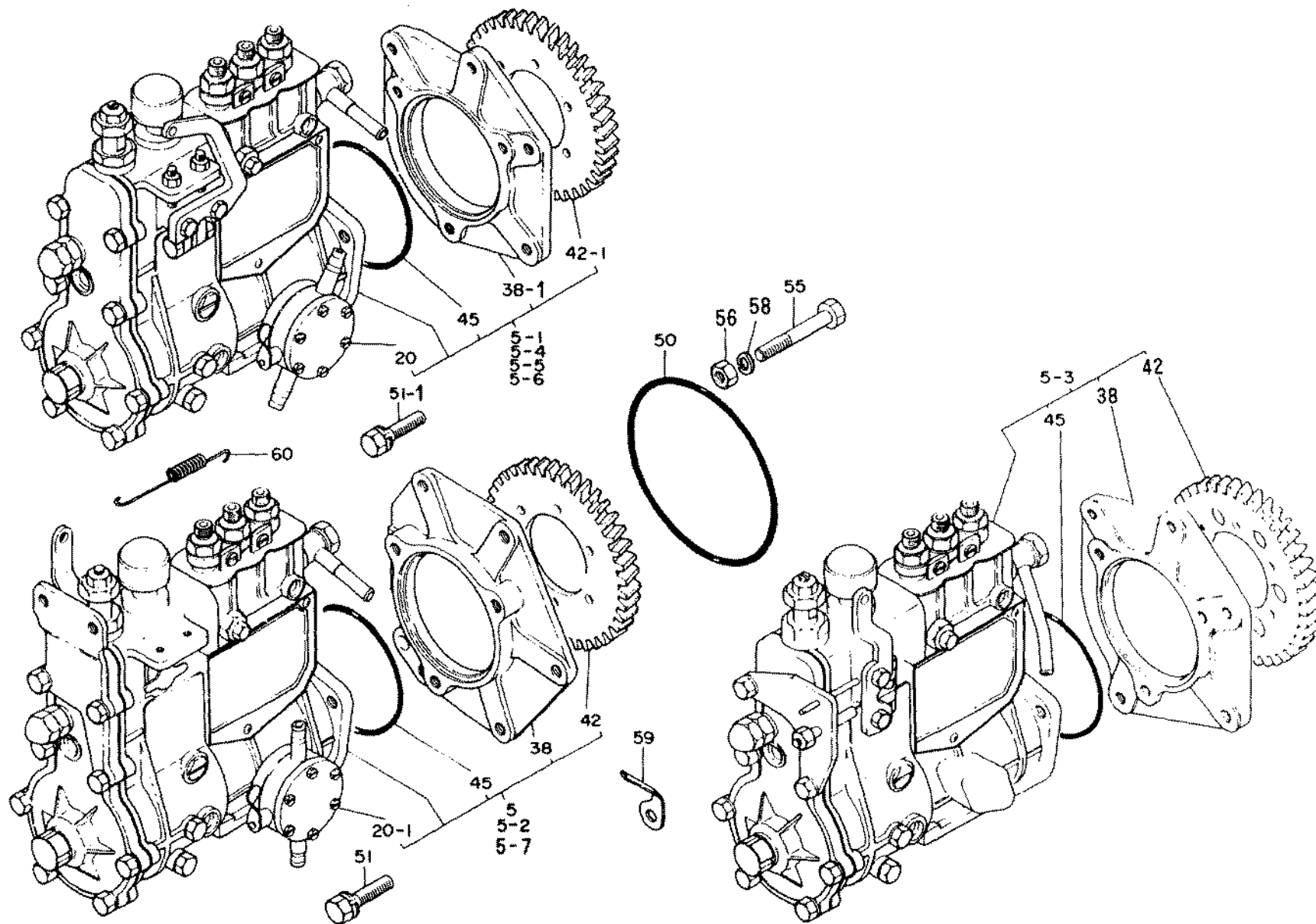

ELECTRICAL PARTS

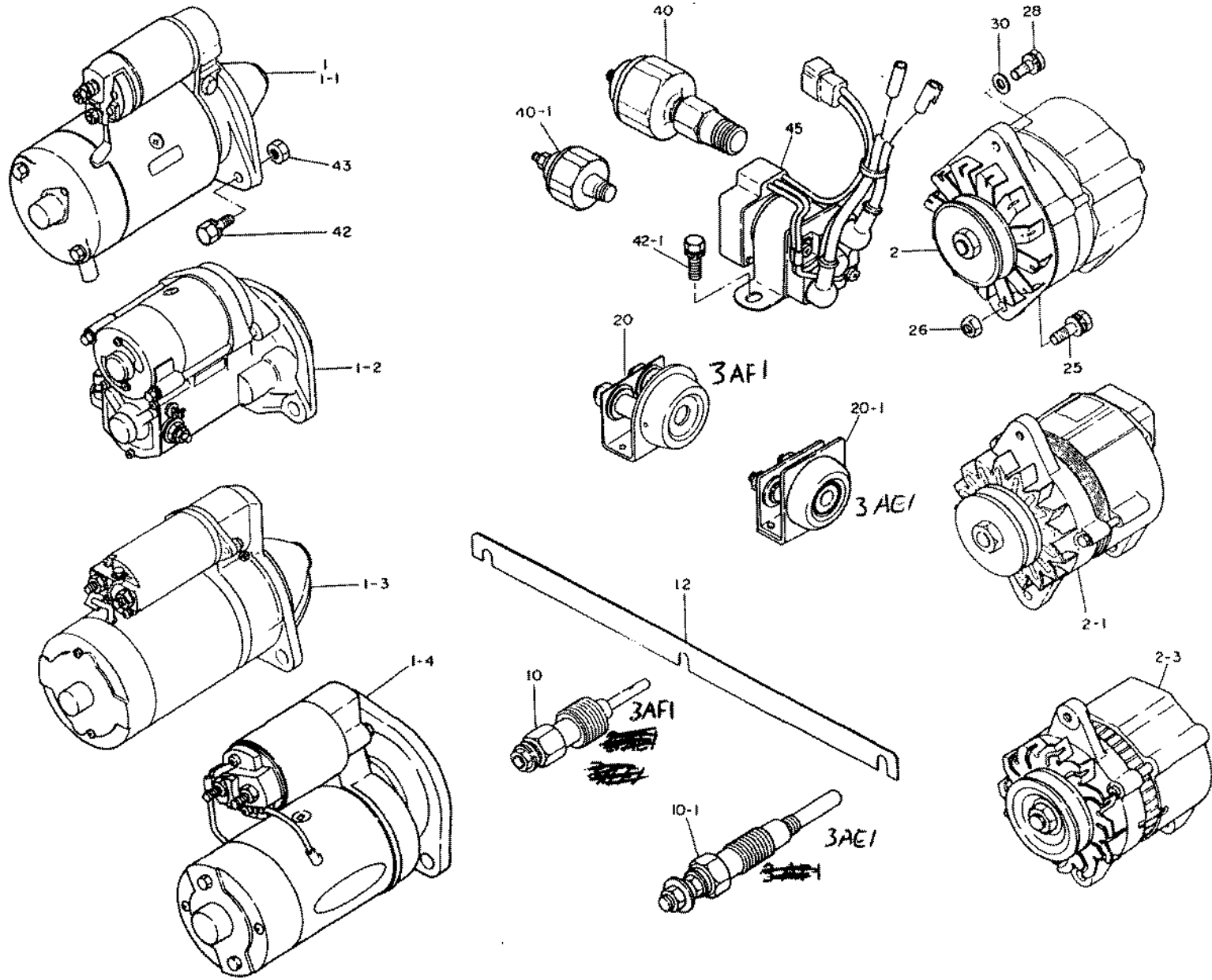

Key No.	Part No.	Part Name	Per Unit	3AF1		3AE1		Engine Type		L	S • C	I T C	Remarks	NOTE
				BBBBB	SBBBB	SSE	B	LLL	T					
				00:D	12	DD	0	1						
1	581100-0860	STARTER ASM.; FIG. 62	1	0	0						B			
1 2	581100-1650	STARTER ASM.; FIG. 62C	1	000							B		(-80-7)	
1 2	581100-1800	STARTER ASM.; FIG. 62D	1	000							B	B		
1 2	581100-2050	STARTER ASM.; FIG. 62F	1	000							B	C		
1 3	581100-1232	STARTER ASM.; FIG. 62B	1	0	0000						B			
1 3	581100-2050	STARTER ASM.; FIG. 62F	1	0	0000	0					B	C		
1 4	581100-2100	STARTER ASM.; FIG. 62E	1			00					B			
2	581200-3040	GENERATOR ASM.; FIG. 63	1	0	0						B		(-80-7)	
2	581200-3042	GENERATOR ASM.; FIG. 63	1	0	0000	0					B	A		
2 1	581200-2210	GENERATOR ASM.; FIG. 63B	1	0							B		(-80-5)	
2 1	581200-3000	GENERATOR ASM.; FIG. 63C	1	0	0	0					B	B		
2 1	581200-3381	GENERATOR ASM.; FIG. 63	1	0							B			
2 2	581200-3200	GENERATOR ASM.; FIG. 63C	1	000							B			
2 2	581200-3490	GENERATOR ASM.; FIG. 63	1	000							B	C		
2 3	581200-3410	GENERATOR ASM.; FIG. 63E	1			0					B			
10	581410-0490	PLUG; GLOW, SHEATHED TYPE	3	00000	0000						A		(-80-10)	
10	581410-0610	PLUG; GLOW, SHEATHED TYPE	3	00000	00000	0					A	C	(-82-5)	
10 1	581410-0690	PLUG; GLOW, SHEATHED TYPE	3	00000	00000	000					A	B		
12	919732-0750	CONNECTOR	1	00000	00000	000					A			
20	581420-0110	RESISTANCE	1	0	0						A			
20	581420-0370	RESISTANCE 3AF1	1	00000	0000						A		(-81-2)	
20 1	581420-0410	RESISTANCE	1			00					A	C		
25	901970-8350	BOLT; SEMS, GENERATOR	2	00000	0000						A		(-80-12)	
25	901055-8350	BOLT; GENERATOR	2	00000	00000	000					A	B		
26	909110-5080	NUT; GENERATOR	2	00000	00000	000					A			
27	909150-5080	WASHER; SPR.	2	00000	00000	000					A		(81-1-)	
28	901910-8250	BOLT; SEMS, ADJ. PLATE	1	00000	0000						A	E	(-81-2)	
28	901910-8220	BOLT; SEMS, ADJ. PLATE	1	00000	00000	000					A	A		
29	901960-5080	WASHER; PL.	2	00000	00000	000					A	E	(81-1-)	
30	909164-7080	WASHER; PL.	1	00000	00000	000					A			
40	582410-0121	SWITCH; PRESSURE, WARNING	1	000							A		(-80-5)	
40	582410-0121	SWITCH; PRESSURE, WARNING	1	0	0						A	D		
40 1	182410-0081	SWITCH; PRESSURE, WARNING	1	0000	0000	000					A			
42	901931-2400	BOLT; STARTER FIX.	2	00000	00000	00					A			
42 1	901931-2350	BOLT; STARTER FIX.	2			0					A			
43	909120-4120	NUT; STARTER FIX.	2	00000	00000	00					A			
43 1	909111-4080	NUT; STARTER FIX.	1	0	0000						A			
45	582553-0671	SAFETY RELAY; STARTER	1			00					A			
46	182310-0060	SWITCH; STARTER	1			0					A			

完材品の内容部品

COMPLETE PARTS

MEMO

3

2

4

5

6

7

8

INJECTION PUMP; PROPER (DIESEL KIKI)

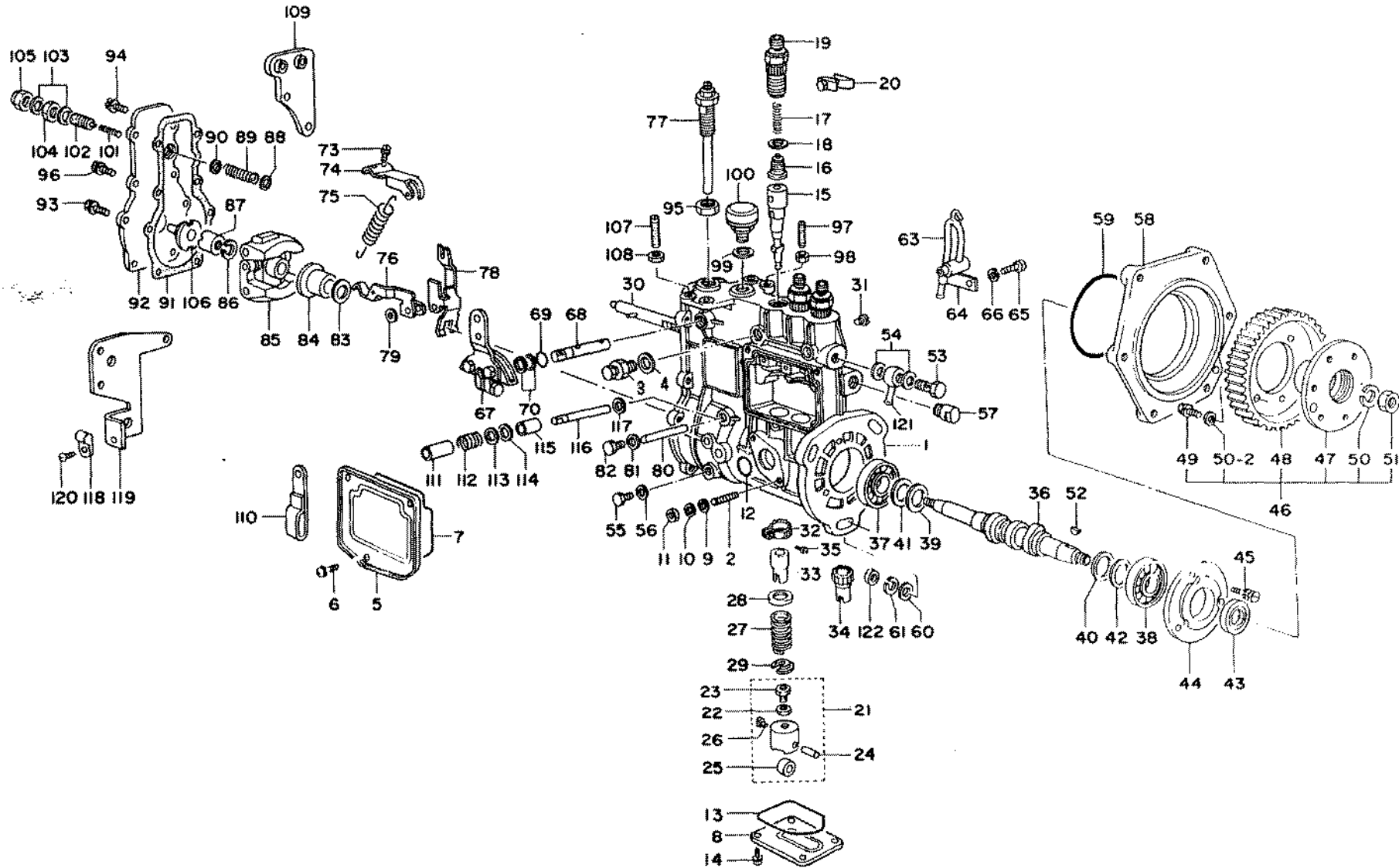

Key No.	Part No.	Part Name	Per Unit	INJ.PUMP;(DIESEL KIKI)							L	S C	I T C	Remarks	NOTE
				00000:00001:11111:11112:22222:22223:	:	:	:	:	:	:					
17	981241-3030	SPRING	3	00000:00000:00	:	:	:	:	:	:	1	A			
18	515639-0030	GASKET	3	00000:00000:00	:	:	:	:	:	:	1	A			
19	981241-4160	HOLDER; DELIVERY	3	00000:00000:00	:	:	:	:	:	:	1	A			
20	515619-0990	PLATE	2	00000:00000:00	:	:	:	:	:	:	1	A			
21	981221-2430	TAPPET ASM.	3	00000:00000:00	:	:	:	:	:	:	1	A			
22	515629-0060	NUT	3	00000:00000:00	:	:	:	:	:	:	2	A			
23	515629-0070	BOLT	3	00000:00000:00	:	:	:	:	:	:	2	A			
24	981221-2440	PIN	3	00000:00000:00	:	:	:	:	:	:	2	A			
25	981351-4030	ROLLER	3	00000:00000:00	:	:	:	:	:	:	2	A			
26	981221-2460	GUIDE	3	00000:00000:00	:	:	:	:	:	:	2	A			
27	981241-3070	SPRING; PLUNGER	3	00000:00000:00	:	:	:	:	:	:	1	A			
28	515639-0040	SEAT; SPRING	3	00000:00000:00	:	:	:	:	:	:	1	A			
29	981245-0250	SEAT; SPRING	3	00000:00000:00	:	:	:	:	:	:	1	A			
30	515637-0080	RACK; CONTROL	1	000:00000:00	:	:	:	:	:	:	1	A			
30 1	981233-7010	RACK; CONTROL	1	00:	:	:	:	:	:	:	1	A			
31	115639-0030	SCREW	1	00000:00000:00	:	:	:	:	:	:	1	A			
32	515636-0010	PINION	2	00000:00000:00	:	:	:	:	:	:	1	A			
33	515635-0010	SLEEVE; CONTROL	2	00000:00000:00	:	:	:	:	:	:	1	A			
34	515635-0020	SLEEVE; CONTROL	1	00000:00000:00	:	:	:	:	:	:	1	A			
35	981235-0030	SCREW	1	00000:00000:00	:	:	:	:	:	:	1	A			
36	515621-0270	CAM SHAFT	1	0	:	:	:	:	:	:	1	A	D (-81-2)		
36	515621-0270	CAM SHAFT	1	0	:	:	:	:	:	:	1	A			
36 1	515621-0280	CAM SHAFT	1	0000:0	:	:	:	:	:	:	1	A			
36 2	515621-0320	CAM SHAFT	1	00	:	:	:	:	:	:	1	A			
36 3	515621-0310	CAM SHAFT	1	0 0:00	:	:	:	:	:	:	1	A			
37	900090-0660	BEARING	1	00000:00000:00	:	:	:	:	:	:	1	A			
38	900090-2330	BEARING	1	00000:00000:00	:	:	:	:	:	:	1	A			
39	981225-0670	RING	1	00000:00000:00	:	:	:	:	:	:	1	A			
40	515629-0220	RING	1	00000:00000:00	:	:	:	:	:	:	1	A			
41	515629-0150	SHIM	A/R	00000:00000:00	:	:	:	:	:	:	1	A			
41 1	515629-0160	SHIM	A/R	00000:00000:00	:	:	:	:	:	:	1	A			
41 2	515629-0170	SHIM	A/R	00000:00000:00	:	:	:	:	:	:	1	A			
41 3	515629-0180	SHIM	A/R	00000:00000:00	:	:	:	:	:	:	1	A			
41 4	515629-0190	SHIM	A/R	00000:00000:00	:	:	:	:	:	:	1	A			
41 5	515629-0200	SHIM	A/R	00000:00000:00	:	:	:	:	:	:	1	A			
41 6	515619-0380	SHIM	A/R	00000:00000:00	:	:	:	:	:	:	1	A			
41 7	515629-0210	SHIM	A/R	00000:00000:00	:	:	:	:	:	:	1	A			
41 8	515619-0390	SHIM	A/R	00000:00000:00	:	:	:	:	:	:	1	A			
41 9	115619-0900	SHIM	A/R	00000:00000:00	:	:	:	:	:	:	1	A			
41 10	515619-0390	SHIM	A/R	0:	:	:	:	:	:	:	1	A			
42	515629-0150	SHIM	A/R	00000:00000:00	:	:	:	:	:	:	1	A			
42 1	515629-0160	SHIM	A/R	00000:00000:00	:	:	:	:	:	:	1	A			
42 2	515629-0170	SHIM	A/R	00000:00000:00	:	:	:	:	:	:	1	A			
42 3	515629-0180	SHIM	A/R	00000:00000:00	:	:	:	:	:	:	1	A			
42 4	515629-0190	SHIM	A/R	00000:00000:00	:	:	:	:	:	:	1	A			
42 5	515629-0200	SHIM	A/R	00000:00000:00	:	:	:	:	:	:	1	A			
42 6	515619-0380	SHIM	A/R	00000:00000:00	:	:	:	:	:	:	1	A			
42 7	515629-0210	SHIM	A/R	00000:00000:00	:	:	:	:	:	:	1	A			
42 8	515619-0390	SHIM	A/R	00000:00000:00	:	:	:	:	:	:	1	A			
42 9	115619-0900	SHIM	A/R	00000:00000:00	:	:	:	:	:	:	1	A			

Key No.	Part No.	Part Name	Per Unit	INJ. PUMP; (DIESEL KIKI)										L	S C	I T C	Remarks	NOT I
				00000:00001:11111:11112:22222:22223:	:	:	:	:	:	:	:	:	:					
77 1	515729-2210	CAPSULE; SPRING	1	00	:	:	:	:	:	:	:	:	:	:	1	A		
77 2	515729-1630	CAPSULE; SPRING	1	00	:	:	:	:	:	:	:	:	:	:	1	A		
77 3	515619-0700	CAPSULE; SPRING	1		:	:	:	:	:	:	:	:	:	:	1	A		
78	515725-0540	LEVER; GUIDE	1	00000:00000:00	:	:	:	:	:	:	:	:	:	:	1	A		
79	515729-1290	SPACER	1	00000:00000:00	:	:	:	:	:	:	:	:	:	:	1	A		
80	515729-1300	PIN	1	00000:00 0:00	:	:	:	:	:	:	:	:	:	:	1	A		
81	115639-0090	GASKET	2	00000:00 0:00	:	:	:	:	:	:	:	:	:	:	1	A		
82	515729-1320	PLUG	2	00000:00 0:00	:	:	:	:	:	:	:	:	:	:	1	A		
83	515729-1340	SHIM	A/R	00000:00000:00	:	:	:	:	:	:	:	:	:	:	1	A		
83 1	515729-1350	SHIM	A/R	00000:00000:00	:	:	:	:	:	:	:	:	:	:	1	A		
83 2	981393-3010	SHIM	A/R	00000:00000:00	:	:	:	:	:	:	:	:	:	:	1	A		
83 3	515729-1370	SHIM	A/R	00000:00000:00	:	:	:	:	:	:	:	:	:	:	1	A		
83 4	981393-3020	SHIM	A/R	00000:00000:00	:	:	:	:	:	:	:	:	:	:	1	A		
83 5	981393-3030	SHIM	A/R	00000:00000:00	:	:	:	:	:	:	:	:	:	:	1	A		
83 6	981393-3040	SHIM	A/R	00000:00000:00	:	:	:	:	:	:	:	:	:	:	1	A		
83 7	981393-3050	SHIM	A/R	00000:00000:00	:	:	:	:	:	:	:	:	:	:	1	A		
84	515729-1420	SLEEVE	1	00000:00000:00	:	:	:	:	:	:	:	:	:	:	1	A		
85	515722-0100	FLYWEIGHT ASM	1	00000:00000:00	:	:	:	:	:	:	:	:	:	:	1	A		
86	909150-5080	WASHER; SPR.	1	:0	:	:	:	:	:	:	:	:	:	:	1	A	D	(-81-2)
86	909150-5080	WASHER; SPR	1	00000: 000	:	:	:	:	:	:	:	:	:	:	1	A		
86 1	515629-0350	WASHER	1	:0 0:00	:	:	:	:	:	:	:	:	:	:	1	A		
87	515729-1430	NUT	1	:0	:	:	:	:	:	:	:	:	:	:	1	A		
87	515729-1430	NUT	1	00000: 000	:	:	:	:	:	:	:	:	:	:	1	A		
87 1	515629-0360	NUT	1	:0 0:00	:	:	:	:	:	:	:	:	:	:	1	A		
88	515729-1440	SEAT; SPRING	1	00000:00000:00	:	:	:	:	:	:	:	:	:	:	1	A		
89	515619-0660	SPRING	1	0 00:00 0:00	:	:	:	:	:	:	:	:	:	:	1	A		
89 1	515619-1130	SPRING	1	0 0: 00	:	:	:	:	:	:	:	:	:	:	1	A		
90	981391-3010	WASHER	A/R	00000:00000:00	:	:	:	:	:	:	:	:	:	:	1	A		
90 1	981391-3020	WASHER	A/R	00000:00000:00	:	:	:	:	:	:	:	:	:	:	1	A		
90 2	981393-3060	SHIM	A/R	00000:00000:00	:	:	:	:	:	:	:	:	:	:	1	A		
90 3	981393-3070	SHIM	A/R	00000:00000:00	:	:	:	:	:	:	:	:	:	:	1	A		
91	515619-0230	GASKET	1	00000:00000:00	:	:	:	:	:	:	:	:	:	:	1	A		
92	515721-0280	COVER	1	00000:00000:00	:	:	:	:	:	:	:	:	:	:	1	A		
93	515729-0580	BOLT	5	00000:00 0:00	:	:	:	:	:	:	:	:	:	:	1	A		
93 1	515729-0580	BOLT	4	00	:	:	:	:	:	:	:	:	:	:	1	A		
94	515729-1670	BOLT	1	00000:00000:00	:	:	:	:	:	:	:	:	:	:	1	A		
95	515729-1510	NUT; LOCK	1	00000:00000:00	:	:	:	:	:	:	:	:	:	:	1	A		
96	515729-2030	BOLT	2	0 :0 000:00	:	:	:	:	:	:	:	:	:	:	1	A		
97	515729-1520	SCREW	1	0 :0 0:00	:	:	:	:	:	:	:	:	:	:	1	A		
97 1	515619-1140	SCREW	1	00: 0	:	:	:	:	:	:	:	:	:	:	1	A		
97 2	515729-0440	SCREW	1	:00	:	:	:	:	:	:	:	:	:	:	1	A		
98	981325-0810	NUT	1	00000:00000:00	:	:	:	:	:	:	:	:	:	:	1	A		
99	115639-0080	GASKET	1	00000:00000:00	:	:	:	:	:	:	:	:	:	:	1	A		
100	515729-1000	BREATHER ASM; AIR	1	00000:00000:00	:	:	:	:	:	:	:	:	:	:	1	A		
101	515619-0680	SPRING	1	0 :0 0:00	:	:	:	:	:	:	:	:	:	:	1	A		
101 1	515619-1150	SPRING	1	0000: 000	:	:	:	:	:	:	:	:	:	:	1	A		
102	515619-0690	GUIDE SCREW	1	00000:00000:00	:	:	:	:	:	:	:	:	:	:	1	A		
103	981393-9070	GASKET	2	00000:00000:00	:	:	:	:	:	:	:	:	:	:	1	A		
104	981393-2040	NUT	1	00000:00000:00	:	:	:	:	:	:	:	:	:	:	1	A		
105	981325-1120	CAP NUT	1	00000:00000:00	:	:	:	:	:	:	:	:	:	:	1	A		

Key No.	Part No.	Part Name	Per Unit	INJ. PUMP; (DIESEL KIKI)												L	S • C	I T C	Remarks	NOTE
				00000:00001:11111:11112:22222:22223:	:	:	:	:	:	:	:	:	:	:	:					
106	515729-1090	SHAFT	1	00000:00000:00	:	:	:	:	:	:	:	:	:	1	A					
107	515729-1520	SCREW	1	0 : 0 : 0	:	:	:	:	:	:	:	:	:	1	A					
107	1 515619-1140	SCREW	1	0000: 0	:	:	:	:	:	:	:	:	:	1	A					
107	2 981393-9090	CAPSULE; SPR.	1	000:0	:	:	:	:	:	:	:	:	:	1	A					
108	981325-0810	NUT	1	00000:00	:	:	:	:	:	:	:	:	:	1	A					
108	1 981315-1810	NUT	1	000:00	:	:	:	:	:	:	:	:	:	1	A					
109	515729-2040	BRACKET	1	00000:00	:	:	:	:	:	:	:	:	:	1	A					
110	515725-1080	LEVER	1	00	:	:	:	:	:	:	:	:	:	1	A					
111	515729-2330	COLLAR	1	00	:	:	:	:	:	:	:	:	:	1	A					
112	515723-1390	SPRING	1	00	:	:	:	:	:	:	:	:	:	1	A					
113	981391-3110	WASHER	1	00	:	:	:	:	:	:	:	:	:	1	A					
114	515619-0240	SEAL; OIL	1	00	:	:	:	:	:	:	:	:	:	1	A					
115	515729-2340	COLLAR	1	00	:	:	:	:	:	:	:	:	:	1	A					
116	515729-2300	SHAFT	1	00	:	:	:	:	:	:	:	:	:	1	A					
117	515729-2350	WASHER	1	00	:	:	:	:	:	:	:	:	:	1	A					
118	515729-2360	PIN; SPLIT	1	00	:	:	:	:	:	:	:	:	:	1	A					
119	515729-2370	BRACKET	1	00	:	:	:	:	:	:	:	:	:	1	A					
119	1 515729-2040	BRACKET	1	0 0:0	:	:	:	:	:	:	:	:	:	1	A					
120	515729-2320	BOLT	1	00	:	:	:	:	:	:	:	:	:	1	A					
121	981393-9010	PIPE	1	00	:	:	:	:	:	:	:	:	:	1	A					
122	115729-2360	NUT	3	00000:00000:0	:	:	:	:	:	:	:	:	:	1	A					

FEED PUMP;INJECTION PUMP (DIESEL KIKI)

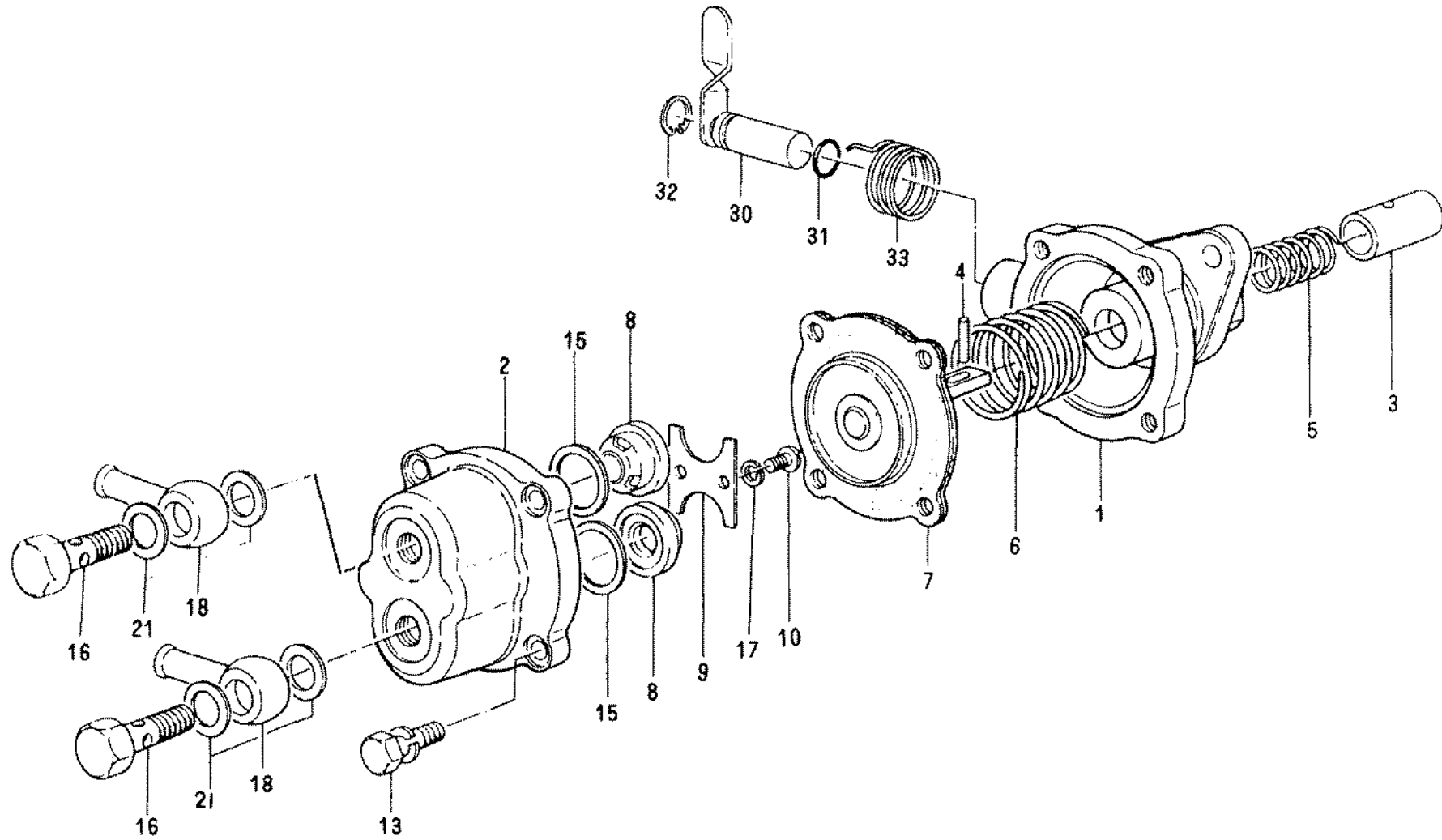

Key No.	Part No.	Part Name	Per Unit	FEED PUMP; INJ. PUMP (DIESEL KIKI)												L	S · C	I T C	Remarks	NOTE
				00000:00001:11111:11112:22222:22223:	:	:	:	:	:	:	:	:	:	:	:					
	515750-0300	PUMP ASM.; FEED	1	0	:	:	:	:	:	:	:	:	:	:	:	:	:			
	515750-0060	PUMP ASM.; FEED	1	0	:	:	:	:	:	:	:	:	:	:	:	:	:			
	515750-0330	PUMP ASM.; FEED	1	0	:	:	:	:	:	:	:	:	:	:	:	:	:			
1	515751-0030	HOUSING; FEED PUMP	1	000	:	:	:	:	:	:	:	:	:	:	:	:	1	A		
2	515729-1140	COVER	1	000	:	:	:	:	:	:	:	:	:	:	:	:	1	A		
3	515754-0030	TAPPET	1	000	:	:	:	:	:	:	:	:	:	:	:	:	1	A		
4	515759-0180	PIN	1	000	:	:	:	:	:	:	:	:	:	:	:	:	1	A		
5	515753-0010	SPRING	1	000	:	:	:	:	:	:	:	:	:	:	:	:	1	A		
6	515763-0010	SPRING	1	000	:	:	:	:	:	:	:	:	:	:	:	:	1	A		
7	515761-0020	DIAPHRAGM	1	000	:	:	:	:	:	:	:	:	:	:	:	:	1	A		
8	515755-0040	VALVE; CHECK	2	000	:	:	:	:	:	:	:	:	:	:	:	:	1	A		
9	515759-0190	RETAINER	1	000	:	:	:	:	:	:	:	:	:	:	:	:	1	A		
10	515759-0200	BOLT	2	000	:	:	:	:	:	:	:	:	:	:	:	:	1	A		
13	515759-0210	BOLT	4	000	:	:	:	:	:	:	:	:	:	:	:	:	1	A		
15	515729-1150	GASKET	2	000	:	:	:	:	:	:	:	:	:	:	:	:	1	A		
16	515729-1640	BOLT; EYE	2	000	:	:	:	:	:	:	:	:	:	:	:	:	1	A		
17	981391-3020	WASHER	1	00	:	:	:	:	:	:	:	:	:	:	:	:	1	A		
18	515759-0160	EYE	2	0	:	:	:	:	:	:	:	:	:	:	:	:	1	A		
18	515759-0160	EYE	1	00	:	:	:	:	:	:	:	:	:	:	:	:	1	A		
21	515759-0220	GASKET	4	000	:	:	:	:	:	:	:	:	:	:	:	:	1	A		
30	515759-0170	LEVER	1	000	:	:	:	:	:	:	:	:	:	:	:	:	1	A		
31	981325-5120	O-RING	1	000	:	:	:	:	:	:	:	:	:	:	:	:	1	A		
32	515729-1650	RING; SNAP	1	000	:	:	:	:	:	:	:	:	:	:	:	:	1	A		
33	515753-0020	SPRING	1	000	:	:	:	:	:	:	:	:	:	:	:	:	1	A		

FEED PUMP; INJECTION PUMP (DIESEL KIKI)

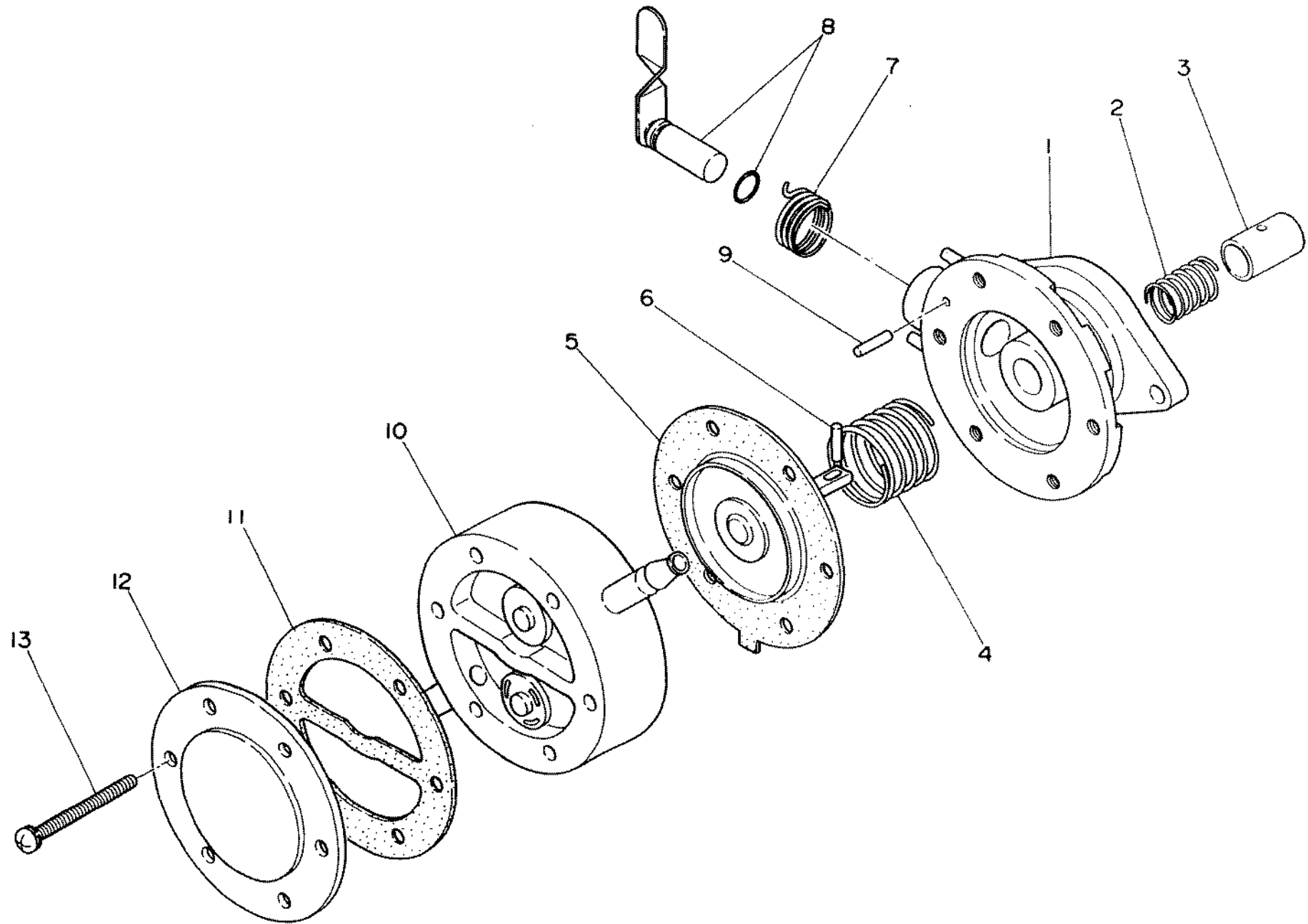

Key No.	Part No.	Part Name	Per Unit	FEED PUMP; INJ. PUMP (DIESEL KIKI)										L	S · C	I T C	Remarks	NOTE	
				00000:00001:11111:11112:22222:22223:	:	:	:	:	:	:	:	:	:						:
	515750-0290	PUMP ASM.; FEED	1	0	:	:	:	:	:	:	:	:	:	:	:	:	B		
1	515751-0090	COVER; BOTTOME	1	0	:	:	:	:	:	:	:	:	:	:	:	:	A		
2	515754-0040	SPRING; PISTON	1	0	:	:	:	:	:	:	:	:	:	:	:	:	A		
3	515754-0050	PISTON	1	0	:	:	:	:	:	:	:	:	:	:	:	:	A		
4	515753-0030	SPRING	1	0	:	:	:	:	:	:	:	:	:	:	:	:	A		
5	515759-0320	DIAPHRAGM	1	0	:	:	:	:	:	:	:	:	:	:	:	:	A		
6	515759-0330	PIN	1	0	:	:	:	:	:	:	:	:	:	:	:	:	A		
7	515753-0040	SPRING	1	0	:	:	:	:	:	:	:	:	:	:	:	:	A		
8	515759-0340	LEVER ASM.	1	0	:	:	:	:	:	:	:	:	:	:	:	:	A		
9	515759-0350	PIN	1	0	:	:	:	:	:	:	:	:	:	:	:	:	A		
10	515751-0100	BODY ASM.; TOP	1	0	:	:	:	:	:	:	:	:	:	:	:	:	A		
11	515759-0360	PACKING	1	0	:	:	:	:	:	:	:	:	:	:	:	:	A		
12	515759-0370	CAP	1	0	:	:	:	:	:	:	:	:	:	:	:	:	A		
13	515759-0380	SCREW	6	0	:	:	:	:	:	:	:	:	:	:	:	:	A		

NOZZLE HOLDER (DIESEL KIKI)

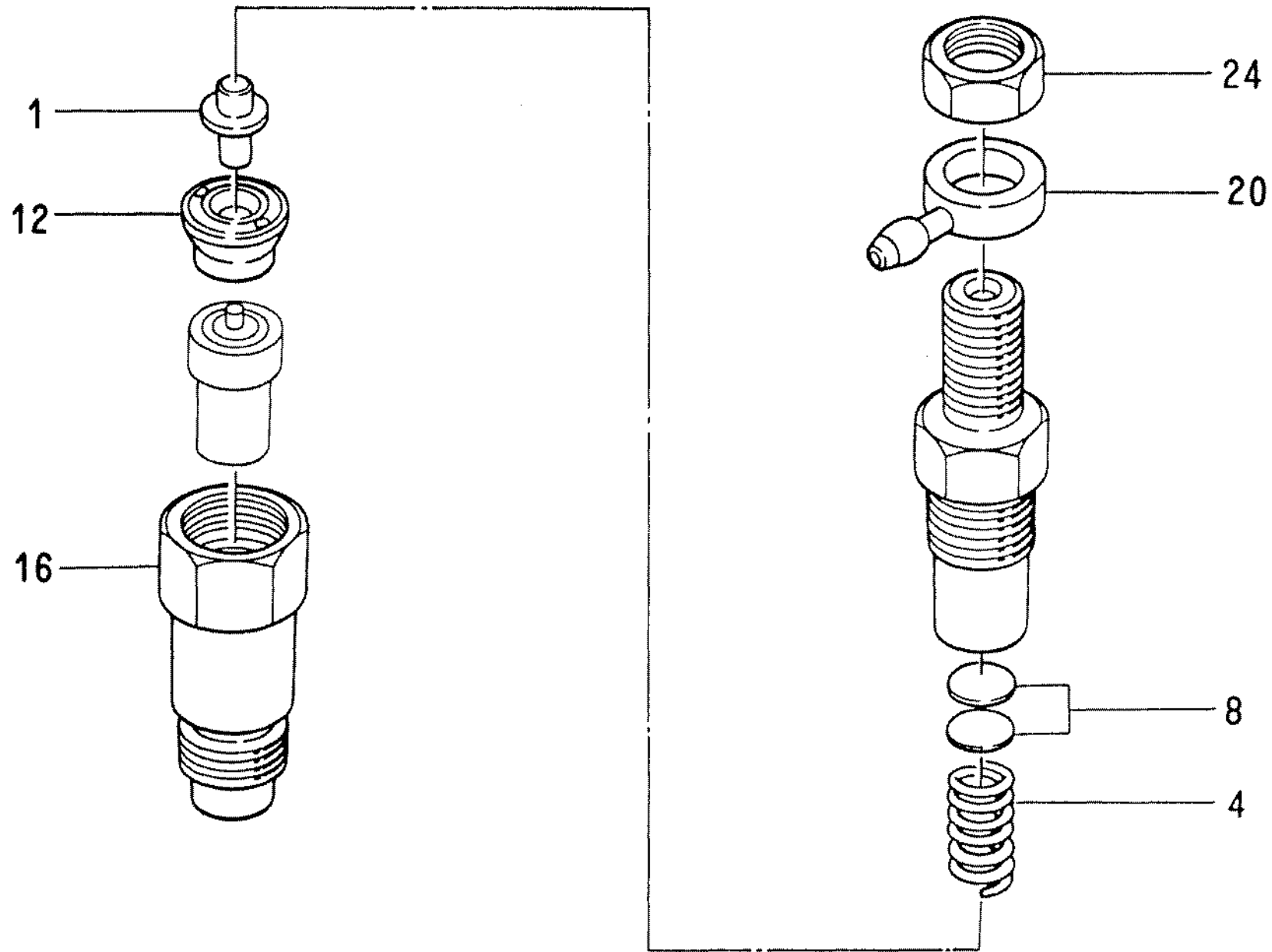

Key No.	Part No.	Part Name	Per Unit	NOZZLE HOLDER(DIESEL KIKI)												L	S C	I T C	Remarks	NOTE	
				00000:00001:11111:11112:22222:22223:	:	:	:	:	:	:	:	:	:	:	:						:
	515330-0160 515330-0161	HOLDER ASM.;NOZZLE HOLDER ASM.;NOZZLE	3 3	0	:	:	:	:	:	:	:	:	:	:	:	:	:	:			
1	915341-0020	ROD; PUSH	3	0	:	:	:	:	:	:	:	:	:	:	:	:	:	1	A		
4	515343-0040	SPRING;NOZZLE	3	0	:	:	:	:	:	:	:	:	:	:	:	:	:	1	A		
8	515339-0070	SHIM; T=0.50	A/R	0	:	:	:	:	:	:	:	:	:	:	:	:	:	1	A		
8	515339-0180	SHIM; T=0.52	A/R	0	:	:	:	:	:	:	:	:	:	:	:	:	:	1	A		
8	515339-0190	SHIM; T=0.54	A/R	0	:	:	:	:	:	:	:	:	:	:	:	:	:	1	A		
8	515339-0200	SHIM; T=0.56	A/R	0	:	:	:	:	:	:	:	:	:	:	:	:	:	1	A		
8	515339-0210	SHIM; T=0.58	A/R	0	:	:	:	:	:	:	:	:	:	:	:	:	:	1	A		
8	515339-0080	SHIM; T=0.60	A/R	0	:	:	:	:	:	:	:	:	:	:	:	:	:	1	A		
8	515339-0220	SHIM; T=0.62	A/R	0	:	:	:	:	:	:	:	:	:	:	:	:	:	1	A		
8	515339-0230	SHIM; T=0.64	A/R	0	:	:	:	:	:	:	:	:	:	:	:	:	:	1	A		
8	515339-0240	SHIM; T=0.66	A/R	0	:	:	:	:	:	:	:	:	:	:	:	:	:	1	A		
8	515339-0250	SHIM; T=0.68	A/R	0	:	:	:	:	:	:	:	:	:	:	:	:	:	1	A		
8	515339-0090	SHIM; T=0.70	A/R	0	:	:	:	:	:	:	:	:	:	:	:	:	:	1	A		
8	515339-0260	SHIM; T=0.72	A/R	0	:	:	:	:	:	:	:	:	:	:	:	:	:	1	A		
8	515339-0270	SHIM; T=0.74	A/R	0	:	:	:	:	:	:	:	:	:	:	:	:	:	1	A		
8	515339-0280	SHIM; T=0.76	A/R	0	:	:	:	:	:	:	:	:	:	:	:	:	:	1	A		
8	515339-0290	SHIM; T=0.78	A/R	0	:	:	:	:	:	:	:	:	:	:	:	:	:	1	A		
8	515339-0100	SHIM; T=0.80	A/R	0	:	:	:	:	:	:	:	:	:	:	:	:	:	1	A		
8	515339-0300	SHIM; T=0.82	A/R	0	:	:	:	:	:	:	:	:	:	:	:	:	:	1	A		
8	515339-0310	SHIM; T=0.84	A/R	0	:	:	:	:	:	:	:	:	:	:	:	:	:	1	A		
8	515339-0320	SHIM; T=0.86	A/R	0	:	:	:	:	:	:	:	:	:	:	:	:	:	1	A		
8	515339-0330	SHIM; T=0.88	A/R	0	:	:	:	:	:	:	:	:	:	:	:	:	:	1	A		
8	515339-0110	SHIM; T=0.90	A/R	0	:	:	:	:	:	:	:	:	:	:	:	:	:	1	A		
8	515339-0340	SHIM; T=0.92	A/R	0	:	:	:	:	:	:	:	:	:	:	:	:	:	1	A		
8	515339-0350	SHIM; T=0.94	A/R	0	:	:	:	:	:	:	:	:	:	:	:	:	:	1	A		
8	515339-0360	SHIM; T=0.96	A/R	0	:	:	:	:	:	:	:	:	:	:	:	:	:	1	A		
8	515339-0370	SHIM; T=0.98	A/R	0	:	:	:	:	:	:	:	:	:	:	:	:	:	1	A		
8	515339-0120	SHIM; T=1.00	A/R	0	:	:	:	:	:	:	:	:	:	:	:	:	:	1	A		
8	515339-0380	SHIM; T=1.02	A/R	0	:	:	:	:	:	:	:	:	:	:	:	:	:	1	A		
8	515339-0390	SHIM; T=1.04	A/R	0	:	:	:	:	:	:	:	:	:	:	:	:	:	1	A		
8	515339-0400	SHIM; T=1.06	A/R	0	:	:	:	:	:	:	:	:	:	:	:	:	:	1	A		
8	515339-0410	SHIM; T=1.08	A/R	0	:	:	:	:	:	:	:	:	:	:	:	:	:	1	A		
8	515339-0130	SHIM; T=1.10	A/R	0	:	:	:	:	:	:	:	:	:	:	:	:	:	1	A		
8	515339-0420	SHIM; T=1.12	A/R	0	:	:	:	:	:	:	:	:	:	:	:	:	:	1	A		
8	515339-0430	SHIM; T=1.14	A/R	0	:	:	:	:	:	:	:	:	:	:	:	:	:	1	A		
8	515339-0440	SHIM; T=1.16	A/R	0	:	:	:	:	:	:	:	:	:	:	:	:	:	1	A		
8	515339-0450	SHIM; T=1.18	A/R	0	:	:	:	:	:	:	:	:	:	:	:	:	:	1	A		
8	515339-0140	SHIM; T=1.20	A/R	0	:	:	:	:	:	:	:	:	:	:	:	:	:	1	A		
8	515339-0460	SHIM; T=1.22	A/R	0	:	:	:	:	:	:	:	:	:	:	:	:	:	1	A		
8	515339-0470	SHIM; T=1.24	A/R	0	:	:	:	:	:	:	:	:	:	:	:	:	:	1	A		
8	515339-0480	SHIM; T=1.26	A/R	0	:	:	:	:	:	:	:	:	:	:	:	:	:	1	A		
8	515339-0490	SHIM; T=1.28	A/R	0	:	:	:	:	:	:	:	:	:	:	:	:	:	1	A		
8	515339-0150	SHIM; T=1.30	A/R	0	:	:	:	:	:	:	:	:	:	:	:	:	:	1	A		
8	515339-0500	SHIM; T=1.32	A/R	0	:	:	:	:	:	:	:	:	:	:	:	:	:	1	A		
8	515339-0510	SHIM; T=1.34	A/R	0	:	:	:	:	:	:	:	:	:	:	:	:	:	1	A		
8	515339-0520	SHIM; T=1.36	A/R	0	:	:	:	:	:	:	:	:	:	:	:	:	:	1	A		
8	515339-0530	SHIM; T=1.38	A/R	0	:	:	:	:	:	:	:	:	:	:	:	:	:	1	A		

Key No.	Part No.	Part Name	Per Unit	NOZZLE HOLDER(DIESEL KIKI)												L	S · C	I T C	Remarks	NOTE
				00000:00001:11111:11112:22222:22223:	:	:	:	:	:	:	:	:	:	:	:					
8	515339-0160	SHIM; T=1.40	A/R	0	:	:	:	:	:	:	:	:	:	:	1	A				
8	515339-0540	SHIM; T=1.42	A/R	0	:	:	:	:	:	:	:	:	:	:	1	A				
8	515339-0550	SHIM; T=1.44	A/R	0	:	:	:	:	:	:	:	:	:	:	1	A				
8	515339-0560	SHIM; T=1.46	A/R	0	:	:	:	:	:	:	:	:	:	:	1	A				
8	515339-0570	SHIM; T=1.48	A/R	0	:	:	:	:	:	:	:	:	:	:	1	A				
8	515339-0170	SHIM; T=1.50	A/R	0	:	:	:	:	:	:	:	:	:	:	1	A				
8	515339-0580	SHIM; T=1.52	A/R	0	:	:	:	:	:	:	:	:	:	:	1	A				
8	515339-0590	SHIM; T=1.54	A/R	0	:	:	:	:	:	:	:	:	:	:	1	A				
12	915331-0040	SPACER		2	0	:	:	:	:	:	:	:	:	:	1	A				
16	515332-0040	NUT;RETAINING		2	0	:	:	:	:	:	:	:	:	:	1	A				
20	515355-0010	EYE		2	0	:	:	:	:	:	:	:	:	:	1	A				
24	915332-0100	NUT		2	0	:	:	:	:	:	:	:	:	:	1	A				

MEMO

STARTER (NIKKO)

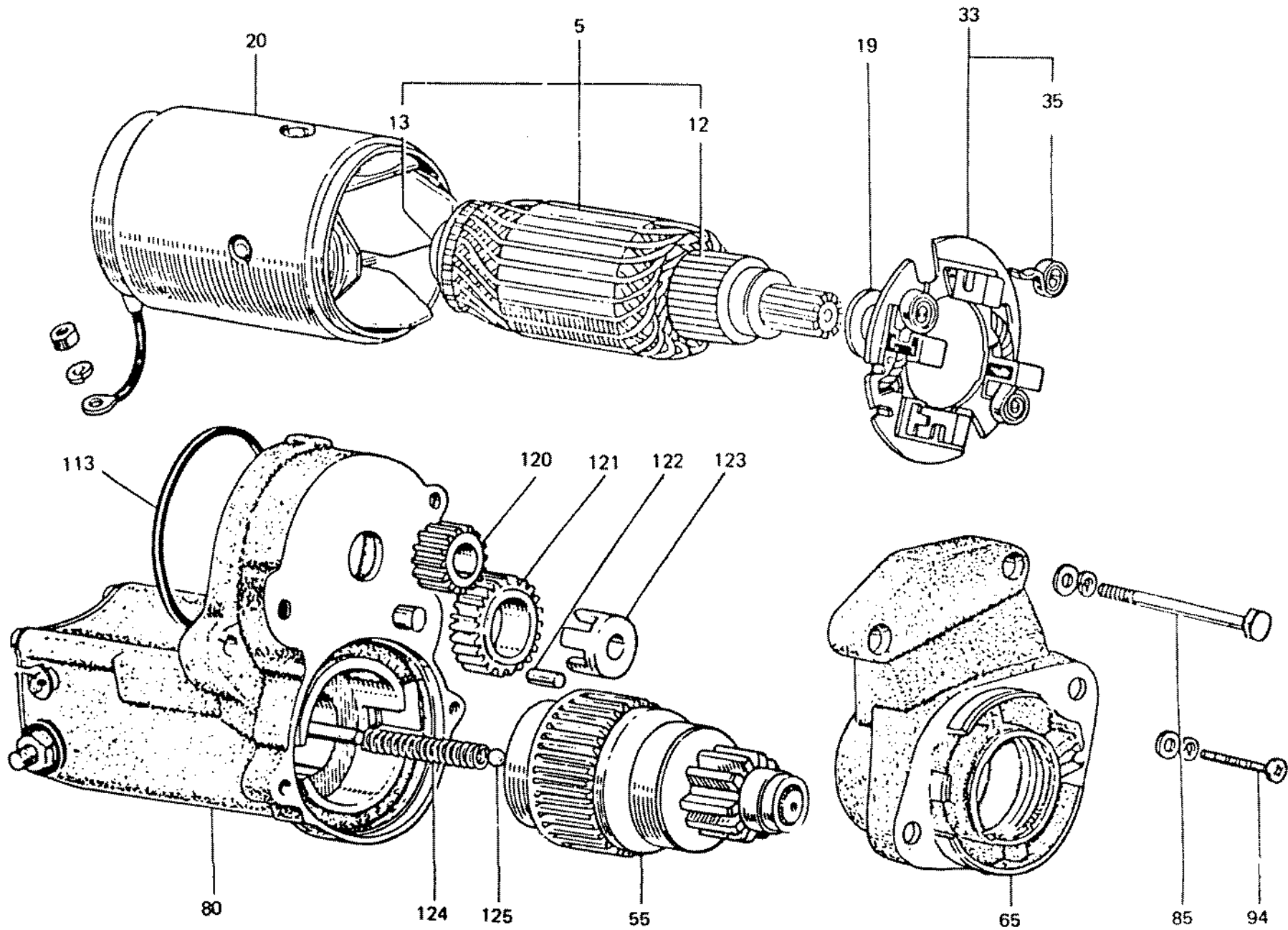

STARTER (NIKKO)

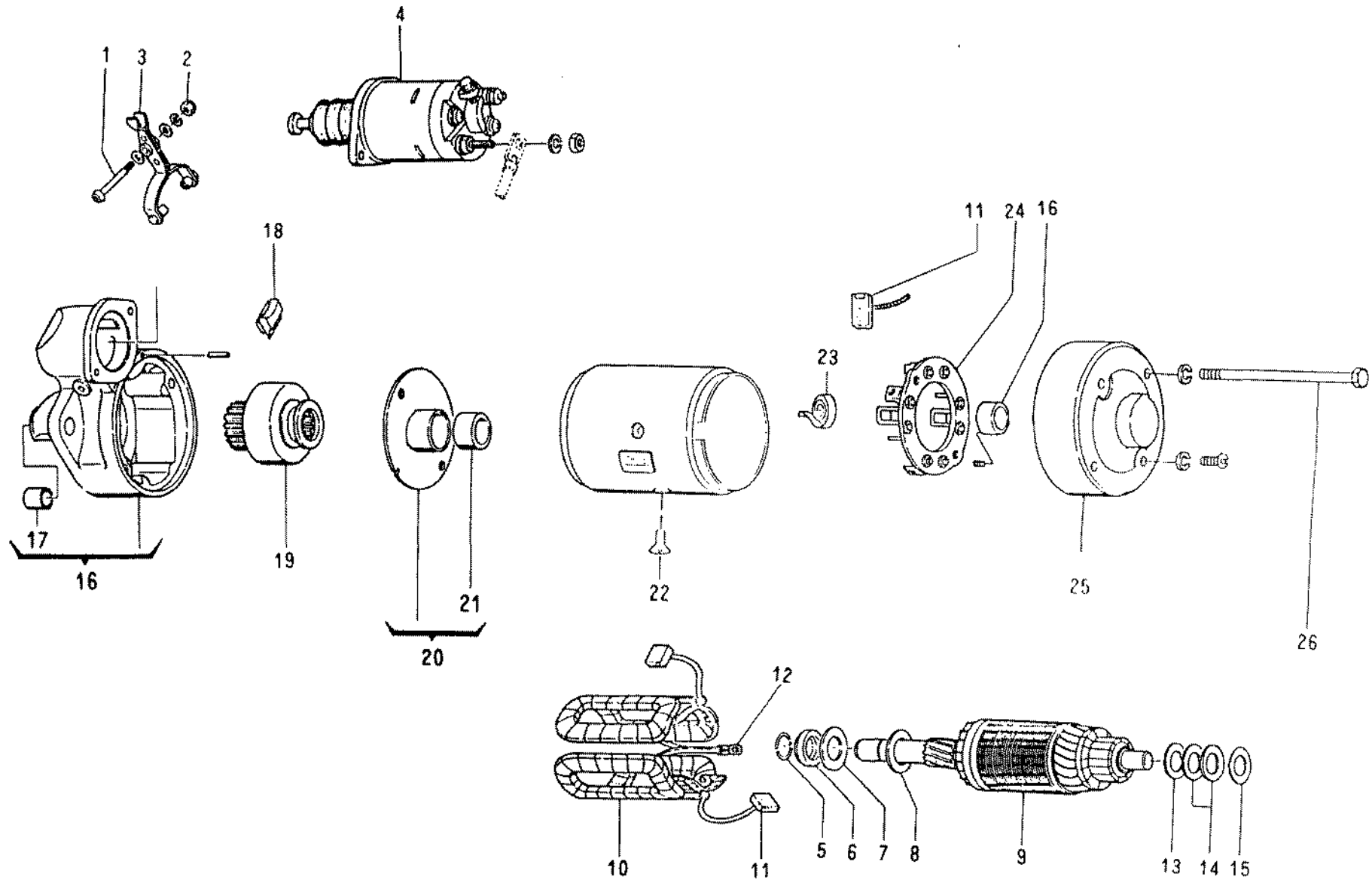

Key No.	Part No.	Part Name	Per Unit	STARTER(NIKKO)										L	S • C	I T C	Remarks	NOTE	
				00000:00001:11111:11112:22222:22223:	:	:	:	:	:	:	:	:	:						:
	581100-1232	STARTER ASM.;12V-1KW	1	0	:	:	:	:	:	:	:	:	:	:	:	:	B		
1	181129-0400	PIN;LEVER	1	0	:	:	:	:	:	:	:	:	:	:	:	:	1	A	
2	509400-0250	NUT	1	0	:	:	:	:	:	:	:	:	:	:	:	:	1	A	
3	581127-0190	LEVER ASM.;SHIFT	1	0	:	:	:	:	:	:	:	:	:	:	:	:	1	A	
4	581151-0410	SWICH ASM.;MAGNETIC	1	0	:	:	:	:	:	:	:	:	:	:	:	:	1	A	
5	982125-1930	CLIP RING	2	0	:	:	:	:	:	:	:	:	:	:	:	:	1	A	
6	581129-0550	STOPPER;PINION	1	0	:	:	:	:	:	:	:	:	:	:	:	:	1	A	
7	581128-0270	WASHER;INSULATOR	1	0	:	:	:	:	:	:	:	:	:	:	:	:	1	A	
8	982115-3470	WASHER	1	0	:	:	:	:	:	:	:	:	:	:	:	:	1	A	
9	581121-0300	ARMATURE ASM.	1	0	:	:	:	:	:	:	:	:	:	:	:	:	1	A	
10	581112-0210	COIL ASM.;FIELD	1	0	:	:	:	:	:	:	:	:	:	:	:	:	1	A	
11	581116-0330	BRUSH ASM.	4	0	:	:	:	:	:	:	:	:	:	:	:	:	1	A	
12	581129-1170	BUSH;GUM	1	0	:	:	:	:	:	:	:	:	:	:	:	:	1	A	
13	581128-0340	WASHER	1	0	:	:	:	:	:	:	:	:	:	:	:	:	1	A	
14	581128-0280	WASHER	2	0	:	:	:	:	:	:	:	:	:	:	:	:	1	A	
15	509503-0460	WASHER;INSULATOR	1	0	:	:	:	:	:	:	:	:	:	:	:	:	1	A	
16	581113-0370	BRACKET ASM.;FRT.	2	0	:	:	:	:	:	:	:	:	:	:	:	:	1	A	
17	581129-0090	METAL FRT.AND RR.	1	0	:	:	:	:	:	:	:	:	:	:	:	:	2	A	
18	581129-1780	PACKING	1	0	:	:	:	:	:	:	:	:	:	:	:	:	1	A	
19	581122-0180	CLUTCH ASM.;PINION	1	0	:	:	:	:	:	:	:	:	:	:	:	:	1	A	
20	581114-0200	BRACKET ASM.;CENTER	1	0	:	:	:	:	:	:	:	:	:	:	:	:	1	A	
21	581129-1790	METAL;CENTER	1	0	:	:	:	:	:	:	:	:	:	:	:	:	2	A	
22	181129-0430	SCREW;DISH	4	0	:	:	:	:	:	:	:	:	:	:	:	:	1	A	
23	581117-0160	SPRING;BRUSH	4	0	:	:	:	:	:	:	:	:	:	:	:	:	1	A	
24	581116-0340	HOLDER ASM.;BRUSH	1	0	:	:	:	:	:	:	:	:	:	:	:	:	1	A	
25	581115-0330	BRACKET ASM.;RR.	1	0	:	:	:	:	:	:	:	:	:	:	:	:	1	A	
26	581129-1800	BOLT	2	0	:	:	:	:	:	:	:	:	:	:	:	:	1	A	

STARTER (DENSO)

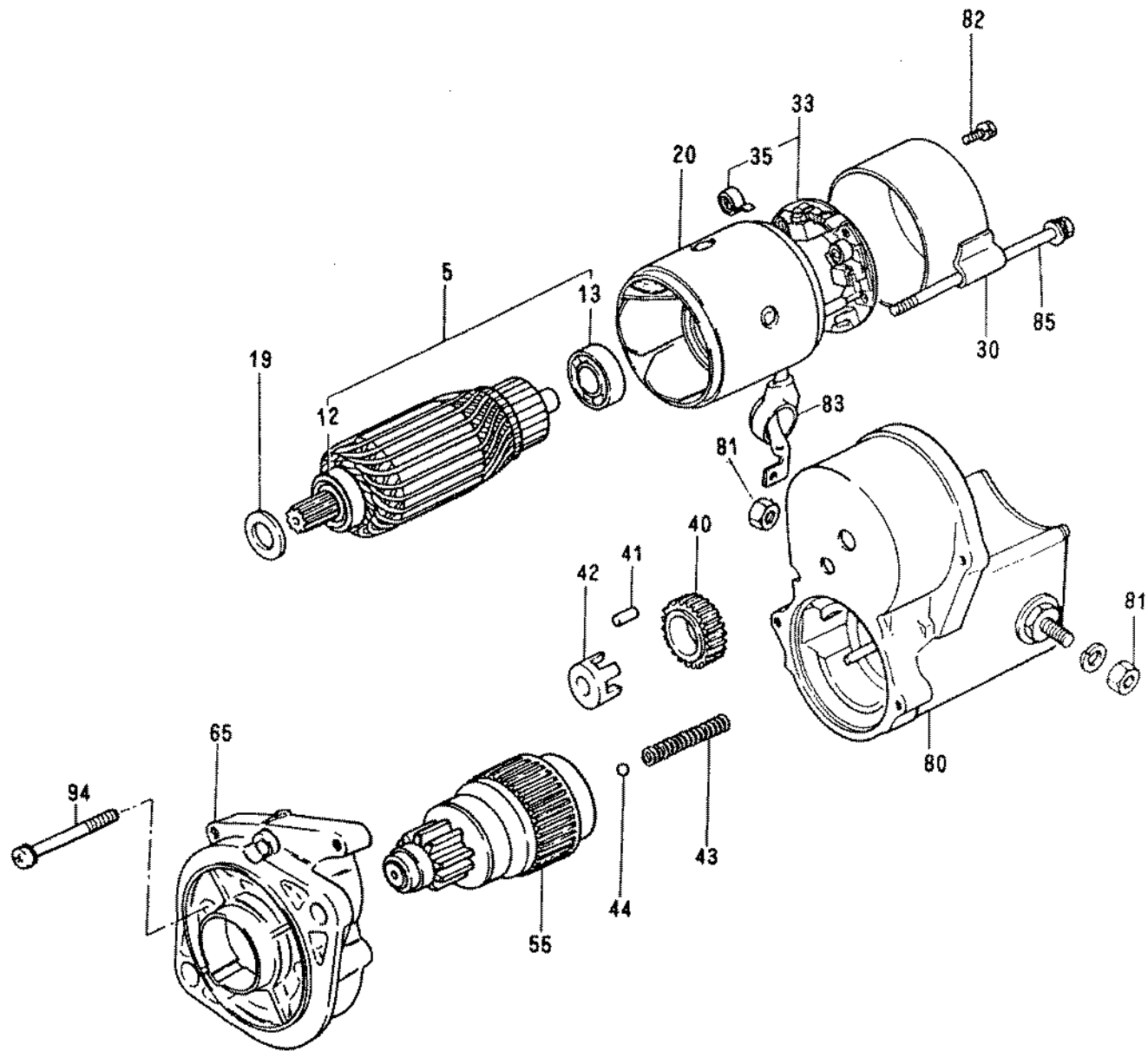

Key No.	Part No.	Part Name	Per Unit	STARTER(DENSO)										L	S · C	I T C	Remarks	N O T E	
				00000:00001:11111:11112:22222:22223:	:	:	:	:	:	:	:	:	:						:
	581100-1650	STARTER ASM.;12V-1KW	1	0	:	:	:	:	:	:	:	:	:	:	:	:	B		
5	581121-0310	ARMATURE ASM.	1	0	:	:	:	:	:	:	:	:	:	:	:	:	1	A	
12	509800-0790	BEARING;BALL.FRT.	1	0	:	:	:	:	:	:	:	:	:	:	:	:	2	A	
13	509800-0400	BEARING;BALL.RR.	1	0	:	:	:	:	:	:	:	:	:	:	:	:	2	A	
19	581129-1840	WASHER;FELT	1	0	:	:	:	:	:	:	:	:	:	:	:	:	1	A	
20	581111-0110	YOKE ASM.	1	0	:	:	:	:	:	:	:	:	:	:	:	:	1	A	
30	581115-0340	COVER ASM.;RR.	1	0	:	:	:	:	:	:	:	:	:	:	:	:	1	A	
33	581118-0220	HOLDER ASM.;BRUSH	1	0	:	:	:	:	:	:	:	:	:	:	:	:	1	A	
35	581117-0070	SPRING;BRUSH	4	0	:	:	:	:	:	:	:	:	:	:	:	:	2	A	
40	581123-0110	GEAR;IDLE	1	0	:	:	:	:	:	:	:	:	:	:	:	:	1	A	
41	581129-0990	ROLLER	5	0	:	:	:	:	:	:	:	:	:	:	:	:	1	A	
42	581129-1000	RETAINER	1	0	:	:	:	:	:	:	:	:	:	:	:	:	1	A	
43	581129-0960	SPRING;COIL	1	0	:	:	:	:	:	:	:	:	:	:	:	:	1	A	
44	581129-0920	BALL;STEEL	1	0	:	:	:	:	:	:	:	:	:	:	:	:	1	A	
55	581124-0060	CLUTCH;PINION	1	0	:	:	:	:	:	:	:	:	:	:	:	:	1	A	
65	581129-1850	CASE ASM.;GEAR	1	0	:	:	:	:	:	:	:	:	:	:	:	:	1	A	
80	581151-0420	SWITCH ASM.;MAGNETIC	1	0	:	:	:	:	:	:	:	:	:	:	:	:	1	A	
81	509400-0420	NUT	2	0	:	:	:	:	:	:	:	:	:	:	:	:	1	A	
82	581129-1810	SCREW;SEMS	2	0	:	:	:	:	:	:	:	:	:	:	:	:	1	A	
83	581119-0290	CAP;RUBBER	1	0	:	:	:	:	:	:	:	:	:	:	:	:	1	A	
85	581129-1830	BOLT;THROUGH	2	0	:	:	:	:	:	:	:	:	:	:	:	:	1	A	
94	581129-1820	BOLT;GEAR CASE FIX.	2	0	:	:	:	:	:	:	:	:	:	:	:	:	1	A	

STARTER (NIKKO)

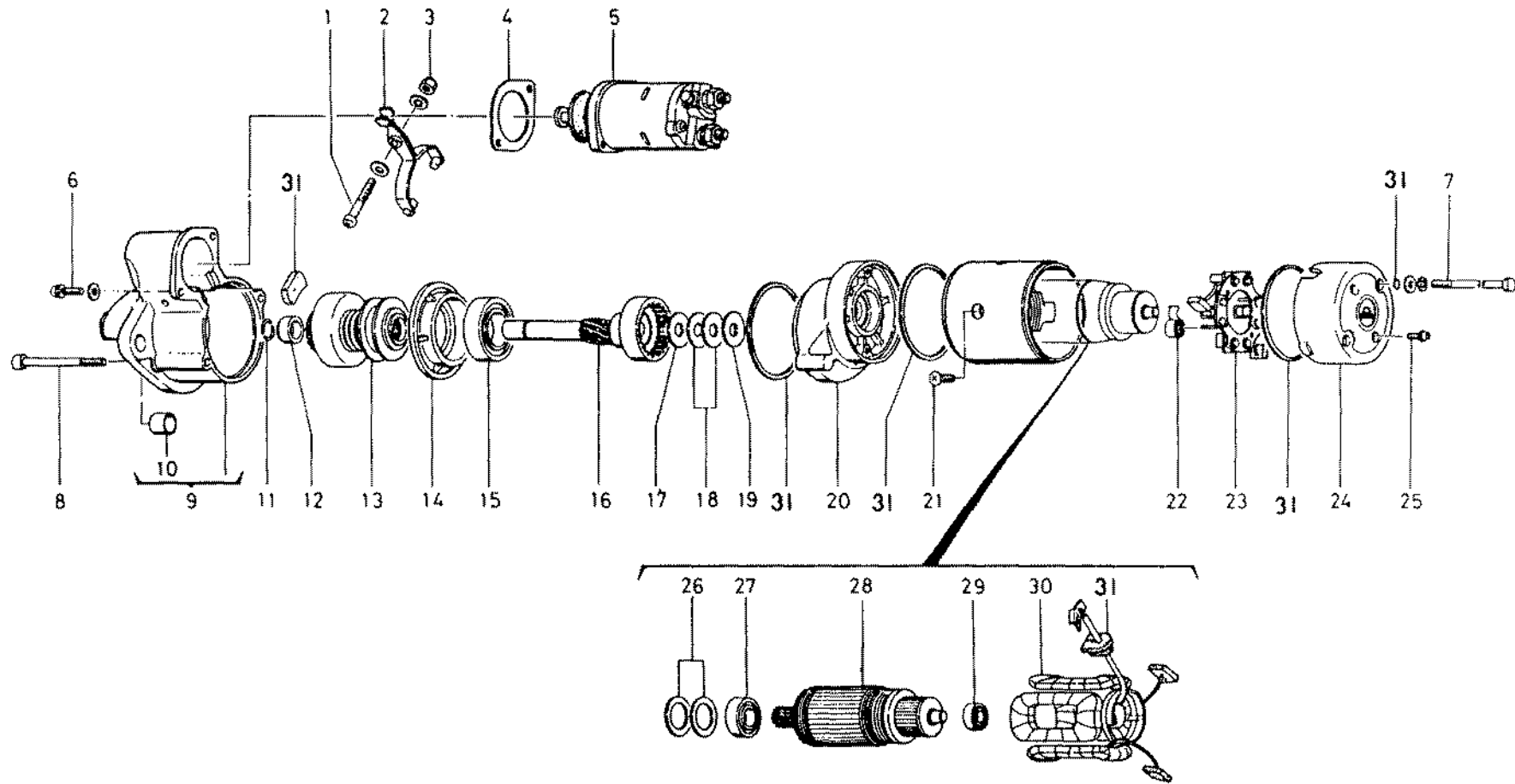

62 E 62E-1

STARTER (HITACHI)

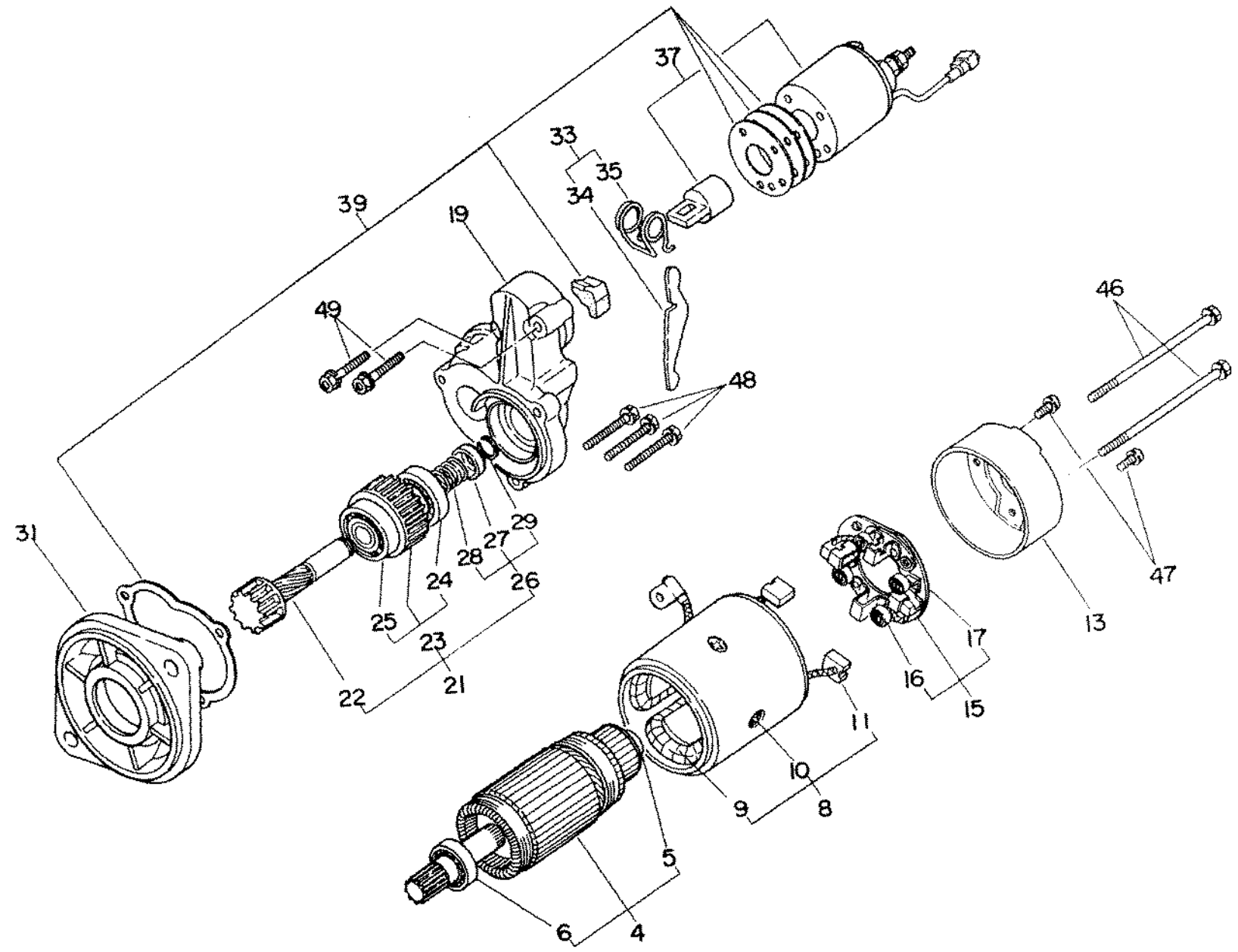

Key No.	Part No.	Part Name	Per Unit	STARTER(HITACHI)										L	S · C	I T C	Remarks	NOTE	
				00000:00001:11111:11112:22222:22223:	:	:	:	:	:	:	:	:	:						:
	581100-2100	STARTER ASM. :	1	0	:	:	:	:	:	:	:	:	:	:	:	:			
4	894242-0590	ARMATURE ASM.	1	0	:	:	:	:	:	:	:	:	:	:	:	:			
5	894228-4360	BEARING;BALL (1)	1	0	:	:	:	:	:	:	:	:	:	:	:	:			
6	894228-4370	BEARING;BALL (2)	1	0	:	:	:	:	:	:	:	:	:	:	:	:			
8	N.P.N.	YOKE ASM	1	0	:	:	:	:	:	:	:	:	:	:	:	:			
9	894242-0600	COIL ASM.;FIELD	1	0	:	:	:	:	:	:	:	:	:	:	:	:			
10	894228-4390	SDREW;POLE CORE	4	0	:	:	:	:	:	:	:	:	:	:	:	:			
11	894242-0610	BRUSH (+)	2	0	:	:	:	:	:	:	:	:	:	:	:	:			
13	581115-0620	COVER ASM.;REAR	1	0	:	:	:	:	:	:	:	:	:	:	:	:			
15	894242-0630	HOLDER ASM.;BRUSH	1	0	:	:	:	:	:	:	:	:	:	:	:	:			
16	894242-0640	SPRING;BRUSH	4	0	:	:	:	:	:	:	:	:	:	:	:	:			
17	894242-0650	BRUSH (-)	2	0	:	:	:	:	:	:	:	:	:	:	:	:			
19	894242-0620	HOUSING;CENTER	1	0	:	:	:	:	:	:	:	:	:	:	:	:			
21	581123-0340	CLUTCH ASM.;PINION	1	0	:	:	:	:	:	:	:	:	:	:	:	:			
22	581129-0640	SHAFT;PINION	1	0	:	:	:	:	:	:	:	:	:	:	:	:			
23	581123-0350	CLUTCH ASM.	1	0	:	:	:	:	:	:	:	:	:	:	:	:			
24	894228-4480	BEARING;BALL (3)	1	0	:	:	:	:	:	:	:	:	:	:	:	:			
25	894228-4490	BEARING;BALL (3)	1	0	:	:	:	:	:	:	:	:	:	:	:	:			
26	894228-4500	STOPPER SET	1	0	:	:	:	:	:	:	:	:	:	:	:	:			
27	N.P.N.	STOPPER	1	0	:	:	:	:	:	:	:	:	:	:	:	:			
28	N.P.N.	SPRING;RETURN	1	0	:	:	:	:	:	:	:	:	:	:	:	:			
29	N.P.N.	CLIP	1	0	:	:	:	:	:	:	:	:	:	:	:	:			
31	581113-0530	GEAR CASE	1	0	:	:	:	:	:	:	:	:	:	:	:	:			
33	581127-0270	LEVER SET;SHIFT	1	0	:	:	:	:	:	:	:	:	:	:	:	:			
34	N.P.N.	LEVER;SHIFT	1	0	:	:	:	:	:	:	:	:	:	:	:	:			
35	N.P.N.	SPRING;TORSION	1	0	:	:	:	:	:	:	:	:	:	:	:	:			
37	581151-0670	SWITCH ASM.;MAGNETIC	1	0	:	:	:	:	:	:	:	:	:	:	:	:			
39	581118-0370	COVER KIT;DUST	1	0	:	:	:	:	:	:	:	:	:	:	:	:			
40	N.P.N.	COVER;DUST (R)	1	0	:	:	:	:	:	:	:	:	:	:	:	:			
41	N.P.N.	COVER;DUST (B)	1	0	:	:	:	:	:	:	:	:	:	:	:	:			
42	N.P.N.	COVER;DUST (C)	1	0	:	:	:	:	:	:	:	:	:	:	:	:			
43	N.P.N.	COVER;DUST (D)	1	0	:	:	:	:	:	:	:	:	:	:	:	:			
44	N.P.N.	COVER;DUST (F)	1	0	:	:	:	:	:	:	:	:	:	:	:	:			
46	894242-0710	BOLT;THROUGH	2	0	:	:	:	:	:	:	:	:	:	:	:	:			
47	N.P.N.	SCREW	2	0	:	:	:	:	:	:	:	:	:	:	:	:			
48	581129-2630	BOLT	3	0	:	:	:	:	:	:	:	:	:	:	:	:			
49	901045-6320	BOLT	2	0	:	:	:	:	:	:	:	:	:	:	:	:			

STARTER (HITACHI)

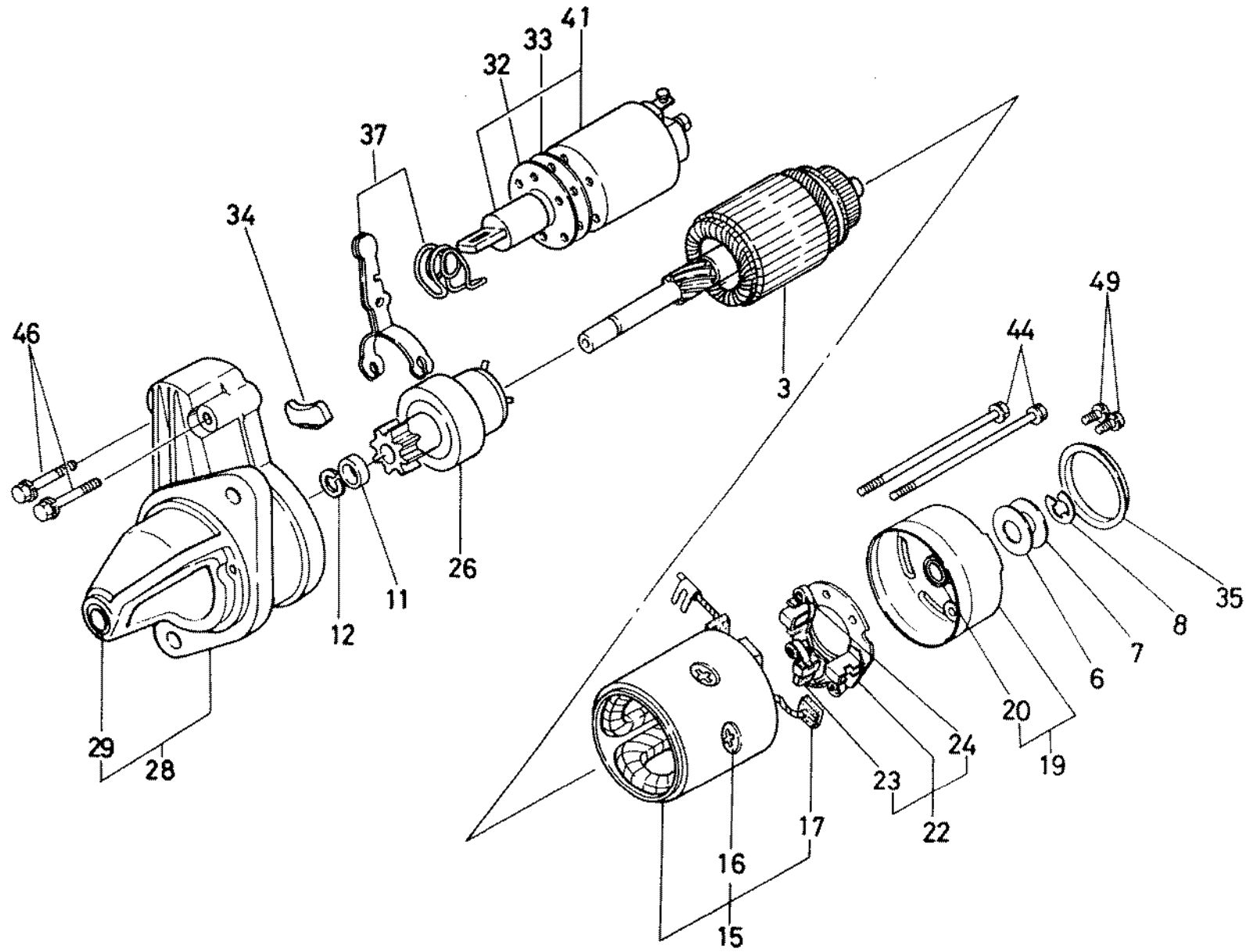

GENERATOR (HITACHI)

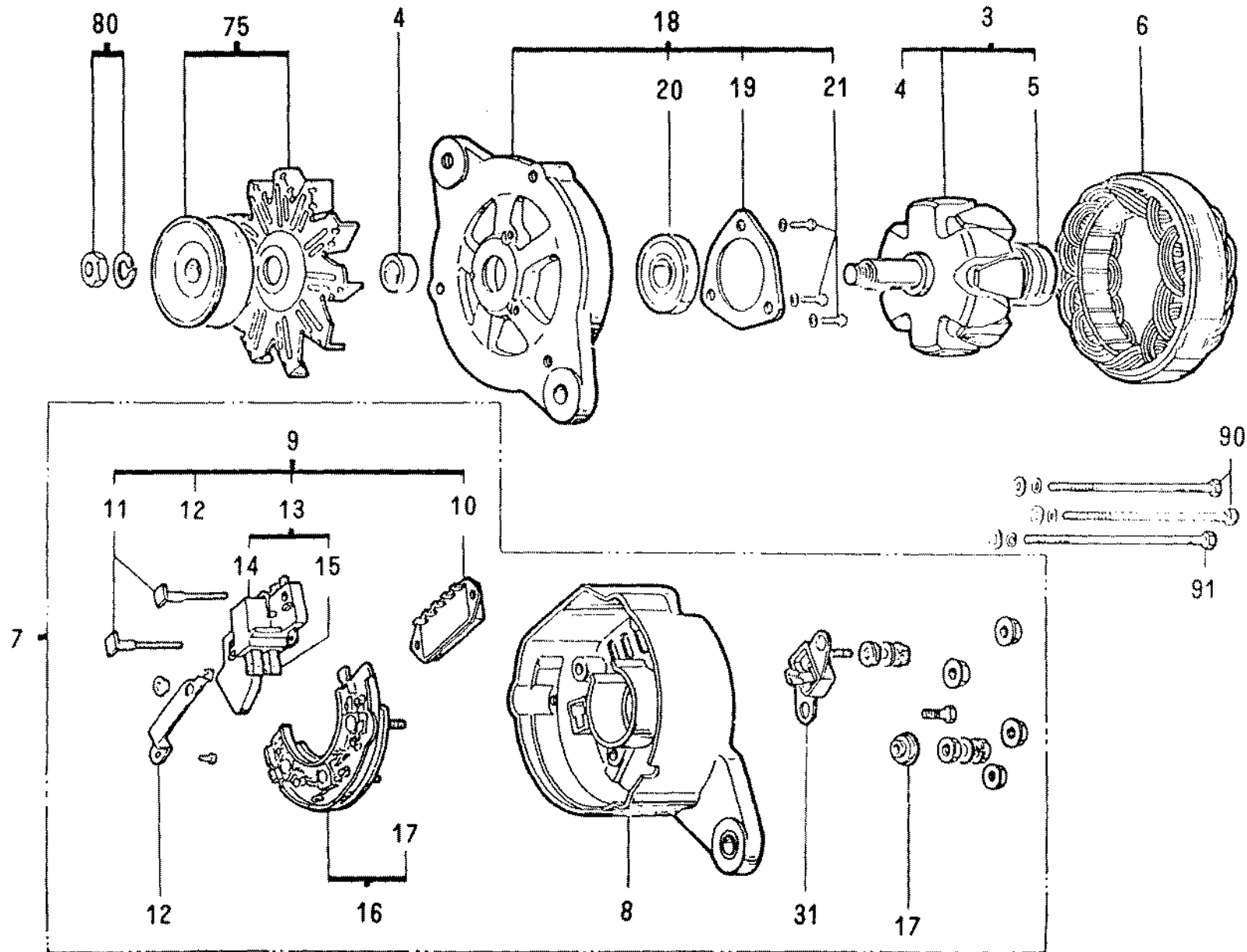

Key No.	Part No.	Part Name	Per Unit	GENERATOR (HITACHI)										L	S C	I T C	Remarks	NOTE	
				00000:00001:11111:11112:22222:22223:	:	:	:	:	:	:	:	:	:						:
	581200-3040	GENERATOR ASM.; 12V-20A	1	0	:	:	:	:	:	:	:	:	:	:	:	:			
	581200-3041	GENERATOR ASM.; 12V-20A	1	0	:	:	:	:	:	:	:	:	:	:	:	:			
	581200-3042	GENERATOR ASM.; 12V-20A	1	0	:	:	:	:	:	:	:	:	:	:	:	:			
3	581221-0540	ROTOR ASM.	1	0	:	:	:	:	:	:	:	:	:	:	:	:			
4	N.P.N	SPACER	1	0	:	:	:	:	:	:	:	:	:	:	:	:			
5	900090-1810	BEARING; BALL	1	0	:	:	:	:	:	:	:	:	:	:	:	:			
6	581211-0500	STATER ASM.	1	0	:	:	:	:	:	:	:	:	:	:	:	:			
7	581214-1040	COVER ASM.; RR.	1	0	:	:	:	:	:	:	:	:	:	:	:	:			
8	581214-1320	COVER; RR.	1	0	:	:	:	:	:	:	:	:	:	:	:	:			
9	581215-0380	REGULATOR ASM.; BRUSH	1	0	:	:	:	:	:	:	:	:	:	:	:	:			
10	581270-0040	REGULATOR ASM.; IC	1	0	:	:	:	:	:	:	:	:	:	:	:	:			
11	581229-1660	BOLT; M5	2	0	:	:	:	:	:	:	:	:	:	:	:	:			
12	N.P.N	PLATE; TERMINAL	1	0	:	:	:	:	:	:	:	:	:	:	:	:			
13	581215-0390	BRUSH ASM.	1	0	:	:	:	:	:	:	:	:	:	:	:	:			
14	N.P.N	HOLDER; BRUSH	1	0	:	:	:	:	:	:	:	:	:	:	:	:			
15	581215-0400	BRUSH	2	0	:	:	:	:	:	:	:	:	:	:	:	:			
16	581262-0050	DIODE ASM.	1	0	:	:	:	:	:	:	:	:	:	:	:	:			
17	N.P.N	BRUSH; INSULATOR	1	0	:	:	:	:	:	:	:	:	:	:	:	:			
18	581213-0430	COVER ASM.; TRI	1	0	:	:	:	:	:	:	:	:	:	:	:	:			
19	581229-0290	RETAINER; BRG.	1	0	:	:	:	:	:	:	:	:	:	:	:	:			
20	509800-0870	BEARING; BALL	1	0	:	:	:	:	:	:	:	:	:	:	:	:			
21	581229-1650	SCREW KIT	1	0	:	:	:	:	:	:	:	:	:	:	:	:			
31	581229-1620	BOLT ASM.; TERMINAL	1	0	:	:	:	:	:	:	:	:	:	:	:	:			
75	581222-0570	PULLEY ASM.	1	0	:	:	:	:	:	:	:	:	:	:	:	:			
80	982235-0150	NUT ASM.; PULLEY	1	0	:	:	:	:	:	:	:	:	:	:	:	:			
90	581229-1820	BOLT; THROUGH	2	0	:	:	:	:	:	:	:	:	:	:	:	:			
91	581229-1830	BOLT; THROUGH	1	0	:	:	:	:	:	:	:	:	:	:	:	:			

GENERATOR (NIKKO)

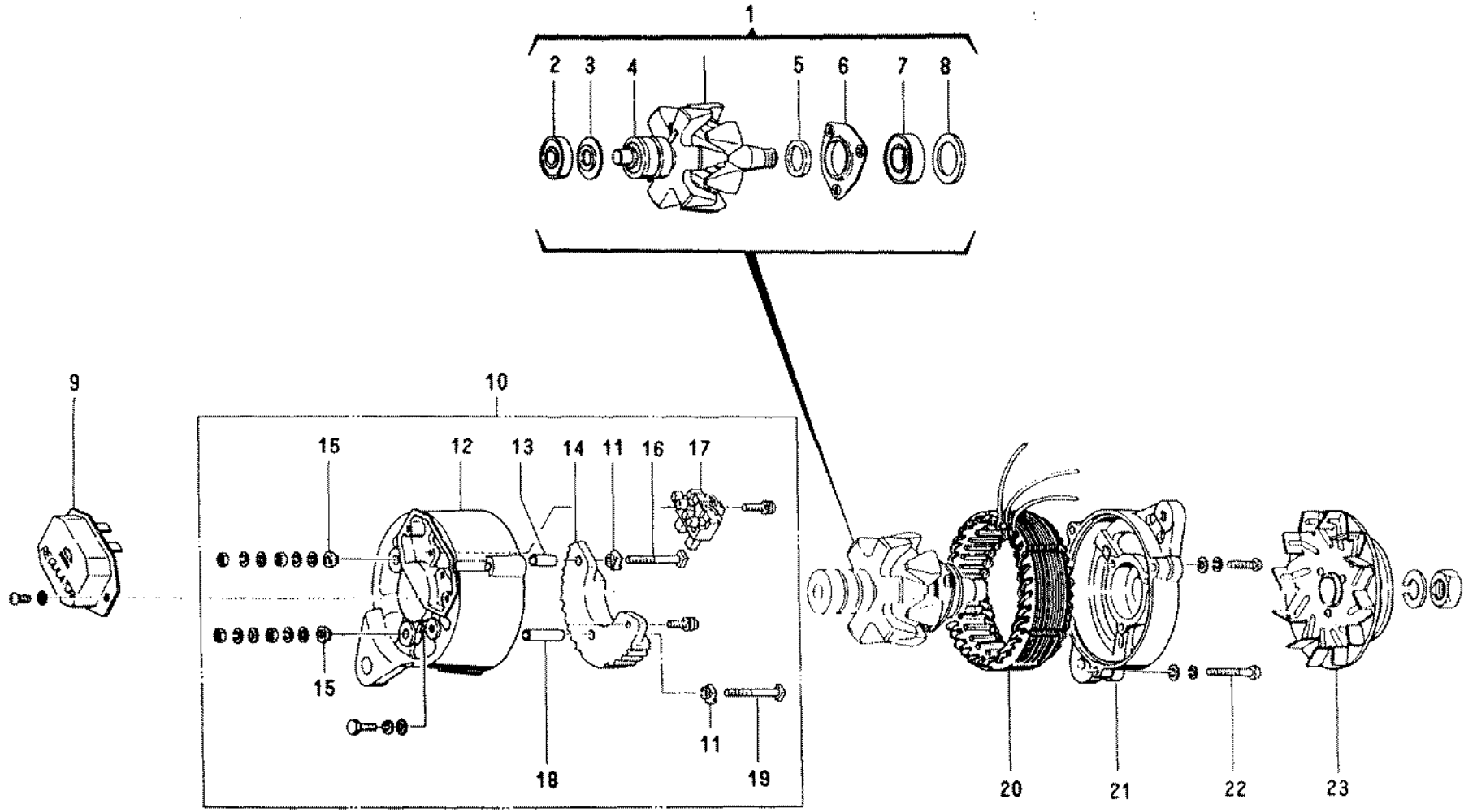

Key No.	Part No.	Part Name	Per Unit	GENERATOR(NIKKO)										L	S · C	I T C	Remarks	NOTE	
				00000:00001:11111:11112:22222:22223:	:	:	:	:	:	:	:	:	:						:
	581200-2210	GENERATOR ASM.;	1	0	:	:	:	:	:	:	:	:	:	:	:	:	B		
1	581221-0520	ROTOR ASM.;	1	0	:	:	:	:	:	:	:	:	:	:	:	:	1	A	
2	581229-1320	BEARING;BALL	1	0	:	:	:	:	:	:	:	:	:	:	:	:	2	A	
3	982215-8390	RETAINER	1	0	:	:	:	:	:	:	:	:	:	:	:	:	2	A	
4	581224-0020	RING;SLIP	1	0	:	:	:	:	:	:	:	:	:	:	:	:	2	A	
5	581229-0970	COLLER	1	0	:	:	:	:	:	:	:	:	:	:	:	:	2	A	
6	581229-0980	RETAINER	1	0	:	:	:	:	:	:	:	:	:	:	:	:	2	A	
7	581229-1410	BEARING;BALL	1	0	:	:	:	:	:	:	:	:	:	:	:	:	2	A	
8	509503-0640	WASHER	1	0	:	:	:	:	:	:	:	:	:	:	:	:	2	A	
9	581251-0110	REGULATOR	1	0	:	:	:	:	:	:	:	:	:	:	:	:	1	A	
10	581214-1010	BRACKET ASM.;RR.	1	0	:	:	:	:	:	:	:	:	:	:	:	:	1	A	
11	581229-1010	BUSH;INSULATOR	2	0	:	:	:	:	:	:	:	:	:	:	:	:	2	A	
12	581214-0890	BRACKET;RR.	1	0	:	:	:	:	:	:	:	:	:	:	:	:	2	A	
13	581229-1370	TUBE;INSULATOR	1	0	:	:	:	:	:	:	:	:	:	:	:	:	2	A	
14	581219-0270	RECTIFIRE ASM.;	1	0	:	:	:	:	:	:	:	:	:	:	:	:	2	A	
15	581229-1700	BUSH;INSULATOR	2	0	:	:	:	:	:	:	:	:	:	:	:	:	2	A	
16	581229-1430	BOLT; B-TERMINAL	1	0	:	:	:	:	:	:	:	:	:	:	:	:	2	A	
17	581217-0160	HOLDER ASM.;BRUSH	1	0	:	:	:	:	:	:	:	:	:	:	:	:	2	A	
18	581229 1440	TUBE;INSULATOR	1	0	:	:	:	:	:	:	:	:	:	:	:	:	2	A	
19	581229-1480	BOLT; R-TERMINAL	1	0	:	:	:	:	:	:	:	:	:	:	:	:	2	A	
20	581211-0480	STATOR ASM	1	0	:	:	:	:	:	:	:	:	:	:	:	:	1	A	
21	581213-0390	BRACKET;FRT.	1	0	:	:	:	:	:	:	:	:	:	:	:	:	1	A	
22	509000-1770	BOLT	3	0	:	:	:	:	:	:	:	:	:	:	:	:	1	A	
23	581222-0630	PULLEY ASM.;	1	0	:	:	:	:	:	:	:	:	:	:	:	:	1	A	

GENER (NIKKO)

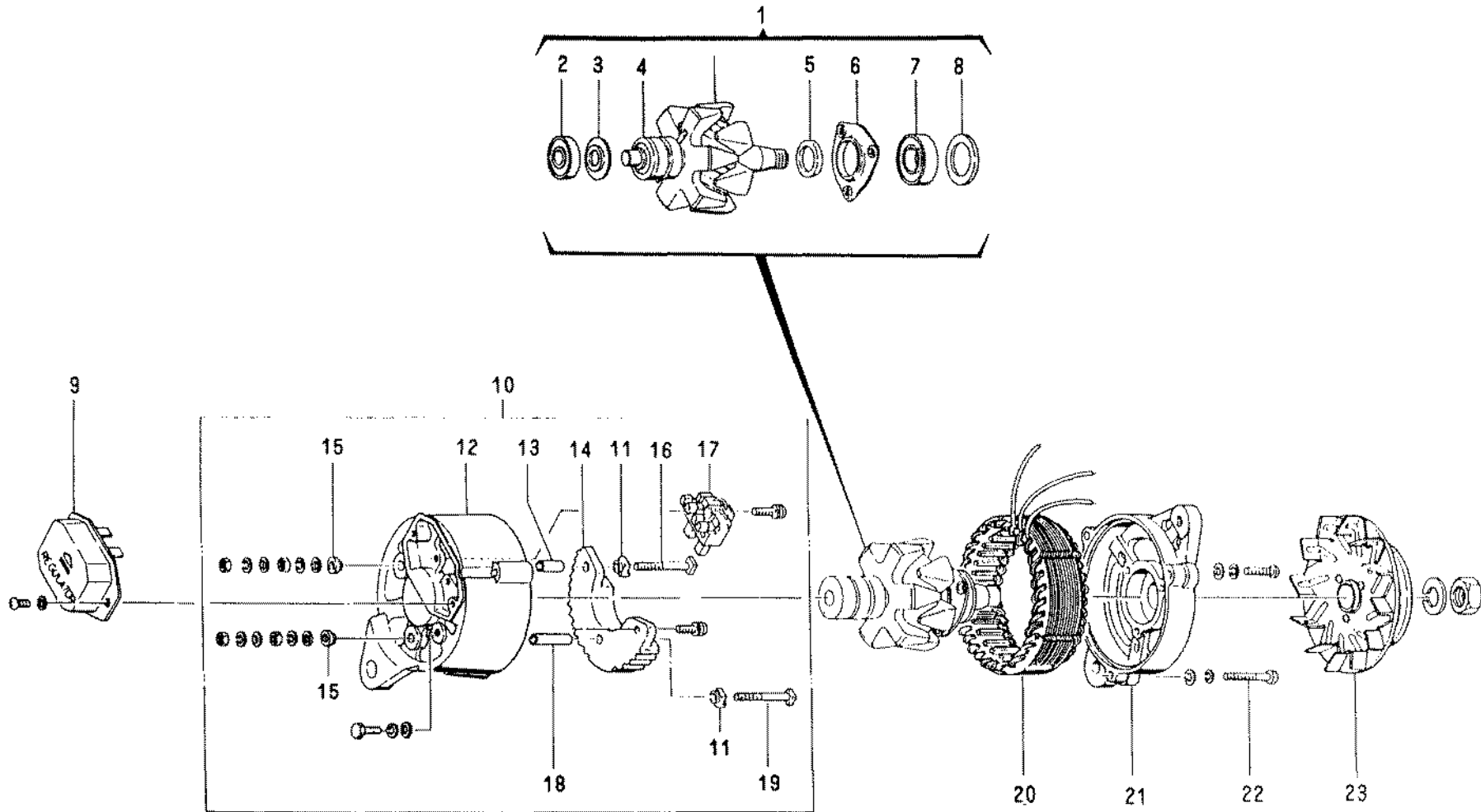

Key No.	Part No.	Part Name	Per Unit	GENERATOR(NIKKO)								L	S · C	I T C	Remarks	NOTE
				00000:00001:11111:11112:22222:22223:	:	:	:	:	:	:	:					
	581200-3000	GENERATOR;12V-35A	1	0	:	:	:	:	:	:	:	:	:			
	581200-3200	GENERATOR;12V-35A	1	0	:	:	:	:	:	:	:	:	:			
1	581221-0550	ROTOR ASM.	1	00	:	:	:	:	:	:	:	:	:	1	A	
2	581229-1680	BEARING,BALL	1	00	:	:	:	:	:	:	:	:	:	2	A	
3	982215-8390	RETAINER	1	00	:	:	:	:	:	:	:	:	:	2	A	
4	581224-0020	RING;SLIP	1	00	:	:	:	:	:	:	:	:	:	2	A	
5	581229-0970	COLLAR	1	00	:	:	:	:	:	:	:	:	:	2	A	
6	581229-0980	RETAINER	1	00	:	:	:	:	:	:	:	:	:	2	A	
7	581229-1670	BEARING;BALL	1	00	:	:	:	:	:	:	:	:	:	2	A	
8	509503-0640	WASHER	1	00	:	:	:	:	:	:	:	:	:	2	A	
9	581251-0130	REGULATOR	1	00	:	:	:	:	:	:	:	:	:	1	A	
10	581214 1120	BRACKET ASM. RR	1	00	:	:	:	:	:	:	:	:	:	1	A	
11	581229-2370	BUSH; INSULATOR	2	00	:	:	:	:	:	:	:	:	:	2	A	
12	581214-1130	BRACKET	1	00	:	:	:	:	:	:	:	:	:	2	A	
13	581229-1720	TUBE; INSULATOR	1	00	:	:	:	:	:	:	:	:	:	2	A	
14	581218-0310	RECTIFIRE ASM.	1	00	:	:	:	:	:	:	:	:	:	2	A	
15	581229-1700	BUSH; INSULATE	2	00	:	:	:	:	:	:	:	:	:	2	A	
16	509000-2390	BOLT	1	0	:	:	:	:	:	:	:	:	:	2	A	
17	581215-0410	HOLDER ASM.;BRUSH	1	00	:	:	:	:	:	:	:	:	:	2	A	
18	581229-1710	TUBU; INSULATE	1	00	:	:	:	:	:	:	:	:	:	2	A	
19	509000-2380	BOLT	1	00	:	:	:	:	:	:	:	:	:	2	A	
20	581211-0660	STATOR ASM.	1	00	:	:	:	:	:	:	:	:	:	1	A	
21	581213-0450	BRACKET ASM.;FRT.	1	00	:	:	:	:	:	:	:	:	:	1	A	
22	509000-2400	BOLT	3	00	:	:	:	:	:	:	:	:	:	1	A	
23	581222-0510	PULLEY ASM.	1	0	:	:	:	:	:	:	:	:	:	1	A	
23 1	581222-0750	PULLEY ASM.	1	0	:	:	:	:	:	:	:	:	:	1	A	

GENERATOR (HITACHI)

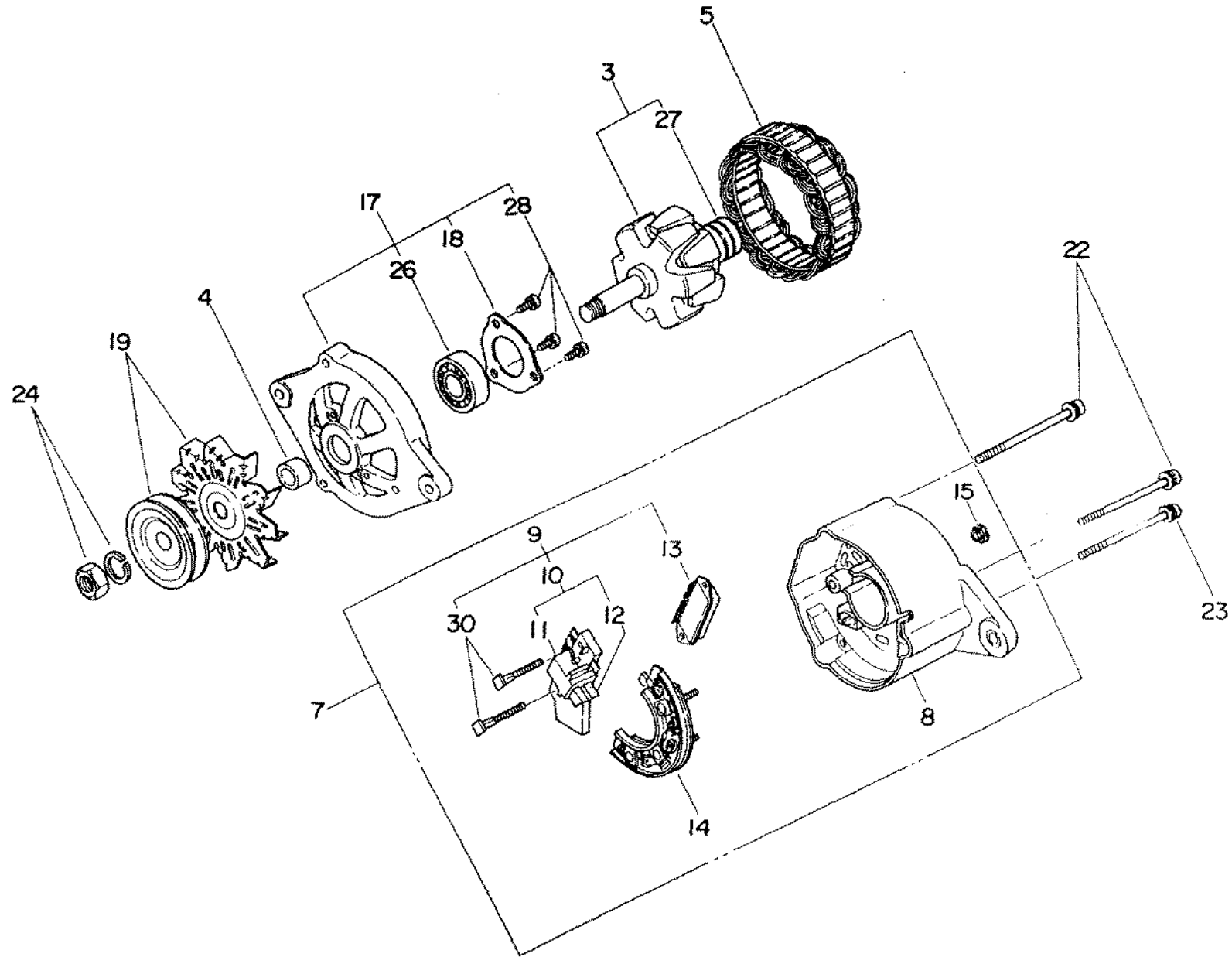

INDEX

ALPHABETICAL

Part Name	Key No.	Part Name	Key No.	Part Name	Key No.
ARM ASM.;ROCKER "C"	9 44	BODY ASM.;AIR CLENER	14 5	BOLT;CASE FIX.	8 25
ARM ASM.;ROCKER "D"	9 46	BODY ASM.;TOP	54B 10	BOLT;CENTER	10 67
ARMATURE ASM.	62 5	BODY;FUEL FILTER	10 62	BOLT;COLLAR FIX.	9 22 1
ARMATURE ASM.	62B 9	BOLT	1 22	BOLT;COLLAR FIX.	9 22 2
ARMATURE ASM.	62C 5	BOLT	4 7	BOLT;CONN.	7 11
ARMATURE ASM.	62D 28	BOLT	12 20 2	BOLT;CONN.	7 11 1
ARMATURE ASM.	62E 4	BOLT	12 20 3	BOLT;COOLING FAN	12 66 2
ARMATURE ASM.	62F 3	BOLT	13 50	BOLT;COVER FIX.	6 14
BAFFLE ASM.;CUP	14 46	BOLT	13 50 1	BOLT;COVER FIX.	6 14
BALL;STAEEL	62 125	BOLT	13 50 2	BOLT;COVER FIX.	6 17
<hr/>					
BALL;STEEL	10 50	BOLT	14 11	BOLT;CRANK, PULLEY	7 33
BALL;STEEL	62C 44	BOLT	18 51 1	BOLT;CRANK, PULLEY	7 42
BAND;INSULATOR	14 10	BOLT	18 55	BOLT;D-6	62F 46
BEARING	52 37	BOLT	52 3	BOLT;EYE	52 53
BEARING	52 38	BOLT	52 23	BOLT;EYE	52 53 1
BEARING SET;CONN.	7 13	BOLT	52 45	BOLT;EYE	54 16
BEARING;BALL	3 32	BOLT	52 49	BOLT;FLYWHEEL	7 24
BEARING;BALL	3 32 1	BOLT	52 49 1	BOLT;GEAR CASE	3 15
BEARING;BALL	62D 15	BOLT	52 65	BOLT;GEAR CASE	3 15 2
BEARING;BALL	62D 27	BOLT	52 93	BOLT;GEAR CASE	3 36
<hr/>					
BEARING;BALL	62D 29	BOLT	52 93 1	BOLT;GEAR CASE	3 36 1
BEARING;BALL	63 5	BOLT	52 94	BOLT;GEAR CASE FIX.	62C 94
BEARING;BALL	63 20	BOLT	52 96	BOLT;GEAR CASE-SWITCH	62 94
BEARING;BALL	63B 2	BOLT	52 120	BOLT;GENERATOR	19 25
BEARING;BALL	63B 7	BOLT	54 10	BOLT;JOINT	11 3
BEARING;BALL	63C 2	BOLT	54 13	BOLT;JOINT,FUEL FILTER	15 32
BEARING;BALL	63C 7	BOLT	62B 26	BOLT;M5	63 11
BEARING;BALL	63E 26	BOLT	62D 7	BOLT;OIL FILTER	10 48 2
BEARING;BALL	63E 27	BOLT	62D 8	BOLT;OIL FILTER	10 48 4
BEARING;BALL (1)	62E 5	BOLT	62E 48	BOLT;OIL FILTER	10 48 5
<hr/>					
BEARING;BALL (2)	62E 6	BOLT	62E 49	BOLT;OIL PAN FIX.	5 15 2
BEARING;BALL (3)	62E 24	BOLT	63B 22	BOLT;OIL PAN FIX.	5 15 3
BEARING;BALL (3)	62E 25	BOLT	63C 16	BOLT;OIL PAN FIX.	5 15 4
BEARING;BALL,RR.	62C 13	BOLT	63C 19	BOLT;OIL PAN FIX.	5 15 5
BEARING;BALL,FRT.	62 12	BOLT	63C 22	BOLT;OIL PAN FIX.	5 15 6
BEARING;BALL,FRT.	62C 12	BOLT	63E 30	BOLT;OIL PAN FIX.	5 15 7
BEARING;BALL,RR.	62 13	BOLT ASM.;TERMINAL	63 31	BOLT;OIL PAN FIX.	5 15 8
BEARING;CONN.UNSI.O.25	7 13 1	BOLT;	9 8	BOLT;OIL PAN FIX.	5 15 9
BEARING;CONN.UNSI.O.5	7 13 2	BOLT;	9 69	BOLT;OIL PAN FIX.	5 15 10
BEARING;GEAR	9 67	BOLT;	12 40 3	BOLT;OIL PAN FIX.	5 23
<hr/>					
BEARING;THRUST	7 2	BOLT;	12 40 6	BOLT;OIL PAN FIX.	5 23 1
BEARING;WATER PUMP	12 6	BOLT;	12 56	BOLT;POINTER FIX.	3 9
BELT;COOLING FAN	12 66	BOLT;	13 65	BOLT;REAMER	2 30
BELT;COOLING FAN	12 66 1	BOLT;	13 65 1	BOLT;REAR,PLATE	2 45
BLADE;LOWER,COOLING FAN	12 62 1	BOLT; B-TERMINAL	63B 16	BOLT;REAR,PLATE FIX.	2 21
BLADE;UPPER,COOLING FAN	12 62	BOLT; R-TERMINAL	63B 19	BOLT;REAR,PLATE FIX.	2 21 1
BLOCK ASM.;CYL.	2 1	BOLT;BRG.CAP FIX.	2 2	BOLT;ROCKER ARM	11 5
BLOCK ASM.;CYL.	2 1 1	BOLT;BRKT.-AIR CLENER	14 32	BOLT;RR.PLATE	2 57
BLOCK ASM.;CYL.	2 1 2	BOLT;BRKT.-MANIFOLD	14 35	BOLT;SEMS	3 4
BODY ASM.;AIR	14 41	BOLT;BRKT.FIX.	9 58	BOLT;SEMS	3 4 1

Part Name	Key No.	Part Name	Key No.	Part Name	Key No.
BOLT; SEMS	4 9	BOLT; THROUGH	63 91	BRUSH; (-)	62F 23
BOLT; SEMS	4 9 1	BOLT; THROUGH	62 85	BRUSH; INSULATOR	63 17
BOLT; SEMS	7 41	BOLT; THROUGH	62C 85	BUSH; CRANK SHAFT	7 16
BOLT; SEMS	9 22	BOLT; THROUGH	62E 46	BUSH; GEAR CASE	3 6
BOLT; SEMS	12 40	BOLT; THROUGH	62F 44	BUSH; GROMMET	3 45
BOLT; SEMS	12 40 1	BOLT; THROUGH	63E 22	BUSH; GUM	62B 12
BOLT; SEMS	12 40 2	BOLT; THROUGH	63E 23	BUSH; INSULATE	63C 15
BOLT; SEMS	12 40 4	BOLT; WATER PUMP FIX.	12 20	BUSH; INSULATOR	63B 11
BOLT; SEMS	12 40 5	BOLT; WATER PUMP FIX.	12 20 1	BUSH; INSULATOR	63B 15
BOLT; SEMS	12 64	BOLT; GEAR CASE	3 15 3	BUSH; INSULATOR	63C 11
-----		-----		-----	
BOLT; SEMS	12 64 1	BRACKET	52 58	BUSH; INSULATOR	63E 15
BOLT; SEMS	12 64 2	BRACKET	52 58 1	BUSH; SMALL END	7 9
BOLT; SEMS	12 64 3	BRACKET	52 119	CAM SHAFT	52 36
BOLT; SEMS	12 64 4	BRACKET	52 119 1	CAM SHAFT	52 36 1
BOLT; SEMS	18 51	BRACKET	63C 12	CAM SHAFT	52 36 2
BOLT; SEMS	18 51 1	BRACKET ASM. RR	63C 10	CAM SHAFT	52 36 3
BOLT; SEMS. OIL PUMP FIX.	6 28	BRACKET ASM.; CENTER	62B 20	CAP	52 57
BOLT; SEMS. ADJ. -PUMP	12 43	BRACKET ASM.; FRT.	62B 16	CAP	54B 12
BOLT; SEMS. ADJ. -PUMP	12 43 1	BRACKET ASM.; FRT.	62D 9	CAP ASM.; CYL. HEAD COVER	1 30
BOLT; SEMS. ADJ. PLATE	19 28	BRACKET ASM.; FRT.	63C 21	CAP NUT	52 105
-----		-----		-----	
BOLT; SEMS. BRKT.	16 22 2	BRACKET ASM.; RR.	62B 25	CAP; RUBBER	62C 83
BOLT; SEMS. BRKT. -PLATE	18 51	BRACKET ASM.; RR.	63B 10	CAP; RUBBER NOZZLE LEAKE	15 37
BOLT; SEMS. BRKT. ENG. FOOT	16 22 1	BRACKET; CENTER	62D 14	CAPSULE; SPR.	52 107 2
BOLT; SEMS. BRKT. FIX.	16 22	BRACKET; CENTER	62D 20	CAPSULE; SPRING	52 77
BOLT; SEMS. COLLER FIX.	9 22 1	BRACKET; FRONT AIR CLENER	14 30	CAPSULE; SPRING	52 77 1
BOLT; SEMS. COVER FIX.	3 46	BRACKET; FRT.	63B 21	CAPSULE; SPRING	52 77 2
BOLT; SEMS. COVER FIX.	6 17 1	BRACKET; GENERATOR	16 20	CAPSULE; SPRING	52 77 3
BOLT; SEMS. COVER FIX.	10 85	BRACKET; GENERATOR	16 20 1	CARTRIDGE; OIL FILTER	10 2
BOLT; SEMS. FRT.	16 48	BRACKET; GENERATOR	16 20 2	CARTRIDGE; OIL FILTER	10 2 1
BOLT; SEMS. FRT. PLATE	2 55	BRACKET; GENERATOR	16 20 3	CARTRIDGE; OIL FILTER	10 2
-----		-----		-----	
BOLT; SEMS. FRT. PLATE	2 55 1	BRACKET; INJ. PUMP	18 38	CARTRIDGE; OIL FILTER	10 2 1
BOLT; SEMS. GEAR CASE	3 15 1	BRACKET; INJ. PUMP	18 38 1	CASE ASM.; GEAR	62 65
BOLT; SEMS. GEAR CASE	3 34	BRACKET; REAR, AIR CLENER	14 31	CASE ASM.; GEAR	62C 65
BOLT; SEMS. GEAR CASE	3 34 1	BRACKET; RR.	62D 24	CASE ASM.; GEAR	62F 28
BOLT; SEMS. GENERATOR	19 25	BRACKET; RR.	63B 12	CASE; CRANK	5 27
BOLT; SEMS. HANGER FIX.	16 17	BRACKET	52 109	CASE; CRANK	5 27 1
BOLT; SEMS. INLET PIPE	13 74	BRACKET; ROCKER ARM	9 55	CASE; GEAR, TIMING	3 1
BOLT; SEMS. LH	16 50	BREATHER ASM.; AIR	52 100	CASE; GEAR, TIMING	3 1 1
BOLT; SEMS. OIL FILTER	10 48	BRG.; BALL, FLYWHEEL	7 36	CASE; GEAR, TIMING	3 1 2
BOLT; SEMS. OIL FILTER	10 48 1	BRG. KIT; CRANK, STD.	7 1	CASE; GEAR, TIMING	3 1 3
-----		-----		-----	
BOLT; SEMS. OIL FILTER	10 48 3	BRG. KIT; CRANK, UNSI. 0.50	7 1 1	CASE; OIL STRAINER	6 21
BOLT; SEMS. OIL PAN FIX.	5 15	BRG. KIT; CRANK, UNSI. 1.00	7 1 2	CASE; OIL STRINER	6 21
BOLT; SEMS. OIL PAN FIX.	5 15 1	BRUSH	63 15	CENTER; FAN, WATER PUMP	12 15
BOLT; SEMS. OUTLET PIPE	12 58	BRUSH	63E 12	CENTER; FAN, WATER PUMP	12 15 1
BOLT; SEMS. RH	16 49	BRUSH (+)	62E 11	CENTER; FAN, WATER PUMP	12 15
BOLT; SEMS. THRUST PLATE	9 12	BRUSH (-)	62E 17	CLAMP ASM.	14 47
BOLT; SOCKET	9 71	BRUSH ASM.	62B 11	CLEANER ASM.; AIR	14
BOLT; STARTER FIX.	19 42	BRUSH ASM.	63 13	CLEANER ASM.; AIR	14 40
BOLT; STARTER FIX.	19 42 1	BRUSH ASM.	63E 10	CLIP	52 64
BOLT; THROUGH	63 90	BRUSH (+)	62F 17	CLIP	62E 29

Part Name	Key No.	Part Name	Key No.	Part Name	Key No.
CLIP ASM. ;	15 20	COVER ASM. ; HEAD COVER	1 50	DUST COVER ; (A)	62F 32
CLIP ASM. ; FUEL PIPE	15 45	COVER ASM. ; REAR	62E 13	DUST COVER ; (B)	62F 33
CLIP RING	62B 5	COVER ASM. ; REAR	62F 19	DUST COVER ; (C)	62F 34
CLIP ; HOSE	5 41	COVER ASM. ; REAR	63E 7	DUST COVER ; (D)	62F 35
CLIP ; HOSE	15 43	COVER ASM. ; REAR	63E 7 1	ELEMENT ASM.	14 43
CLIP ; HOSE	15 43 1	COVER ASM. ; RR.	62C 30	ELEMENT ASM. ;	10 72
CLIP ; HOSE	15 43 2	COVER ASM. ; RR.	63 7	ELEMENT ASM. ; AIR CLENER	14 15
CLIP ; NOZZLE LEAKE OFF	15 43 3	COVER ASM. ; W/RELIEF VLV.	10 6	EYE	54 18
CLIP ; PINION	62F 12	COVER ASM. ; W/RELIEF VLV.	10 6 1	EYE	54 18 1
CLIP ; SHUTTER	13 64 1	COVER ASM. ; W/RELIEF VLV.	10 6 2	EYE	58 20
CLIP ; SHUTTER	13 64 2	COVER ASM. ; GEAR CASE	3 41	EYE ; SPR. PUMP. CONT.	18 59
CLIP ; SHUTTER, RETURN	13 64	COVER KIT ; DUST	62E 39	EYE ; SPRING, SHUTTER	13 66
CLUTCH ASM.	62E 23	COVER ; A. GEAR CASE	3 2 1	EYE ; SPRING, SHUTTER	13 66 1
CLUTCH ASM. ; PINION	62 55	COVER ; B. GEAR CASE	3 2 2	FAN ASM.	12 62 3
CLUTCH ASM. ; PINION	62B 19	COVER ; B. GEAR CASE	3 2 3	FAN ASM.	12 62 4
CLUTCH ASM. ; PINION	62D 13	COVER ; BOTTOME	54B 1	FAN ASM. ;	12 62 4
CLUTCH ASM. ; PINION	62E 21	COVER ; DUST (B)	62E 41	FAN ASM. ;	12 62 5
CLUTCH ; PINION	62C 55	COVER ; DUST (C)	62E 42	FILTER ASM. ; FUEL	10 60
COIL ASM. ; FIELD	62D 30	COVER ; DUST (D)	62E 43	FILTER ASM. ; OIL	10 1
COIL ASM. ; FIELD	62B 10	COVER ; DUST (E)	62E 44	FILTER ASM. ; OIL	10 1 1
COIL ASM. ; FIELD	62E 9	COVER ; DUST (R)	62E 40	FILTER ASM. ; OIL	10 1 2
COIL ASM. ; FIELD	62F 15	COVER ; FRONT, GEAR CASE	3 21 2	FLYWEIGHT ASM	52 85
COLLAR	52 111	COVER ; FUEL FILTER	10 64	FLYWHEEL ASM. ;	7 19
COLLAR	52 115	COVER ; GEAR CASE	3 2	FLYWHEEL ASM. ;	7 19 1
COLLAR	63C 5	COVER ; GEAR CASE	3 2 4	FLYWHEEL ASM. ;	7 19 2
COLLAR ; IDLE GEAR	9 70	COVER ; GEAR CASE	3 21	FLYWHEEL ASM. ;	7 19 3
COLLAR ; SPLIT	9 35	COVER ; GEAR CASE	3 21 1	FLYWHEEL ASM. ;	7 19 4
COLLAR ; THRUST	9 20	COVER ; OIL PUMP	6 13	FLYWHEEL ASM.	7 19
COLLER	63B 5	COVER ; OIL PUMP	6 13 1	FOOT ; ENG. FRT. LH	16 47
CONNECTOR	19 12	COVER ; REAR	63E 8	FOOT ; ENG. FRT. LH	16 47 1
COUPLING	52 47	COVER ; REAR	63E 8 1	FOOT ; ENG. FRT. RH	16 46
COUPLING	52 47 1	COVER ; RR.	63 8	FOOT ; ENG. FRT. RH	16 46 1
COUPLING	52 47 2	COVER ; WATER PUMP	12 17	GASKET	52 18
COUPLING	52 47 3	COVER ; WATER PUMP	12 17 1	GASKET	52 54
COUPLING ASM.	52 46	COVER ; WATER PUMP	12 17 2	GASKET	52 54 1
COUPLING ASM.	52 46 1	CRANK SHAFT ASM.	7 14	GASKET	52 56
COVER	52 5	CRANK SHAFT ASM.	7 14 1	GASKET	52 81
COVER	52 5 1	CRANK SHAFT ASM.	7 14 2	GASKET	52 91
COVER	52 8	CUP ; SEALING, DRILLED PASS	1 3 3	GASKET	52 99
COVER	52 8 1	CUP ; SEALING, L-SIDE	2 6 1	GASKET	52 103
COVER	52 44	CUP ; SEALING, REAR	2 6	GASKET	54 15
COVER	52 92	CUP ; SEALING, REAR, FASE	1 3	GASKET	54 21
COVER	54 2	CUP ; SEALING, REAR, FASE	1 3 1	GASKET ;	52 4
COVER ASM. ;	14 17	CUP ; SEALING, REAR, FASE	1 3 2	GASKET ; CYL. HEAD	1 21
COVER ASM. ; CYL. HEAD	1 29	DIAPHRAGM	54 7	GASKET ; CYL. HEAD	1 21 1
COVER ASM. ; CYL. HEAD	1 29 1	DIAPHRAGM	54B 5	GASKET ; EXH. PIPE	13 75
COVER ASM. ; CYL. HEAD	1 29 2	DIODE ASM.	63 16	GASKET ; INLET, EXH. MANI.	13 46
COVER ASM. ; FRONT	63E 17	DIODE ASM.	63E 14	GASKET ; PLUG	4 6
COVER ASM. ; FRONT	63E 17 1	DOWEL ;	2 40	GASKET ; WATER PUMP	12 12
COVER ASM. ; FRT.	63 18	DRAIN PIPE ; WATER	2 35	GASKET ; WATER PUMP	12 12 1

Part Name	Key No.	Part Name	Key No.	Part Name	Key No.
GAUGE ASM.; OIL	5 18	HOLDER ASM.; BRUSH	62 33	MANIFOLD; INLET	13 1 2
GAUGE ASM.; OIL	5 18 1	HOLDER ASM.; BRUSH	62B 24	METAL	62D 10
GAUZE; OIL STRAINER	6 20	HOLDER ASM.; BRUSH	62C 33	METAL; CENTER	62B 21
GEAR	52 48	HOLDER ASM.; BRUSH	62D 23	METAL; FRT. AND RR.	62B 17
GEAR	52 48 1	HOLDER ASM.; BRUSH	62E 15	METAL; GEAR CASE	62F 29
GEAR CASE	62E 31	HOLDER ASM.; BRUSH	62F 22	METAL; REAR COVER	62F 20
GEAR; CAM	9 6	HOLDER ASM.; BRUSH	63B 17	NIPPLE; DRAIN OIL PAN	5 35
GEAR; CAM	9 6 1	HOLDER ASM.; BRUSH	63C 17	NIPPLE; ROCKER, OIL FEED	2 13
GEAR; CAM	9 6 2	HOLDER ASM.; NOZZLE	58	NOZZLE; FUEL, INJ.	15 2
GEAR; CAM	9 6 3	HOLDER ASM.; NOZZLE, FIG. 58	15 3	NUT	3 25
-----		-----		-----	
GEAR; CRANK SHAFT	7 25	HOLDER; BRUSH	63 14	NUT	3 25 1
GEAR; HYDRAULIC, PUMP DRIVE	3 30	HOLDER; BRUSH	63E 11	NUT	3 25 2
GEAR; HYDRAULIC, PUMP DRIVE	3 30 1	HOLDER; DELIVERY	52 19	NUT	3 25 3
GEAR; IDLE	62 121	HOSE; RUBBER	15 42	NUT	3 25 4
GEAR; IDLE	62C 40	HOSE; RUBBER	15 42 1	NUT	7 12
GEAR; IDLE CAM-INJ. PUMP	9 65	HOSE; RUBBER	15 42 2	NUT	12 23
GEAR; INJ. PUMP	18 42	HOSE; RUBBER OILPAN-NIPPLE	5 40	NUT	13 68
GEAR; INJ. PUMP	18 42 1	HOSE; RUBBER, NOZZLE LEAKE	15 35	NUT	13 76
GEAR; PINION	62 120	HOUSING; CENTER	62E 19	NUT	14 12
GEAR; RING	7 20	HOUSING; FEED PUMP	54 1	NUT	52 11
-----		-----		-----	
GEAR; W/ BUSH	9 18	HOUSING; FLYWHEEL	4 1	NUT	52 22
GENERATOR ASM.;	63B	HOUSING; PUMP	52 1	NUT	52 51
GENERATOR ASM.;	63E	HOUSING; PUMP	52 1 1	NUT	52 51 1
GENERATOR ASM.; FIG. 63	19 2	HOUSING; PUMP	52 1 2	NUT	52 87
GENERATOR ASM.; FIG. 63	19 2 1	HOUSING; PUMP	52 1 3	NUT	52 87 1
GENERATOR ASM.; FIG. 63	19 2 2	INDICATOR; SERVICE	14 42	NUT	52 98
GENERATOR ASM.; FIG. 63B	19 2 1	INSULATOR	14 8	NUT	52 104
GENERATOR ASM.; FIG. 63C	19 2 1	KEY	52 52	NUT	52 108
GENERATOR ASM.; FIG. 63C	19 2 2	KEY; FEATHER	7 23	NUT	52 108 1
GENERATOR ASM.; FIG. 63E	19 2 3	KEY; FEATHER	9 7	NUT	52 122
-----		-----		-----	
GENERATOR ASM.; 12V-20A	63	LEVER	52 67	NUT	58 24
GENERATOR ASM.; 12V-35A	63E	LEVER	52 67 1	NUT	62B 2
GENERATOR; 12V-35A	63C	LEVER	52 67 2	NUT	62C 81
GROMMET	1 52	LEVER	52 110	NUT	62D 3
GROMMET	1 53	LEVER	54 30	NUT ASM.	14 44
GROMMET	3 44	LEVER ASM.	54B 8	NUT ASM.; PULLEY	63 80
GUID TUBE; WATER PIPE	12 35	LEVER ASM.; SHIFT	62B 3	NUT;	18 56
GUIDE	52 26	LEVER ASM.; SHIFT	62D 2	NUT; STARTER FIX.	19 43
GUIDE SCREW	52 102	LEVER KIT; SHIFT	62F 37	NUT; STARTER FIX.	19 43 1
GUIDE; VALVE, EXH.	1 9 1	LEVER SET; SHIFT	62E 33	NUT; ADJ. SCREW	9 52
-----		-----		-----	
GUIDE; VALVE, INLET	1 9	LEVER; GUIDE	52 78	NUT; COVER	1 57
HANGER; FRONT	16 11	LEVER; SHIFT	62E 34	NUT; GENERATOR	19 26
HANGER; FRONT	16 11 1	LEVER; TENSION	52 76	NUT; HEAD COVER	1 35
HANGER; REAR	16 15 1	LEVER; TENSION	52 76 1	NUT; LOCK	52 95
HANGER; REAR	16 15 2	MANIFOLD; EXH.	13 20	NUT; PULLEY	63E 24
HANGER; REAR	16 15 3	MANIFOLD; EXH.	13 20 1	NUT; REAMER	2 47
HEAD ASM.; CYL.	1 1	MANIFOLD; EXH.	13 20 2	NUT; REAMER BOLT	4 10
HEAD ASM.; CYL.	1 1 1	MANIFOLD; EXH.	13 20 3	NUT; RETAINING	58 16
HEAD ASM.; CYL.	1 1 2	MANIFOLD; INLET	13 1	NUT; ROCKER ARM, BRKT. FIX.	9 61
HEAT SHIELD; NOZZLE	15 6	MANIFOLD; INLET	13 1 1	NUT; WING	14 21

Part Name	Key No.	Part Name	Key No.	Part Name	Key No.
O-RING	52 12	PACKING; OIL FILTER-CYL.	10 45	PIPE ASM.; INJ. NO. 3	15 17
O-RING	52 59	PACKING; OUTLET PIPE	12 57	PIPE ASM.; INJ. NO. 3	15 17 1
O-RING	52 69	PACKING; PLUG	1 61	PIPE ASM.; INJ. PUMP-FILTER	15 25
O-RING	54 31	PACKING; PLUG	12 31	PIPE ASM.; OIL PUMP	11 1
OIL SEAL	52 43	PACKING; PUMP-CYL. BLOCK	12 32	PIPE ASM.; OIL, ROCKER	11 2
PACKIN; GEAR CASE	3 5	PACKING; PUMP-CYL. HEAD	12 34	PIPE ASM.; OIL, ROCKER	11 2 1
PACKING	5 20	PACKING; PUMP-CYL. HEAD	12 34 1	PIPE ASM.; WATER	12 51
PACKING	10 82	PACKING; SHUTTER	13 62	PIPE ASM.; WATER OUTLET	12 50
PACKING	54B 11	PACKING; SHUTTER	13 62 1	PIPE ASM.; WATER OUTLET	12 50 1
PACKING	62B 18	PACKING; SPACER	3 40	PIPE ASM; FUEL INJ. PUMP	15 44
PACKING ASM.; WING NUT	14 20	PACKING; YOKE-SWITCH	62 113	PIPE ASM; INJ. NO. 3	15 17 1
PACKING; BODY-COVER	10 65	PAN ASM.; OIL	5 1 1	PIPE; INLET	13 72
PACKING; BRKT.-PLATE	18 50	PAN ASM.; OIL	5 1 2	PIPE; INLET	13 72 1
PACKING; BRKT.-PLATE	18 50 1	PAN ASM.; OIL	5 1 3	PIPE; INLET	13 72 2
PACKING; COVER	14 7	PAN ASM.; OIL	5 1 4	PIPE; VINYL, INJ. LEAKE OFF	15 28
PACKING; COVER. A	3 3 1	PAN; OIL W/OIL FILLER	5 1	PIPE; VINYL, INJ. LEAKE OFF	15 28 1
PACKING; COVER. B	3 3 2	PIN	52 24	PISTON	54B 3
PACKING; COVER. B	3 3 3	PIN	52 80	PISTON; OVSI. 0.50	7 3
PACKING; COVER WATER PIPE	12 59	PIN	54 4	PISTON; OVSI. 0.50	7 3 1
PACKING; CYL. HEAD COVER	1 32	PIN	54B 6	PISTON; OVSI. 1.00	7 3
PACKING; ELEMENT	10 74	PIN	54B 9	PISTON; OVSI. 1.00	7 3 1
PACKING; ELEMENT	14 6	PIN;	7 40	PISTON; STD.	7 3
PACKING; ELEMENT	14 18	PIN; LEVER	62B 1	PISTON; STD.	7 3 1
PACKING; FRT. CYL. PLATE	2 52	PIN; LEVER	62D 1	PLATE	52 20
PACKING; FRT. CYL. PLATE	2 52 1	PIN; PINION-SHAFT	6 8	PLATE	62D 4
PACKING; FRT. CYL. PLATE	2 52 2	PIN; PISTON	7 6	PLATE; ADJ. FAN BELT	12 45
PACKING; GEAR CASE	3 5 1	PIN; ROTER-SHAFT	6 10	PLATE; ADJ. FAN BELT	12 45
PACKING; GEAR CASE	3 5 2	PIN; SPLIT	52 118	PLATE; ADJ. FAN BELT	12 45 1
PACKING; GEAR CASE	3 48	PIN; STRAIGHT	2 28	PLATE; ADJ. FAN BELT	12 45 2
PACKING; GEAR CASE COVER	3 3	PIN; STRAIGHT	2 28 1	PLATE; FRT. CYL. BLOCK	2 50
PACKING; GEAR CASE COVER	3 3 4	PIN; STRAIGHT	2 28 2	PLATE; FRT. CYL. BLOCK	2 50 1
PACKING; GEAR CASE COVER	3 22	PIN; STRAIGHT	2 53	PLATE; FRT. CYL. BLOCK	2 50 2
PACKING; GEAR CASE FRONT	3 22 1	PIN; STRAIGHT	2 53 1	PLATE; FRT. CYL. BLOCK	2 50 3
PACKING; GEAR CASE O-RING	3 33	PIN; STRAIGHT	2 58	PLATE; REAR, CYL. BLOCK	2 20
PACKING; GEAR CASE O-RING	3 33 1	PIN; STRAIGHT	7 17	PLATE; REAR, CYL. BLOCK	2 20 1
PACKING; INLET-MANIF.	13 73	PIN; STRAIGHT	7 21	PLATE; REAR, CYL. BLOCK	2 20 2
PACKING; JOINT BOLT	11 4	PIN; STRAIGHT	7 37	PLATE; REAR, CYL. BLOCK	2 20 3
PACKING; JOINT BOLT	15 33	PIN; STRAIGHT, CRANK CASE	5 28	PLATE; TERMINAL	63 12
PACKING; O-RING	5 6	PIN; STRAIGHT, CRANK CASE	5 28 1	PLATE; THRUST	9 21
PACKING; O-RING	5 38	PINION	52 32	PLATE; THRUST, CAM SHAFT	9 11
PACKING; O-RING	10 38	PINION ASM.	62F 26	PLUG	52 55
PACKING; O-RING	10 38 1	PINION STOPPER	62F 11	PLUG	52 82
PACKING; O-RING	10 45 1	PINION; OIL, PUMP DRIVE	6 7	PLUG ASM.; HOT	1 14
PACKING; O-RING	10 70	PIPE	52 63	PLUG;	10 39
PACKING; O-RING	18 45	PIPE	52 121	PLUG;	10 39 1
PACKING; O-RING, CYL. HEAD	1 49	PIPE ASM.; FILTER-INJ.	15 30	PLUG; DRAIN	5 5
PACKING; OIL PAN-BRG. CASE	5 29	PIPE ASM.; INJ. NO. 1	15 15	PLUG; DRAIN NIPPLE	5 37
PACKING; OIL PAN-CYL. BLOCK	5 10	PIPE ASM.; INJ. NO. 1	15 15 1	PLUG; GLOW, SHEATHED TYPE	19 10
PACKING; OIL PAN-CYL. BLOCK	5 10 1	PIPE ASM.; INJ. NO. 2	15 16	PLUG; GLOW, SHEATHED TYPE	19 10 1
PACKING; OIL PAN-CYL. BLOCK	5 10 2	PIPE ASM.; INJ. NO. 2	15 16 1	PLUG; PLATE, CAM BRG.	2 9

Part Name	Key No.	Part Name	Key No.	Part Name	Key No.
PLUG; PLATE, CYL. HEAD	1 15	PUMP ASM.; INJ. FIG. 52	18 5 3	RING; SLIP	63B 4
PLUG; PLATE, OIL GALLERY	2 10	PUMP ASM.; INJ. FIG. 52	18 5 4	RING; SLIP	63C 4
PLUG; PLATE, TAPPET, CHAMBER	2 12	PUMP ASM.; INJ. FIG. 52	18 5 5	RING; SNAP	7 7
PLUG; ROCKER ARM SHAFT	9 54	PUMP ASM.; INJ. FIG. 52	18 5 6	RING; SNAP	9 57
PLUG; SCREW	1 60	PUMP ASM.; INJ. FIG. 52	18 5 7	RING; SNAP	54 32
PLUG; SCREW	4 5	PUMP ASM.; INJ. FIG. 52	18 5 8	ROD ASM.; CONN.	7 8
PLUG; THERMOMETER	12 30 2	PUMP ASM.; INJ. FIG. 52	18 5 9	ROD ASM.; CONN.	7 8 1
PLUG; WATER, DRAIN	2 36	PUMP ASM.; INJ. FIG. 52	18 5 10	ROD; PUSH	9 40
PLUG; 1/2 TAPPET CHAMBER	2 8	PUMP ASM.; INJ. FIG. 52	18 5 11	ROD; PUSH	58 1
PLUG; 1/2, UPPER, FASE	1 10	PUMP ASM.; INJ. WO/ FEEDPUMP	52 3	ROLLER	52 25
PLUG; 1/8, TAPER, OIL GALLER	2 11	PUMP ASM.; INJ. WO/ FEEDPUMP	52 7	ROLLER	62 122
PLUG; 1/8, TAPER, OIL GALLER	2 11 1	PUMP ASM.; INJ. WO/ FEEDPUMP	52 8	ROLLER	62C 41
PLUG; 3/8 HEATER	12 30	PUMP ASM.; OIL, W/ STRAINER	6 1	ROTOR ASM.	63 3
PLUG; 3/8 HEATER	12 30 1	PUMP ASM.; OIL, W/ STRAINER	6 1 1	ROTOR ASM.	63C 1
PLUNGER ASM.	52 15	PUMP ASM.; WATER, W/ THERMO	12 1	ROTOR ASM.	63E 3
POINTER; TIMING, GEAR CASE	3 8	PUMP ASM.; WATER, W/ THERMO	12 1 1	ROTOR ASM.;	63B 1
POINTER; TIMING, GEAR CASE	3 8 1	PUMP ASM.; WATER, W/ THERMO	12 1 2	ROTOR SET;	6 2
PULLEY ASM.	63 75	RACK; CONTROL	52 30	ROTOR; OIL PUMP	6 9
PULLEY ASM.	63C 23	RACK; CONTROL	52 30 1	POTOR; WATER PUMP	12 10
PULLEY ASM.	63C 23 1	RECTIFIRE ASM.	63C 14	RUBBER; MTG.	1 56
PULLEY ASM.	63E 19	RECTIFIRE ASM.;	63B 14	RUBBER; SEAL	1 54
PULLE; ASM.	63E 19 1	REGULATOR	63B 9	RUBBER; SEAL, COVER	3 42
PULLEY ASM.;	63B 23	REGULATOR	63C 9	RUBBER; SEAL, COVER	3 43
PULLEY BOSS; CRANK	7 38	REGULATOR ASM.; BRUSH	63 9	SAFETY RELAY; STARTER	19 45
PULLEY; COOLING FAN	12 60	REGULATOR ASM.; BRUSH	63E 9	SCREW	10 80
PULLEY; COOLING FAN	12 60 1	REGULATOR ASM.; IC	63 10	SCREW	52 6
PULLEY; COOLING FAN	12 60 2	REGURATOR ASM.; I. C	63E 13	SCREW	52 14
PULLEY; COOLING FAN	12 60 3	REPAIR KIT; WATER PUMP	12 4	SCREW	52 31
PULLEY; CRANK SHAFT	7 30	REPAIR KIT; WATER PUMP	12 4 1	SCREW	52 35
PULLEY; CRANK SHAFT	7 30 1	RESISTANCE	19 20	SCREW	52 73
PULLEY; CRANK SHAFT	7 30 2	RESISTANCE	19 20 1	SCREW	52 97
PULLEY; CRANK SHAFT	7 30 3	RETAINER	54 9	SCREW	52 97 1
PUMP ASM.; FEED	54	RETAINER	62 123	SCREW	52 97 2
PUMP ASM.; FEED	54B	RETAINER	62C 42	SCREW	52 107
PUMP ASM.; FEED, FIG. 54	18 20 1	RETAINER	63B 3	SCREW	52 107 1
PUMP ASM.; FEED, FIG. 54B	18 20	RETAINER	63B 6	SCREW	54B 13
PUMP ASM.; INJ.	52	RETAINER	63C 3	SCREW	62D 6
PUMP ASM.; INJ.	52 1	RETAINER	63C 6	SCREW	62D 25
PUMP ASM.; INJ.	52 2	RETAINER; BRG.	63 19	SCREW	62E 47
PUMP ASM.; INJ.	52 3	RETAINER; BRG.	63E 18	SCREW	62F 49
PUMP ASM.; INJ.	52 4	RING	52 39	SCREW KIT	63 21
PUMP ASM.; INJ.	52 5	RING	52 40	SCREW KIT	63E 28
PUMP ASM.; INJ.	52 6	RING SET; PISTON, OVS I. 0.50	7 4 1	SCREW SET; POLE CORE	62F 16
PUMP ASM.; INJ.	52 7	RING SET; PISTON, OVS I. 1.00	7 4 2	SCREW; ADJ.	9 50
PUMP ASM.; INJ.	52 9	RING SET; PISTON, STD.	7 4	SCREW; DISH	62B 22
PUMP ASM.; INJ.	52 10	RING;	62F 8	SCREW; DISH	62D 21
PUMP ASM.; INJ.	52 11	RING; CLIP	62D 11	SCREW; SEMS	62C 82
PUMP ASM.; INJ. FIG. 52	18 5	RING; SEAL	52 13	SDREW; POLE CORE	62E 10
PUMP ASM.; INJ. FIG. 52	18 5 1	RING; SEAL	52 13 1	SEAL ASM.;	62D 31
PUMP ASM.; INJ. FIG. 52	18 5 2	RING; SEALING, VALVE	9 33	SEAL RING	52 7

Part Name	Key No.	Part Name	Key No.	Part Name	Key No.
SEAL RING	52 7 1	SHIM	52 70	SHIM; T=1.26	58 8
SEAL SET; WATER PUMP	12 8	SHIM	52 70 1	SHIM; T=1.28	58 8
SEAL; OIL	3 19	SHIM	52 83	SHIM; T=1.30	58 8
SEAL; OIL	52 114	SHIM	52 83 1	SHIM; T=1.32	58 8
SEAL; OIL; CRANK SHAFT	2 25	SHIM	52 83 2	SHIM; T=1.34	58 8
SEAL; VALVE	1 11	SHIM	52 83 3	SHIM; T=1.36	58 8
SEAT ASM.; SPR.	9 32	SHIM	52 83 4	SHIM; T=1.38	58 8
SEAT; SPR.	10 78	SHIM	52 83 5	SHIM; T=1.40	58 8
SEAT; SPRING	52 28	SHIM	52 83 6	SHIM; T=1.42	58 8
SEAT; SPRING	52 29	SHIM	52 83 7	SHIM; T=1.44	58 8
SEAT; SPRING	52 88	SHIM	52 90 2	SHIM; T=1.46	58 8
SEAT; VALVE, INSERT, EXH.	1 8	SHIM	52 90 3	SHIM; T=1.48	58 8
SEAT; VALVE, INSERT, INLET	1 7	SHIM; T=0.50	58 8	SHIM; T=1.50	58 8
SHAFT	9 66	SHIM; T=0.52	58 8	SHIM; T=1.52	58 8
SHAFT	9 66 1	SHIM; T=0.54	58 8	SHIM; T=1.54	58 8
SHAFT	52 68	SHIM; T=0.56	58 8	SHUTTER ASM.; INTAKE	13 60
SHAFT	52 106	SHIM; T=0.58	58 8	SHUTTER ASM.; INTAKE	13 60 1
SHAFT	52 116	SHIM; T=0.60	58 8	SLEEVE	52 84
SHAFT ASM.	62D 16	SHIM; T=0.62	58 8	SLEEVE; CONTROL	52 33
SHAFT; CAM	9 1	SHIM; T=0.64	58 8	SLEEVE; CONTROL	52 34
SHAFT; CAM	9 1 1	SHIM; T=0.66	58 8	SPACER	52 79
SHAFT; DRIVE GEAR	3 31	SHIM; T=0.68	58 8	SPACER	58 12
SHAFT; DRIVE GEAR	3 31 1	SHIM; T=0.70	58 8	SPACER	63 4
SHAFT; IDLE GEAR, CYL. BLOCK	9 15	SHIM; T=0.72	58 8	SPACER	63E 4
SHAFT; IDLE GEAR, CYL. BLOCK	9 15 1	SHIM; T=0.74	58 8	SPACER; CRANK, PULLEY	7 35
SHAFT; IDLE GEAR, CYL. BLOCK	9 15 2	SHIM; T=0.76	58 8	SPACER; FAN	12 63
SHAFT; OIL, PUMP DRIVE	6 6	SHIM; T=0.78	58 8	SPACER; FAN	12 63 1
SHAFT; PINION	62E 22	SHIM; T=0.80	58 8	SPACER; FAN	12 63 2
SHAFT; ROCKER ARM	9 53	SHIM; T=0.82	58 8	SPACER; GROMMET	1 55
SHIM	52 41	SHIM; T=0.84	58 8	SPACER; HYDRAULIC	3 38
SHIM	52 41 1	SHIM; T=0.86	58 8	SPACER; OIL FILLER	5 30
SHIM	52 41 2	SHIM; T=0.88	58 8	SPRING	10 46
SHIM	52 41 3	SHIM; T=0.90	58 8	SPRING	52 17
SHIM	52 41 4	SHIM; T=0.92	58 8	SPRING	52 89
SHIM	52 41 5	SHIM; T=0.94	58 8	SPRING	52 89 1
SHIM	52 41 6	SHIM; T=0.96	58 8	SPRING	52 101
SHIM	52 41 7	SHIM; T=0.98	58 8	SPRING	52 101 1
SHIM	52 41 8	SHIM; T=1.00	58 8	SPRING	52 112
SHIM	52 41 9	SHIM; T=1.02	58 8	SPRING	54 5
SHIM	52 41 10	SHIM; T=1.04	58 8	SPRING	54 6
SHIM	52 42	SHIM; T=1.06	58 8	SPRING	54 33
SHIM	52 42 1	SHIM; T=1.08	58 8	SPRING	54B 4
SHIM	52 42 2	SHIM; T=1.10	58 8	SPRING	54B 7
SHIM	52 42 3	SHIM; T=1.12	58 8	SPRING; ELEMENT	10 76
SHIM	52 42 4	SHIM; T=1.14	58 8	SPRING; BRUSH	62 35
SHIM	52 42 5	SHIM; T=1.16	58 8	SPRING; BRUSH	62B 23
SHIM	52 42 6	SHIM; T=1.18	58 8	SPRING; BRUSH	62C 35
SHIM	52 42 7	SHIM; T=1.20	58 8	SPRING; BRUSH	62D 22
SHIM	52 42 8	SHIM; T=1.22	58 8	SPRING; BRUSH	62E 16
SHIM	52 42 9	SHIM; T=1.24	58 8	SPRING; BRUSH	62F 24

Part Name	Key No.	Part Name	Key No.	Part Name	Key No.
SPRING; COIL	62 124	STUD; INJ. BRKT.	2 56	WASHER	63C 8
SPRING; COIL	62C 43	SWITCH ASM.; MAGNETIC	62B 4	WASHER; CORRUGATED	15 9
SPRING; COMPRESSION	9 56	SWITCH ASM.; MAGNETIC	62 80	WASHER; CRANK, PLULLEY	7 34
SPRING; GOVERNOR	52 75	SWITCH ASM.; MAGNETIC	62C 80	WASHER; CRANK, PLULLEY	7 34 1
SPRING; GOVERNOR	52 75 1	SWITCH ASM.; MAGNETIC	62D 5	WASHER; FELT	62 19
SPRING; PISTON	54B 2	SWITCH ASM.; MAGNETIC	62E 37	WASHER; FELT	62C 19
SPRING; PLUNGER	52 27	SWITCH ASM.; MAGNETIC	62F 41	WASHER; FLYWHEEL FIX.	7 22
SPRING; PUMP, CONT.	18 60	SWITCH; OVER HEAT	12 25	WASHER; GASKET	14 45
SPRING; RETURN	62E 28	SWITCH; OVER HEAT	12 25 2	WASHER; HEAT SHIELD	15 8
SPRING; SHUTTER, RETURN	13 63	SWITCH; PRESSURE, WARNING	19 40	WASHER; IDLE GEAR SHAFT	9 68
-----		-----		-----	
SPRING; SHUTTER, RETURN	13 63 1	SWITCH; PRESSURE, WARNING	19 40 1	WASHER; INSULATE	62D 19
SPRING; TORSION	62E 35	SWITCH; STARTER	19 46	WASHER; INSULATOR	62B 7
SPRING; VALVE, OUTER	9 30	SWIVEL LEVER	52 74	WASHER; INSULATOR	62B 15
SPRING; NOZZLE	58 4	TAPPET	9 38	WASHER; NOZZLE HOLDER	15 7
STARTER ASM. 12V-1.0KW	62F	TAPPET	54 3	WASHER; OIL PAN FIX.	5 24
STARTER ASM.;	62E	TAPPET ASM.	52 21	WASHER; PL.	1 58
STARTER ASM.; FIG. 62	19 1	THERMOMETER UNIT	12 25 1	WASHER; PL.	3 47
STARTER ASM.; FIG. 62B	19 1 3	THERMOMETER UNIT	12 25 3	WASHER; PL.	5 22 1
STARTER ASM.; FIG. 62C	19 1 2	THERMOSTAT;	12 55	WASHER; PL.	6 16
STARTER ASM.; FIG. 62D	19 1 2	THERMOSTAT;	12 55	WASHER; PL.	9 59
-----		-----		-----	
STARTER ASM.; FIG. 62E	19 1 4	THROWER; DUST SEAL	7 39	WASHER; PL.	9 62
STARTER ASM.; FIG. 62F	19 1 2	TUBE; DIST	5 26	WASHER; PL.	12 41
STARTER ASM.; FIG. 62F	19 1 3	TUBE; INSULATOR	63B 13	WASHER; PL.	12 41 1
STARTER ASM.; 12V-1.4KW	62	TUBE; INSULATOR	63B 18	WASHER; PL.	13 70
STARTER ASM.; 12V-1KW	62B	TUBE; INSULATOR	63C 13	WASHER; PL.	13 77
STARTER ASM.; 12V-1KW	62C	TUBE; INSULATE	63C 18	WASHER; PL.	14 36
STARTER ASM.; 12V-1KW	62D	VALVE ASM.; RELIEF VLV.	10 28	WASHER; PL.	19 29
STARTER ASM.	63 6	VALVE ASM.; RELIEF VLV.	10 28 1	WASHER; PL.	19 30
STATOR ASM.	63B 20	VALVE ASM.; SAFETY	10 40	WASHER; PL.	52 60
STATOR ASM.	63C 20	VALVE ASM.; DELIVERY	52 16	WASHER; SPR.	52 10
-----		-----		-----	
STATOR ASM.	63E 5	VALVE; CHECK	54 8	WASHER; SPR.	52 50 1
STATOR KIT	62 130	VALVE; EXH.	9 26	WASHER; SPR.	52 61
STOPPER	62E 27	VALVE; INLET	9 25	WASHER; SPR.	52 66
STOPPER SET	62E 26	VANE; OIL PUMP	6 11	WASHER; SPR.	52 86
STOPPER; PINION	62B 6	WASHER	1 31	WASHER; SPR.	2 48
STOPPER; PINION	62D 12	WASHER	52 9	WASHER; SPR.	3 11
STRAINER ASM.; OIL	6 22	WASHER	52 70 2	WASHER; SPR.	3 17
STRAINER ASM.; OIL	6 22 1	WASHER	52 86 1	WASHER; SPR.	3 27
STUD	12 21	WASHER	52 90	WASHER; SPR.	3 27 2
STUD	13 21	WASHER	52 90 1	WASHER; SPR.	3 27 3
-----		-----		-----	
STUD	13 21 1	WASHER	52 113	WASHER; SPR.	3 37
STUD	13 21 2	WASHER	52 117	WASHER; SPR.	4 8
STUD;	13 3	WASHER	54 17	WASHER; SPR.	5 22
STUD;	52 2	WASHER	62B 8	WASHER; SPR.	6 15
STUD; GEAR CASE	2 37	WASHER	62B 13	WASHER; SPR.	6 26
STUD; HEAD COVER	1 23	WASHER	62B 14	WASHER; SPR.	10 49
STUD; HYDRAULIC, PUMP	3 10	WASHER	62D 17	WASHER; SPR.	10 49 1
STUD; HYDRAULIC	2 56 1	WASHER	62D 18	WASHER; SPR.	11 6
STUD; HYDRAULIC, PUMP	3 10 1	WASHER	62D 26	WASHER; SPR.	12 22
STUD; HYDRAULIC, PUMP	3 10 2	WASHER	63B 8	WASHER; SPR.	12 42

Part Name	Key No.	Part Name	Key No.	Part Name	Key No.
WASHER; SPR.	13 69				
WASHER; SPR.	13 69 1				
WASHER; SPR.	14 33				
WASHER; SPR.	18 58				
WASHER; SPR.	19 27				
WASHER; SPR.	52 50				
WASHER; SPR.	52 50 2				
WASHER; SPR.	52 86				
WASHER; SPR. REAMER	4 11				
WASHER; SPRING	3 27 1				
-----	-----	-----	-----	-----	-----
WASHER; THRUST(A)	62F 6				
WASHER; THRUST(B)	62F 7				
WASHER; TIMING WHEEL	9 9				
YOKE ASM	62E 8				
YOKE ASM.	62 20				
YOKE ASM.	62C 20				
-----	-----	-----	-----	-----	-----
-----	-----	-----	-----	-----	-----
-----	-----	-----	-----	-----	-----

INDEX

NUMERICAL

Part No.	Key No.	Part No.	Key No.	Part No.	Key No.	Part No.	Key No.	Part No.	Key No.
109604-0150	5 37	509030-0370	12 40 3	511110-1771	1 1 2	511322-0541	3 3	512121-0110	7 4
109623-0890	5 38	509030-0370	18 51 1	511110-1772	1 1 2	511327-0120	3 8 1	512121-0120	7 4
109675-0810	15 32	509300-0431	2 56 1	511110-1773	1 1 2	511341-0862	2 20 1	512124-0110	7 4 1
115619-0240	52 3	509300-0451	2 37	511110-1781	1 1	511341-0910	2 20 2	512124-0120	7 4 1
115619-0900	52 41 9	509300-0550	2 37	511110-1783	1 1	511341-0960	2 20	512126-0110	7 4 2
115619-0900	52 42 9	509360-7220	15 42 1	511110-1921	1 1 1	511341-1050	2 20 1	512126-0120	7 4 2
115639-0030	52 31	509360-7230	15 42 2	511110-1923	1 1 1	511341-1940	2 20 3	512211-0210	7 6
115639-0080	52 4	509360-9121	15 35	511129-0050	12 35	511360-3990	5 1 1	512230-0490	7 8 1
115639-0080	52 54 1	509361-0360	5 40	511141-0470	1 21 1	511360-4760	5 1 2	512230-0491	7 8 1
115639-0080	52 99	509361-0600	15 42	511141-0480	1 21	511360-4770	5 1 3	512230-0492	7 8 1
115639-0090	52 81	509361-0741	15 42 1	511150-1170	1 14	511360-5000	5 1 4	512230-0500	7 8
115649-0030	52 54	509400-0250	62B 2	511150-1180	1 14	511361-1120	5 1	512230-0520	7 8
115729-0060	52 11	509400-0250	62D 3	511170-1422	1 29 1	511367-0390	5 10 1	512230-0580	7 8
115729-2360	52 122	509400-0420	62C 81	511170-2551	1 29 2	511367-0392	5 10 1	512235-0080	7 11
115749-0070	52 50 1	509449-0180	3 25 3	511170-2580	1 29	511367-0470	5 10 2	512251-0070	7 9
119389-0040	1 53	509503-0310	5 24	511210-0666	2 1 2	511367-0472	5 10 2	512271-0320	7 13
119389-0050	1 56	509503-0460	62B 15	511210-0667	2 1 2	511367-0511	5 10	512310-1110	7 14
181129-0400	62B 1	509503-0590	9 68	511210-0696	2 1	511369-0850	5 35	512310-1112	7 14
181129-0400	62D 1	509503-0640	63B 8	511210-0697	2 1	511369-0860	5 35	512310-1120	7 14 1
181129-0430	62B 22	509503-0640	63C 8	511210-0956	2 1 1	511510-0330	7 1	512310-1122	7 14 1
182310-0060	19 46	509605-0191	2 11	511210-1540	2 1 1	511540-0330	7 1 1	512310-1280	7 14 2
182410-0081	19 40 1	509605-0191	2 11 1	511210-1542	2 1 1	511560-0330	7 1 2	512310-1282	7 14 2
509000-0181	7 24	509623-0060	10 70	511215-0540	5 27	511711-0230	1 8	512330-1290	7 19
509000-0690	9 8	509623-0190	18 45	511215-0541	5 27	511715-0200	1 7	512330-1291	7 19
509000-0840	3 15	509623-0310	12 34	511215-0611	5 27 1	511721-0130	1 9 1	512330-1442	7 19 3
509000-0840	5 23	509623-0340	3 33	511215-0790	5 27 1	511760-0920	5 18	512330-1443	7 19 3
509000-0840	9 22	509623-0340	3 33 1	511311-0380	2 50 3	511760-1240	5 18 1	512330-1531	7 19 1
509000-0840	12 40	509623-0420	12 59	511311-0491	2 50 1	511760-1243	5 18 1	512330-1532	7 19 1
509000-0840	12 40 5	509623-0730	3 33	511311-0532	3 1	511760-1400	5 18	512330-1541	7 19 2
509000-0840	18 55	509625-0360	2 25	511311-0540	2 50	511771-0501	16 47 1	512330-1542	7 19 2
509000-0940	3 36 1	509625-0790	3 19	511311-0570	2 50 2	511771-1350	16 46	512336-0020	7 22
509000-0970	3 36	509630-0080	10 74	511311-0700	3 1 1	511771-1360	16 47	512371-1740	7 38
509000-1560	2 2	509637-0130	12 57	511311-0741	3 1 3	511771-1470	16 46 1	512371-2150	7 30
509000-1580	12 56	509637-0150	13 62	511311-0760	3 1 2	511777-0320	16 11	512371-2160	7 30 2
509000-1580	12 64 4	509637-0150	13 62 1	511311-0790	2 50 2	511777-0330	16 15 1	512371-2350	7 30 1
509000-1621	9 69	509637-0150	13 73	511312-0230	2 52 1	511777-0440	16 11 1	512371-2390	7 30 1
509000-1770	63B 22	509674-0151	15 25	511312-0250	3 3 2	511777-0450	16 15 3	512379-0090	7 35
509000-2000	5 15 8	509700-2250	15 45	511312-0260	2 52	511777-0590	16 15 2	512511-0721	9 1
509000-2270	2 21	509704-0590	15 43	511312-0280	3 3 1	512111-1600	7 3 1	512511-0762	9 1 1
509000-2270	2 21 1	509707-0041	15 43 1	511312-0290	3 3 3	512111-1690	7 3	512519-0021	9 9
509000-2270	4 7	509707-0360	15 43 2	511312-0300	2 52 2	512111-2310	7 3 1	512521-0181	7 25
509000-2380	63C 19	509740-0150	2 58	511319-0770	18 50 1	512111-2450	7 3	512521-0280	7 25
509000-2390	63C 16	509800-0300	3 32 1	511319-0780	3 38	512114-1600	7 3 1	512522-0221	9 6 1
509000-2400	63C 22	509800-0400	62 13	511319-0790	3 40	512114-1690	7 3	512522-0281	9 6 2
509009-0360	1 22	509800-0400	62C 13	511319-1150	3 6	512114-2310	7 3 1	512523-0110	9 18
509030-0150	3 15 1	509800-0410	62 12	511321-0540	3 2 2	512114-2450	7 3	512523-0200	9 65
509030-0150	18 51	509800-0420	9 67	511321-0590	3 2 1	512116-1600	7 3 1	512524-0380	18 42
509030-0190	12 20 2	509800-0790	62C 12	511321-0600	3 2 3	512116-1690	7 3	512524-0380	52 48
509030-0370	3 36 1	509800-0870	63 20	511321-0830	3 21 2	512116-2310	7 3 1	512524-0400	52 46
509030-0370	9 22 1	509800-0870	63E 26	511322-0351	3 22 1	512116-2450	7 3	512524-0590	18 42 1

Part No.	Key No.	Part No.	Key No.	Part No.	Key No.	Part No.	Key No.	Part No.	Key No.
512524-0590	52 48 1	513610-1390	12 1	514111-0850	13 72 2	515339-0240	58 8	515411-8220	15 25
512525-0111	3 30 1	513610-1392	12 1	514111-1350	13 72 1	515339-0250	58 8	515411-8230	15 30
512525-0112	3 30 1	513610-1393	12 1	514111-1982	13 1 1	515339-0260	58 8	515419-0140	15 37
512529-0110	9 70	513610-1410	12 1 1	514111-1983	13 1 1	515339-0270	58 8	515600-8982	18 5
512531-0080	9 15 1	513610-1412	12 1 1	514111-2180	13 1	515339-0280	58 8	515600-8982	52
512531-0170	9 66	513610-1413	12 1 1	514141-0060	13 20 3	515339-0290	58 8	515601-0122	18 5 1
512531-0191	9 15 2	513610-1531	12 1 2	514141-0630	13 20 1	515339-0300	58 8	515601-0122	52 1
512531-0200	9 66 1	513610-1802	12 1 2	514141-0800	13 20	515339-0310	58 8	515601-0123	52 1
512531-0230	9 66 1	513610-1890	12 1 2	514141-0860	13 20 2	515339-0320	58 8	515601-0124	18 5 1
512533-0100	3 31 1	513610-1891	12 1 2	514141-0861	13 20 2	515339-0330	58 8	515601-0124	52 1
512533-0101	3 31 1	513610-2070	12 1	514210-0490	14 40	515339-0340	58 8	515601-0132	18 5 2
512535-0050	9 20	513612-0130	12 17	514211-0130	14 41	515339-0350	58 8	515601-0132	52 6
512535-0090	9 21	513612-0132	12 17	514211-1110	14 5	515339-0360	58 8	515601-0142	18 5 6
512539-0220	9 70	513612-0140	12 17 1	514212-0110	14 46	515339-0370	58 8	515601-0142	52 5
512551-0200	9 25	513612-0142	12 17 1	514212-0750	14 17	515339-0380	58 8	515601-0152	18 5 5
512551-0201	9 25	513612-0151	12 17 2	514215-0021	14 43	515339-0390	58 8	515601-0152	52 4
512552-0280	9 26	513612-0171	12 17 2	514217-0010	14 44	515339-0400	58 8	515601-0790	18 5 3
512552-0282	9 26	513612-0190	12 17 2	514217-0020	14 47	515339-0410	58 8	515601-0790	52 2
512563-0160	9 32	513612-0191	12 17 2	514217-0100	14 10	515339-0420	58 8	515601-1350	18 5 4
512565-0040	9 35	513612-0250	12 17	514219-0020	14 45	515339-0430	58 8	515601-1350	52 3
512569-0040	1 11	513613-0090	12 12 1	514239-0700	14 20	515339-0440	58 8	515601-1530	52 6
512575-0140	9 40	513619-0982	12 32	514310-2743	13 60	515339-0450	58 8	515601-1531	18 5 2
513100-0940	6 1 1	513641-0300	12 60 2	514319-1000	13 64	515339-0460	58 8	515601-1531	52 6
513100-1280	6 1	513641-0420	12 60 3	514319-3140	13 66	515339-0470	58 8	515601-1540	18 5 6
513113-0260	6 13 1	513642-0470	12 15	514319-3180	13 64 1	515339-0480	58 8	515601-1540	52 5
513140-0060	6 22	513642-0471	12 15	514334-0010	13 66 1	515339-0490	58 8	515601-1550	52 4
513140-0090	6 22 1	513642-0540	12 15 1	515311-0180	15 2	515339-0500	58 8	515601-1551	18 5 5
513160-0030	10 28 1	513642-0770	12 63 2	515311-0220	15 2	515339-0510	58 8	515601-1551	52 4
513200-1380	10 60	513660-2710	12 62 4	515330-0160	15 3	515339-0520	58 8	515601-1601	18 5 8
513200-1582	10 1	513660-2711	12 62 4	515330-0160	58	515339-0530	58 8	515601-1601	52 8
513200-1892	10 1 1	513660-2970	12 62 3	515330-0161	15 3	515339-0540	58 8	515601-1612	52 7
513200-1960	10 1 2	513660-3110	12 62 5	515330-0161	58	515339-0550	58 8	515601-1613	18 5 7
513200-1962	10 1 2	513662-0100	12 62	515332-0040	58 16	515339-0560	58 8	515601-1613	52 7
513200-1965	10 1 2	513662-0110	12 62 1	515339-0070	58 8	515339-0570	58 8	515601-1620	18 5 4
513210-0061	10 6	513671-0400	12 66	515339-0080	58 8	515339-0580	58 8	515601-1620	52 3
513210-0160	10 6 1	513671-0920	12 66 1	515339-0090	58 8	515339-0590	58 8	515601-1622	52 3
513210-0190	10 6 2	513671-1380	12 66 1	515339-0100	58 8	515343-0040	58 4	515601-1623	18 5 4
513210-0192	10 6 2	513674-0630	12 45	515339-0110	58 8	515365-0010	58 20	515601-1623	52 3
513210-0193	10 6 2	513674-0710	12 45 1	515339-0120	58 8	515411-5660	15 30	515601-1980	18 5 3
513211-0110	10 62	513674-0750	12 45 2	515339-0130	58 8	515411-5761	15 15	515601-1980	52 2
513212-0330	10 64	513674-0830	12 45 1	515339-0140	58 8	515411-5771	15 16	515601-1990	18 5
513213-0031	10 65	513674-0840	12 45 2	515339-0150	58 8	515411-5781	15 17	515601-1990	52
513219-0140	10 45	513674-0860	12 45	515339-0160	58 8	515411-7370	15 15 1	515601-2050	18 5 10
513219-0290	10 82	513711-0081	12 51	515339-0170	58 8	515411-7380	15 16 1	515601-2050	52 10
513240-0260	10 2 1	513711-0082	12 51	515339-0180	58 8	515411-7391	15 17 1	515601-2060	18 5 9
513240-0410	10 2	513721-0430	2 35	515339-0190	58 8	515411-8090	15 15 1	515601-2060	52 9
513240-0420	10 2 1	513743-0190	12 34	515339-0200	58 8	515411-8100	15 16 1	515601-2710	18 5 3
513260-0070	10 40	513743-0190	12 34 1	515339-0210	58 8	515411-8101	15 16 1	515601-2710	52 2
513310-1191	11 2	513770-0220	12 55	515339-0220	58 8	515411-8110	15 17 1	515601-4370	18 5 11
513310-1410	11 2 1	513770-0221	12 55	515339-0230	58 8	515411-8120	15 44	515601-4370	52 11

Part No.	Key No.	Part No.	Key No.	Part No.	Key No.	Part No.	Key No.	Part No.	Key No.
515611-0570	52 1	515629-0160	52 41 1	515729-1340	52 83	515759-0200	54 10	581111-0070	62 20
515611-0610	52 1 1	515629-0160	52 42 1	515729-1350	52 83 1	515759-0210	54 13	581111-0110	62C 20
515611-0680	52 1 2	515629-0170	52 41 2	515729-1370	52 83 3	515759-0220	54 21	581112-0210	62B 10
515612-0050	52 44	515629-0170	52 42 2	515729-1420	52 84	515759-0320	54B 5	581112-0240	62D 30
515612-0060	52 5 1	515629-0180	52 41 3	515729-1430	52 87	515759-0330	54B 6	581112-0320	62F 15
515612-0070	52 8 1	515629-0180	52 42 3	515729-1440	52 88	515759-0340	54B 8	581113-0130	62F 28
515612-0130	52 5	515629-0190	52 41 4	515729-1510	52 95	515759-0350	54B 9	581113-0370	62B 16
515612-0140	52 8	515629-0190	52 42 4	515729-1520	52 97	515759-0360	54B 11	581113-0380	62D 20
515619-0230	52 91	515629-0200	52 41 5	515729-1520	52 107	515759-0370	54B 12	581113-0390	62D 14
515619-0240	52 114	515629-0200	52 42 5	515729-1630	52 77 2	515759-0380	54B 13	581113-0400	62D 9
515619-0380	52 41 6	515629-0210	52 41 7	515729-1640	54 16	515761-0020	54 7	581113-0530	62E 31
515619-0380	52 42 6	515629-0210	52 42 7	515729-1650	54 32	515763-0010	54 6	581114-0200	62B 20
515619-0390	52 41 8	515629-0220	52 40	515729-1670	52 94	515781-0040	52 47	581115-0100	62F 19
515619-0390	52 41 10	515629-0350	52 86 1	515729-2020	52 77	515781-0060	52 46 1	581115-0330	62B 25
515619-0390	52 42 8	515629-0360	52 87 1	515729-2030	52 96	515781-0070	52 47 1	581115-0340	62C 30
515619-0470	52 51	515629-0370	52 50 2	515729-2040	52 109	515781-0080	52 47 3	581115-0390	62D 24
515619-0490	52 52	515632-0070	52 15	515729-2040	52 119 1	519380-0192	3 41	581115-0620	62E 13
515619-0610	52 59	515635-0010	52 33	515729-2210	52 77 1	519380-0200	1 50	581116-0200	62 33
515619-0660	52 89	515635-0020	52 34	515729-2300	52 116	519387-0011	3 42	581116-0330	62B 11
515619-0680	52 101	515636-0010	52 32	515729-2320	52 120	519387-0020	3 43	581116-0340	62B 24
515619-0690	52 102	515637-0080	52 30	515729-2330	52 111	519387-0030	1 54	581116-0550	62 130
515619-0700	52 77 3	515639-0030	52 18	515729-2340	52 115	519389-0020	3 44	581117-0070	62 35
515619-0780	52 6	515639-0040	52 28	515729-2350	52 117	519389-0030	1 52	581117-0070	62C 35
515619-0780	52 14	515641-0070	52 16	515729-2360	52 118	519389-0040	1 55	581117-0160	62B 23
515619-0780	52 73	515721-0280	52 92	515729-2370	52 119	519389-0050	3 45	581117-0230	62F 24
515619-0810	52 12	515722-0100	52 85	515750-0060	18 20 1	519389-0060	1 56	581118-0220	62C 33
515619-0820	52 13 1	515723-1190	52 75	515750-0060	54	519711-0721	16 20	581118-0230	62D 23
515619-0840	52 53	515723-1380	52 75 1	515750-0290	54B	519711-0760	16 20 1	581118-0370	62E 39
515619-0860	52 57	515723-1390	52 112	515750-0291	18 20	519711-0770	16 20 3	581119-0180	62D 10
515619-0990	52 20	515725-0510	52 67	515750-0300	18 20 1	519711-0970	16 20 1	581119-0290	62C 83
515619-1010	52 7	515725-0520	52 74	515750-0300	54	519711-0971	16 20 1	581119-0340	62F 17
515619-1020	52 13	515725-0530	52 76 1	515750-0330	18 20 1	519711-0980	16 20	581119-0350	62F 22
515619-1030	52 58	515725-0540	52 78	515750-0330	54	519711-1010	16 20 2	581119-0360	62F 23
515619-1040	52 63	515725-0900	52 76	515751-0030	54 1	519751-0290	18 38	581121-0110	62F 3
515619-1050	52 64	515725-1010	52 67 1	515751-0090	54B 1	519751-0390	18 38 1	581121-0180	62 5
515619-1110	52 7 1	515725-1060	52 67 2	515751-0100	54B 10	519751-0390	52 58 1	581121-0300	62B 9
515619-1120	52 49 1	515725-1080	52 110	515751-0150	52 1 3	523336-0010	18 59	581121-0310	62C 5
515619-1130	52 89 1	515729-0440	52 97 2	515753-0010	54 5	581100-0860	19 1	581121-0340	62D 28
515619-1140	52 97 1	515729-0580	52 93	515753-0020	54 33	581100-0860	62	581122-0180	62B 19
515619-1140	52 107 1	515729-0580	52 93 1	515753-0030	54B 4	581100-1232	19 1 3	581123-0060	62F 26
515619-1150	52 101 1	515729-0980	52 55	515753-0040	54B 7	581100-1232	62B	581123-0100	62 120
515619-1380	52 47 2	515729-0990	52 56	515754-0030	54 3	581100-1650	19 1 2	581123-0110	62 121
515621-0270	52 36	515729-1000	52 100	515754-0040	54B 2	581100-1650	62C	581123-0110	62C 40
515621-0280	52 36 1	515729-1090	52 106	515754-0050	54B 3	581100-1800	19 1 2	581123-0340	62E 21
515621-0310	52 36 3	515729-1140	54 2	515755-0040	54 8	581100-1800	62D	581123-0350	62E 23
515621-0320	52 36 2	515729-1150	54 15	515759-0160	54 18	581100-2050	19 1 2	581124-0030	62 55
515629-0060	52 22	515729-1250	52 68	515759-0160	54 18 1	581100-2050	19 1 3	581124-0060	62C 55
515629-0070	52 23	515729-1290	52 79	515759-0170	54 30	581100-2050	62F	581127-0110	62F 37
515629-0150	52 41	515729-1300	52 80	515759-0180	54 4	581100-2100	19 1 4	581127-0190	62B 3
515629-0150	52 42	515729-1320	52 82	515759-0190	54 9	581100-2100	62E	581127-0220	62D 2

Part No.	Key No.	Part No.	Key No.	Part No.	Key No.	Part No.	Key No.	Part No.	Key No.
581127-0220	62D 16	581151-0410	62B 4	581219-0360	63E 9	581410-0690	19 10 1	900090-1810	63 5
581127-0270	62E 33	581151-0420	62C 80	581221-0520	63B 1	581420-0110	19 20	900090-1810	63E 27
581128-0270	62B 7	581151-0440	62D 5	581221-0540	63 3	581420-0370	19 20	900090-2330	52 38
581128-0280	62B 14	581151-0620	62F 41	581221-0550	63C 1	581420-0410	19 20 1	900090-6670	3 32
581128-0340	62B 13	581151-0670	62E 37	581221-0630	63E 3	582410-0121	19 40	900090-6790	7 36
581129-0090	62B 17	581200-2210	19 2 1	581222-0510	63C 23	582450-0140	12 25	900097-0110	10 50
581129-0170	62D 22	581200-2210	63B	581222-0570	63 75	582450-0180	12 25 1	901045-6320	62E 49
581129-0190	62D 13	581200-3000	19 2 1	581222-0630	63B 23	582450-0200	12 25 2	901045-6320	62F 46
581129-0550	62B 6	581200-3000	63C	581222-0750	63C 23 1	582553-0671	19 45	901045-8500	6 14
581129-0550	62D 12	581200-3040	19 2	581222-0760	63E 19	587810-2050	12 4 1	901045-8750	10 48 2
581129-0580	62F 44	581200-3040	63	581222-0820	63E 19 1	589113-6150	5 26	901045-8750	10 48 4
581129-0640	62E 22	581200-3041	63	581224-0020	63B 4	894110-9300	7 13	901045-8950	13 50 2
581129-0920	62 125	581200-3042	19 2	581224-0020	63C 4	894132-6650	10 39	901050-8500	9 58
581129-0920	62C 44	581200-3042	63	581229-0290	63 19	894136-2490	7 13 1	901055-8350	19 25
581129-0930	62 65	581200-3200	19 2 2	581229-0290	63E 18	894136-2500	7 13 2	901055-8500	9 22 1
581129-0950	62 94	581200-3200	63C	581229-0970	63B 5	894200-7391	7 34 1	901055-8500	12 40 3
581129-0960	62 124	581200-3381	19 2 1	581229-0970	63C 5	894202-4810	12 12	901055-8500	18 51 1
581129-0960	62C 43	581200-3381	63E	581229-0980	63B 6	894205-5611	15 43 1	901055-8550	3 15
581129-0970	62 19	581200-3410	19 2 3	581229-0980	63C 6	894205-9860	12 40 6	901055-8600	5 23
581129-0980	62 113	581200-3410	63E	581229-1010	63B 11	894205-9870	12 40 4	901055-8600	12 56
581129-0990	62 122	581200-3490	19 2 2	581229-1320	63B 2	894205-9870	18 51	901055-8750	3 15 2
581129-0990	62C 41	581200-3490	63E	581229-1370	63B 13	894208-2570	62F 8	901065-8320	5 15 4
581129-1000	62 123	581211-0480	63B 20	581229-1410	63B 7	894208-2870	62F 6	901065-8350	5 15 4
581129-1000	62C 42	581211-0500	63 6	581229-1430	63B 16	894208-2880	62F 7	901065-8350	5 15 5
581129-1170	62B 12	581211-0580	63E 5	581229-1440	63B 18	894208-2890	62F 11	901065-8400	5 15 10
581129-1580	62D 19	581211-0660	63C 20	581229-1480	63B 19	894208-2900	62F 12	901065-8400	9 22 2
581129-1590	62D 18	581213-0390	63B 21	581229-1620	63 31	894208-2910	62F 16	901065-8450	5 15 3
581129-1600	62D 17	581213-0430	63 18	581229-1650	63 21	894208-2950	62F 20	901065-8650	5 15 6
581129-1780	62B 18	581213-0430	63E 17	581229-1650	63E 28	894208-2980	62F 29	901065-8900	5 15 9
581129-1790	62B 21	581213-0450	63C 21	581229-1660	63 11	894208-3050	62F 32	901066-6450	7 42
581129-1800	62B 26	581213-0560	63E 17 1	581229-1660	63E 30	894208-3060	62F 33	901900-6120	3 4
581129-1810	62C 82	581214-0890	63B 12	581229-1670	63C 7	894208-3070	62F 34	901900-6120	3 4 1
581129-1820	62C 94	581214-1010	63B 10	581229-1680	63C 2	894208-3080	62F 35	901900-6140	52 45
581129-1830	62C 85	581214-1040	63 7	581229-1700	63B 15	894211-4390	12 4	901900-6140	52 49
581129-1840	62C 19	581214-1120	63C 10	581229-1700	63C 15	894221-1670	7 13	901900-8200	2 55 1
581129-1850	62C 65	581214-1130	63C 12	581229-1710	63C 18	894228-4360	62E 5	901900-8200	13 74
581129-1920	62D 4	581214-1310	63E 7	581229-1720	63C 13	894228-4370	62E 6	901900-8220	2 55
581129-1960	62D 29	581214-1320	63 8	581229-1820	63 90	894228-4390	62E 10	901900-8220	12 20 3
581129-1990	62D 21	581214-1320	63E 8	581229-1820	63E 22	894228-4480	62E 24	901900-8300	10 48
581129-2000	62D 27	581214-1480	63E 7 1	581229-1830	63 91	894228-4490	62E 25	901900-8300	10 48 1
581129-2010	62D 26	581214-1490	63E 8 1	581229-1830	63E 23	894228-4500	62E 26	901900-8450	10 48 3
581129-2070	62D 31	581215-0380	63 9	581229-2370	63C 11	894242-0590	62E 4	901900-8450	10 48 5
581129-2080	62D 7	581215-0390	63 13	581251-0110	63B 9	894242-0600	62E 9	901900-8450	12 40 2
581129-2090	62D 15	581215-0400	63 15	581251-0130	63C 9	894242-0610	62E 11	901910-6120	5 15 2
581129-2320	62D 6	581215-0400	63E 12	581262-0050	63 16	894242-0620	62E 19	901910-6120	12 64 2
581129-2340	62D 8	581215-0410	63C 17	581262-0050	63E 14	894242-0630	62E 15	901910-6160	3 46
581129-2350	62D 25	581215-0460	63E 10	581270-0040	63 10	894242-0640	62E 16	901910-6160	5 15 1
581129-2630	62E 48	581217-0160	63B 17	581270-0040	63E 13	894242-0650	62E 17	901910-6200	12 64 3
581129-2910	62 85	581218-0310	63C 14	581410-0490	19 10	894242-0710	62E 46	901910-6250	12 64 1
581151-0190	62 80	581219-0270	63B 14	581410-0610	19 10	900090-0660	52 37	901910-6350	12 64

Part No.	Key No.	Part No.	Key No.	Part No.	Key No.	Part No.	Key No.	Part No.	Key No.
901910-8140	14 35	904100-8480	13 3	909150-5080	3 27 1	909661-0050	12 30 2	911175-0110	1 35
901910-8160	5 15	904110-8200	3 10	909150-5080	3 27 2	909662-0120	5 5	911175-0120	1 35
901910-8160	7 41	904110-8200	3 10 1	909150-5080	3 27 3	909664-0010	2 36	911179-0300	1 32
901910-8160	9 12	904110-8200	3 10 2	909150-5080	3 37	909664-0340	1 10	911179-1050	1 31
901910-8180	16 17	904110-8220	2 56	909150-5080	5 22	909664-0340	2 8	911219-1950	2 6
901910-8200	5 23 1	904110-8220	13 21 1	909150-5080	6 15	909715-0540	15 43	911229-0490	2 40
901910-8220	12 43	904110-8250	13 21 2	909150-5080	6 26	909720-0260	10 82	911258-1080	5 29
901910-8220	19 28	904110-8550	3 10 1	909150-5080	10 49	909742-0630	13 63	911312-0340	3 5 2
901910-8250	19 28	904111-0250	13 21 2	909150-5080	10 49 1	909800-6840	2 21	911312-0460	3 5 1
901910-8280	12 58	905820-8350	9 71	909150-5080	12 22	909801-2740	5 15 9	911312-0460	3 48
901910-8300	3 34	905820-8450	9 71	909150-5080	12 42	909802-5141	1 22	911312-8030	3 5
901910-8300	3 34 1	908000-7160	9 7	909150-5080	13 69	909802-6060	7 33	911321-1370	3 2
901910-8300	12 20 1	908010-7400	7 23	909150-5080	18 58	909812-0210	13 65	911321-1480	3 2 4
901910-8320	3 15 3	908030-7430	7 23	909150-5080	19 27	909840-2380	7 12	911321-1790	3 21
901910-8320	3 34	908150-6140	7 37	909150-5080	52 61	909851-8260	5 30	911321-1790	3 21 1
901910-8320	12 43 1	908151-0180	2 28 2	909150-5080	52 86	909857-0530	10 78	911322-0660	3 3
901910-8320	18 51	908151-0200	5 28 1	909150-5100	2 48	909860-5220	1 15	911322-0830	3 22
901910-8450	12 40 2	908151-0220	2 53 1	909150-5100	4 11	909878-0840	6 8	911327-0450	3 8
901911 0200	7 45	908151-0300	2 53	909150-5120	4 8	909878-5320	7 21	911341-6270	4 1
901911 0200	16 27	908151 2220	5 28	909150 5120	52 50	909902-2990	2 13	911581-0570	7 2
901911-0200	16 48	908151-2220	7 17	909160-5080	12 41	909906-1051	11 3	911681-0100	9 11
901911-0220	16 22 2	908160-5120	7 40	909160-5080	12 41 1	909913-5250	15 28 1	911721-1130	1 9
901911-0250	16 50	908161-0280	2 28 1	909160-6060	3 47	909913-8460	15 28	911750-6020	1 30
901911-0300	4 9	908161-0320	2 28	909160-6080	52 60	909913-8490	15 28	912235-0680	7 11 1
901911-0300	16 49	909110-4060	14 12	909160-7080	1 58	909915-1630	15 43 3	912319-0030	7 16
901911-0400	16 22 1	909110-4080	3 25	909164-0080	9 59	909915-5131	5 41	912330-6191	7 19 4
901911-0400	16 50	909110-4080	3 25 1	909164-5080	6 16	909920-5250	10 38	912333-0361	7 20
901931-2250	2 57	909110-4080	3 25 2	909164-5080	9 62	909920-6010	3 3 4	912373-6051	7 30 3
901931-2350	4 9 1	909110-4080	3 25 3	909164-5080	13 70	909920-6090	5 20	912373-6060	7 39
901931-2350	19 42 1	909110-4080	3 25 4	909164-5080	13 77	909920-6510	5 6	912379-0160	7 34
901931-2400	19 42	909110-4080	12 23	909164-5080	14 36	909920-8410	10 45 1	912522-1440	9 6 3
901960-5080	19 29	909110-4080	13 68	909164-7080	5 22 1	909920-8430	1 61	912522-8010	9 6
901960-8250	6 17 1	909110-4080	18 56	909164-7080	19 30	909920-9000	11 4	912523-0800	9 18
901960-8320	13 50	909110-4100	2 47	909180-0190	9 57	909920-9750	10 38 1	912525-8010	3 30
901960-8350	13 50 1	909110-4100	4 10	909201-0560	2 9	909921-2460	18 50	912525-8011	3 30
901970-6160	5 15 1	909110-5080	1 57	909201-3180	2 10	909924-4480	3 19	912531-0241	9 15
901970-8220	10 85	909110-5080	9 61	909201-3450	2 12	909924-4490	2 25	912533-8010	3 31
901970-8250	6 28	909110-5080	19 26	909201-3560	2 9	909940-5820	10 46	912559-0080	9 33
901970-8300	12 20	909111-1080	9 52	909202-0080	1 60	909940-6070	9 56	912561-0370	9 30
901970-8350	19 25	909111-4080	19 43 1	909204-5170	12 30	909941-3000	10 76	912571-8010	9 38
901970-8450	12 40 1	909111-5080	9 52	909204-5170	12 30 1	909942-4190	18 60	912611-3470	9 44
902040-6100	11 5	909120-4120	19 43	909561-2180	5 38	909942-5600	18 60	912611-3490	9 46
902040-6100	13 65 1	909150-5050	3 11	909571-3160	12 31	909942-6000	13 63 1	912616-0230	9 50
902040-6120	6 25	909150-5060	11 6	909571-4120	15 33	909950-1150	7 7	912621-1270	9 53
902040-8250	6 17	909150-5060	13 69 1	909571-4160	4 6	911129-0060	1 3	912621-1271	9 53
902050-6120	14 32	909150-5060	14 33	909572-0120	15 33	911129-0080	2 6 1	912626-0050	9 54
902060-8250	5 15 6	909150-5060	52 10	909600-0820	5 15 7	911129-0810	1 3 1	912628-0930	9 55
903470-6250	14 11	909150-5060	52 66	909612-0210	10 80	911129-0820	1 3 2	913100-6150	6 1
904100-8200	12 21	909150-5080	3 17	909630-0200	13 21	911129-0830	1 3 3	913113-0860	6 13
904100-8250	1 23	909150-5080	3 27	909640-0190	13 76	911173-1370	1 49	913120-6010	6 2

Part No.	Key No.	Part No.	Key No.	Part No.	Key No.	Part No.	Key No.	Part No.	Key No.
913121-0560	6 9	981221-2440	52 24	993490-4120	62F 49				
913123-1030	6 6	981221-2460	52 26	999205-5170	10 39 1				
913125-0470	6 11	981225-0410	52 43	999292-3160	4 5				
913128-0790	6 7	981225-0670	52 39						
913129-0170	6 10	981233-7010	52 30 1						
913141-6041	6 21	981235-0030	52 35						
913143-6030	6 20	981241-3030	52 17						
913160-0680	10 28	981241-3070	52 27						
913231-0750	10 67	981241-4160	52 19						
913240-1100	10 72	981245-0250	52 29						
913240-8041	10 2	981315-0810	52 9						
913263-0110	10 39	981315-1810	52 108 1						
913312-3250	11 1	981325-0810	52 98						
913641-1250	12 60 1	981325-0810	52 108						
913641-6090	12 60	981325-0960	52 70 2						
913642-0760	12 63	981325-0970	52 70 1						
913642-0761	12 63	981325-1120	52 105						
913662-1442	12 62	981325-1730	52 70						
913662-1451	12 62 1	981325-4660	52 53 1						
913671-8080	12 66	981325-5120	52 69						
913671-8090	12 66 2	981325-5120	54 31						
913713-0641	12 50	981351-4030	52 25						
913713-0780	12 50 1	981391-3010	52 90						
914112-6551	13 1 2	981391-3020	52 90 1						
914112-6970	13 72	981391-3020	54 17						
914145-8020	13 75	981391-3110	52 113						
914146-0900	13 46	981393-1020	52 65						
914210-6031	14	981393-2040	52 104						
914213-6130	14 7	981393-3010	52 83 2						
914213-6140	14 6	981393-3020	52 83 4						
914213-6140	14 18	981393-3030	52 83 5						
914215-6040	14 15	981393-3040	52 83 6						
914217-0790	14 21	981393-3050	52 83 7						
914219-1410	14 42	981393-3060	52 90 2						
914234-6020	14 30	981393-3070	52 90 3						
914234-6030	14 31	981393-9010	52 121						
914239-0280	14 8	981393-9070	52 103						
914310-4191	13 60 1	981393-9090	52 107 2						
914319-6260	13 64 2	982115-3470	62B 8						
915315-0260	15 7	982125-1930	62B 5						
915315-0270	15 6	982125-1930	62D 11						
915315-0280	15 8	982215-8390	63B 3						
915315-0740	15 9	982215-8390	63C 3						
915331-0040	58 12	982235-0150	63 80						
915332-0100	58 24	982235-0150	63E 24						
915341-0020	58 1	983151-4320	12 25 3						
915419-0720	15 20	988410-4870	52 51 1						
919732-0750	19 12	989112-9110	2 30						
981215-1150	52 2	989136-4230	12 63 1						
981221-2430	52 21	992040-5100	3 9						

3AE1 - 3AF1 PARTS CATALOG

PARTS CATALOG NO. 5-8871-0114-3

いすゞ自動車株式会社 ISUZU MOTORS LTD.

本 社 東京都品川区南大井 6-22-10
TEL 03-762-1111

Head Office 22-10 Minami-oi 6-chome, Shinagawaku, Tokyo, Japan
Cable Address: ISUZU TOKYO
Phone Tokyo (03)762-1111

編 集 者 横浜市鶴見区下末吉 3-6-1
部品業務部 部品技術室
TEL 045-581-3131(0)

Compiler 6-1 Shimo-sueyoshi 3-chome, Tsurumi-ku Yokohama city

Service Parts Engineering Administration Dept. Parts Div.

PHONE 045-581-3131

S.K. 1984.9 初版 300
1985.1 再版 200

3AF1-3AE1 PARTS CATALOG NO.004

1
1-1

CYL. HEAD & COVER OTHER PARTS(HEAD COVER)

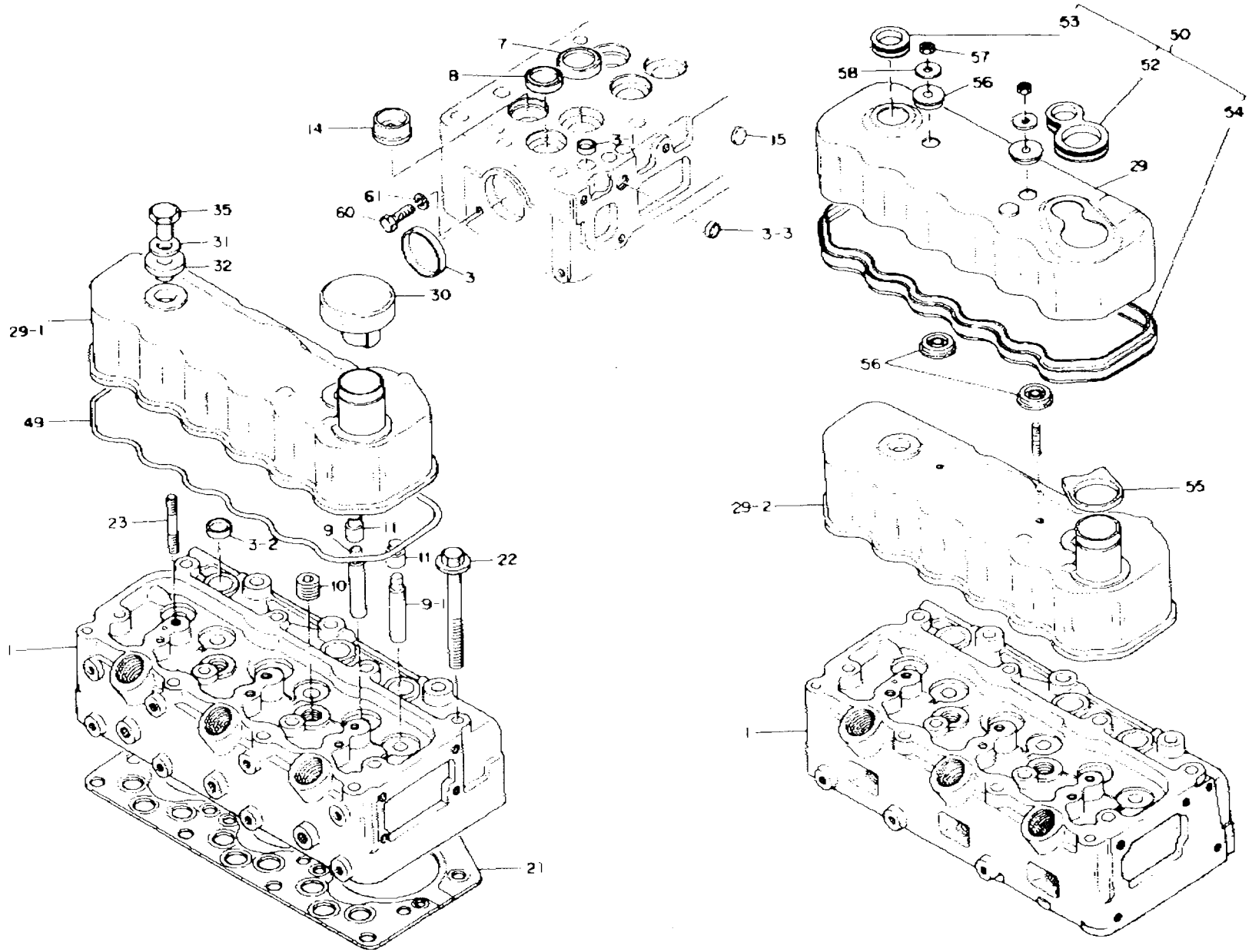

CYL. BLOCK & OTHER PARTS

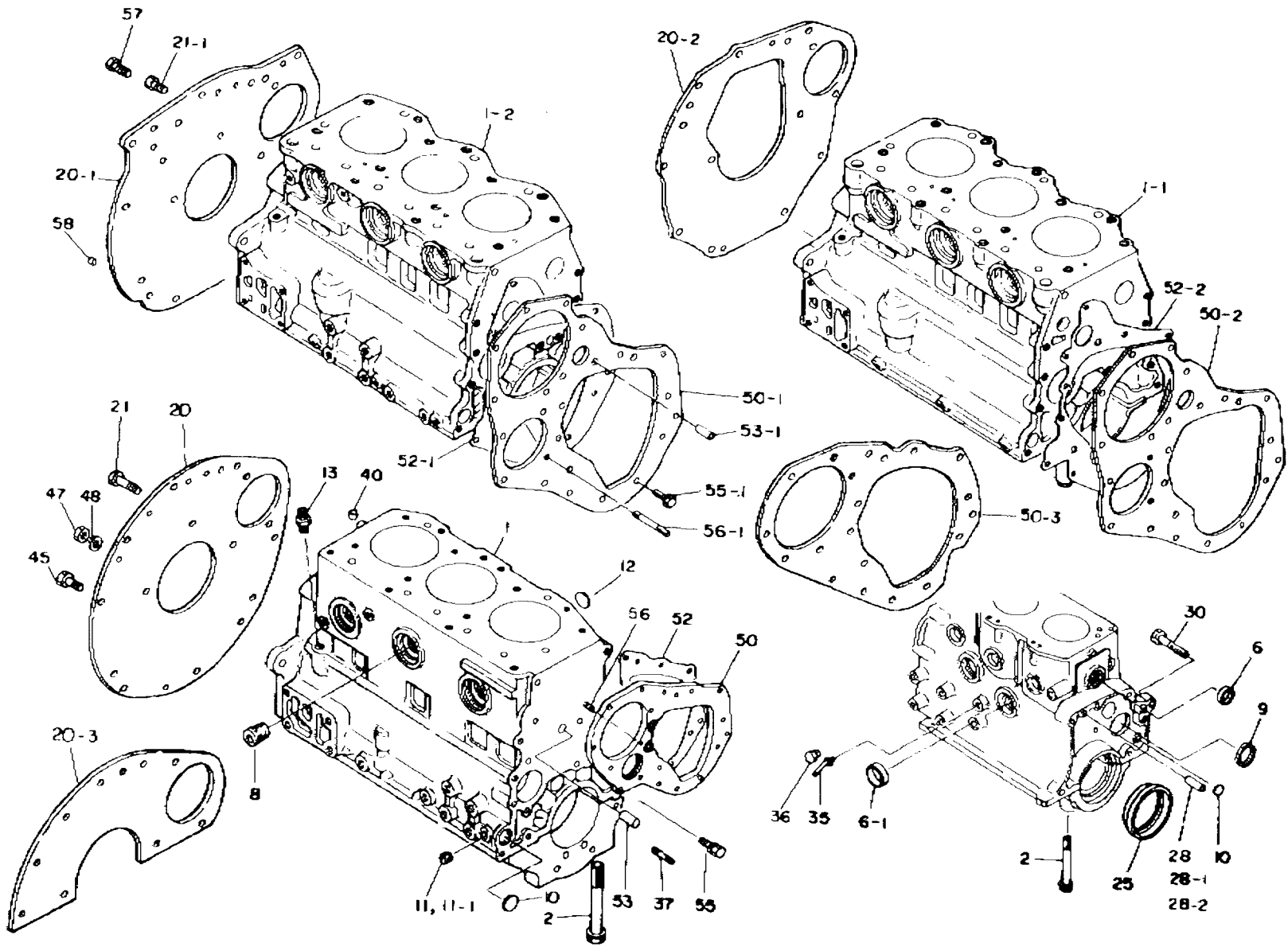

7

7-1

CRANK SHAFT, CRANK BRG., PISTON, CONN. ROD & FLY WHEEL

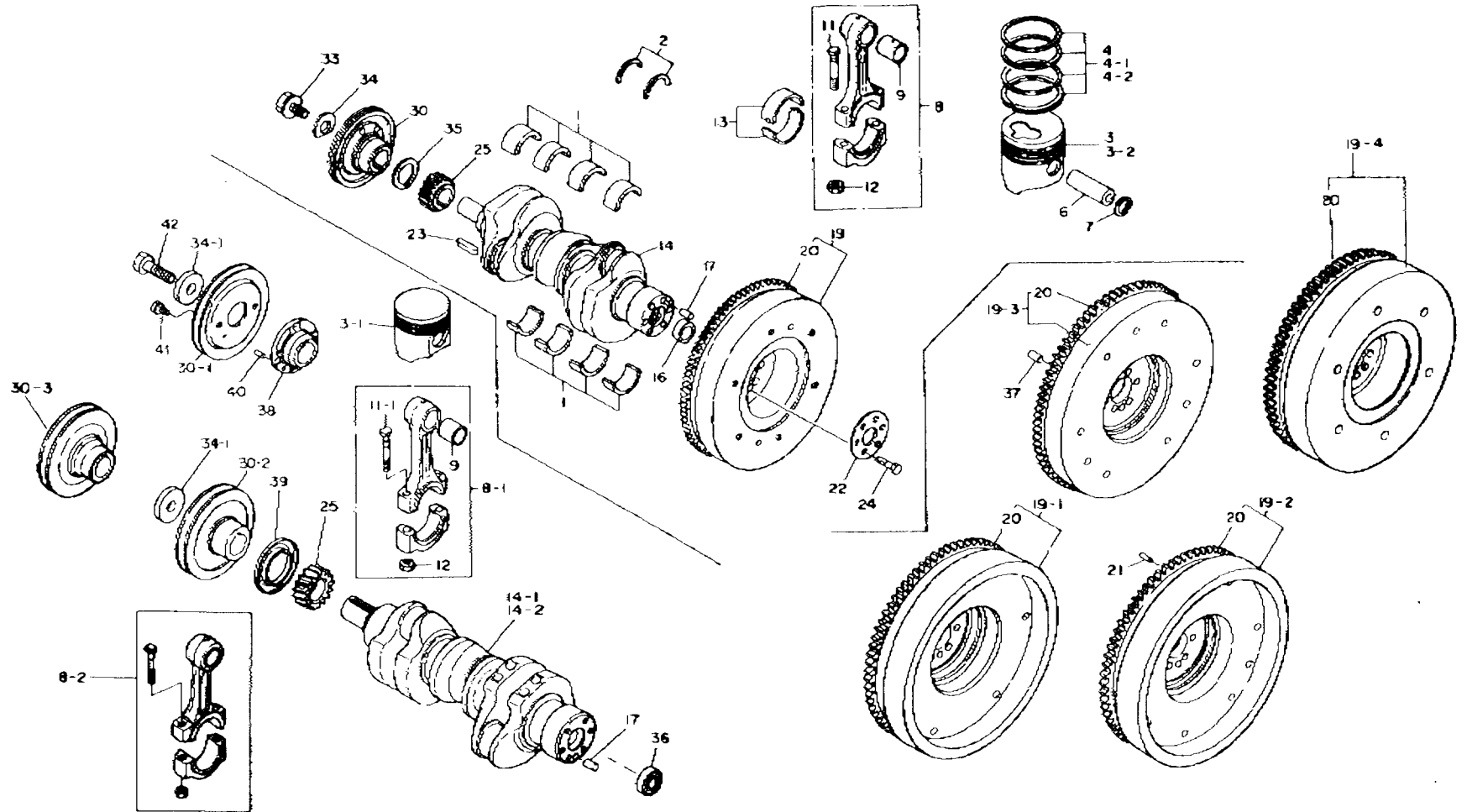

VALVE MECHANISM (CAM SHAFT, IDLE GEAR, ROCKER ARM)

